



WITTENSTEIN

alpha

Products 2011/12

Low backlash planetary gearheads

Servo right-angle gearheads

Mechanical systems



Products 2011/12

Low backlash planetary gearheads
Servo right-angle gearheads
Mechanical systems

© 2011 by WITTENSTEIN alpha GmbH

All technical specifications were correct at the time of going to print. We are continually developing our products and therefore reserve the right to make modifications. This documentation is subject to occasional errors. Please appreciate that legal claims cannot be asserted as a result of incorrect specifications, illustrations or descriptions. The text, photos, technical drawings and any other illustrations printed in this publication are protected property of WITTENSTEIN alpha GmbH.

Further use of this material in printed or electronic format requires express approval from WITTENSTEIN alpha GmbH. Any form of duplication, translation, editing, transfer to microfilm or storage on electronic systems is not permitted without express permission from WITTENSTEIN alpha GmbH.

Contents

Your partner in excellence	6
The WITTENSTEIN alpha product range	18
Gearhead selection overview	20
Low backlash planetary gearheads	22
alpheno®	24
TP+ / TP+ HIGH TORQUE®	28
SP+ / SP+ HIGH SPEED®	66
LP+ / LPB+	114
alphira®	132
Servo right-angle gearheads	142
TK+ / TPK+ / TPK+ HIGH TORQUE®	146
SK+ / SPK+	192
HG+	230
LK+ / LPK+ / LPBK+	242
V-Drive+® / V-Drive economy	270
Mechanical systems	308
alpha Rack & Pinion System	310
alpha IQ	338
Accessories	342
Couplings / Shrink discs	342
Information	368
Quick gearhead selection	370
Gearhead – Detailed design	372
V-Drive® – Detailed design	376
Coupling – Detailed design	378
Glossary	382
Order information	388





Dear Customers,

The desire to innovate and a pioneering spirit led to the formation of alpha getriebebau GmbH more than 25 years ago. While the name of the company has changed, the characteristics that made WITTENSTEIN alpha GmbH the success that it is today remain the same.

The true source of our success lies with you, our customers, who have remained steadfast and loyal over the years. Every day you challenge us to examine and re-evaluate our core competencies and thus contribute to their continuous development.

To stand still is to go backwards. This is particularly true when you look at the ever increasing pace of development for automation dealing with extremely precise actuation and control systems, which can be found not only in traditional mechanical engineering, but also in areas such as the aerospace industry or medical technology. As a globally active company and world market leader of products that fulfill their function reliably and precisely in countless cutting-edge applications, we take our responsibilities very seriously.

Your confidence in our experience and our desire to exceed your expectations in mechatronics have led to over a quarter of a century of continuous and mutual growth and success. We would like to extend our sincere thanks to you for your suggestions, your feedback and for a partnership based on fairness and cooperation.

Looking ahead to the future, we intend to continue using these same strengths and doing exactly what made the founders of the WITTENSTEIN Group and WITTENSTEIN alpha GmbH in particular so successful – to utilize the absolute desire to innovate in order to create future trends. We are well positioned to meet this challenge and are working on some of the most important issues affecting mankind today such as health, climate, energy, water and electric mobility.

For us, resource efficiency isn't just a catchy slogan. It is and has always been a cornerstone of the products that we develop for you, our customers, and you can be assured that it will remain so in the future.

Dieter Derr

Thomas Bayer

Your WITTENSTEIN alpha GmbH Management Team

Our guiding principle – the belief that our systems and products make life easier for our customers and their businesses more successful and efficient. We are continually setting standards and applying advanced technology to give our customers a competitive edge on the market.



WITTENSTEIN

Specialized fields united in one company.

WITTENSTEIN AG is active in seven innovative fields of business:

Servo gearheads, servo drive systems, medical technology, miniature servo units, innovative tothing technology, powerful actuator systems and intelligent electronic solutions. Each company in the WITTENSTEIN Group strives to make advances in their respective field and develop specialized solutions to perfection. The companies that use the WITTENSTEIN name are committed to paving the way for greater freedom of innovation in the future.

The **group**



WITTENSTEIN

alpha

Drives, controls and positional

accuracy are areas that require maximum precision. Products manufactured by WITTENSTEIN alpha GmbH are setting benchmarks worldwide in the fields of mechanical engineering and drive technology. From low backlash planetary gearheads, servo right-angle gearheads and complete drive units to the comprehensive cymex® engineering software package and expert technical consultation: WITTENSTEIN alpha GmbH has redefined the meaning of precision, an essential benchmark and the most important attribute of our products and services.

Value based

Understanding partners.
Communicating processes.
Achieving objectives.

Our systems and products are aimed at making your life easier for a more successful business.





WITTENSTEIN electronics GmbH develops, manufactures and distributes **electronics and software components** for drive technology. Products and services designed for complex mechatronic systems are capable of working under extreme ambient conditions and characterized by their outstanding reliability.



Intelligence fascinates, inspires and adds that extra dimension. Innovative medical technology manufactured by WITTENSTEIN intens GmbH, which **focuses mainly on intelligent implants**, achieves all of the above. FITBONE® is currently the only fully implantable intramedullary nail for bone extension that can be controlled and adjusted via electromechanical traction. Intelligence is crucial to every step of the development process, right up to the end product.



Integration plays a critical role here and is a decisive factor in increasing power density and dynamics. WITTENSTEIN motion control GmbH develops **functional mechatronic systems** from the WITTENSTEIN Group's strong base of core products. These electromechanical systems prove their worth through such key characteristics as control, precision, dynamics, reliability and durability.



Those who subscribe to individuality are forever confronted with new challenges. Whether in the design, manufacture, research or testing phase – when developing innovative gearing technology, WITTENSTEIN bastian GmbH always considers the unique requirements of the different application areas. This is how **individual solutions for motor racing, aerospace and robotics applications** are produced. WITTENSTEIN bastian GmbH redefines the concept of individuality on a daily basis: because the company is open to innovation and has the courage to explore unknown territory.



Dynamics that accelerate progress. Outstanding power and dynamics, minimal weight and maximum reliability characterize the servo motors from WITTENSTEIN cyber motor GmbH. Customized motors from WITTENSTEIN guarantee increased productivity and higher endurance. From intense research and development into special materials, WITTENSTEIN motors are highly capable under extreme conditions such as high vacuum, radioactive, extreme temperature changes.



Maximum effect, minimum weight – the efficiency of each component plays a vital role in the aerospace industry. The powerful electromechanical actuator systems manufactured by WITTENSTEIN aerospace & simulation GmbH represent both high quality and unique compactness. These highly efficient systems are used **in the new Airbus A380, prototypes of the Phoenix space plane and both military and commercial simulators**. Efficiency has adopted a unique meaning: Maximum performance combined with outstanding freedom of innovation.

More than 1400 employees at more than 60 locations. Always there where you need us. Our vision of a successful future together.

WITTENSTEIN worldwide



Argentina · Australia · Austria · Belgium · Brazil
Canada · China · Croatia · Czech Republic
Denmark · Egypt · Finland · France · Germany
Greece · Hungary · India · Israel · Italy · Japan
Korea Republic · Luxembourg · Malaysia · Mexico
Norway · Poland · Portugal · Puerto Rico · Romania
Russia · Singapore · South Africa · Spain · Sweden
Switzerland · Taiwan · Thailand · The Netherlands
Turkey · United Kingdom · United States of America

Network

Five continents.
Three oceans.
More than six billion people.

The WITTENSTEIN group is active in more than 40 countries. An international network with unlimited communication and interaction.



High performance

Journey to the center of the Earth. Voyage of discovery in space. The hunt for the Formula 1 record. WITTENSTEIN drive technology is predominantly used in applications with special requirements. In the most diverse branches of industry. At locations near and far. Under the most extreme conditions. WITTENSTEIN is setting benchmarks worldwide. With outstanding performance and individual solutions.



Photo Phoenix: EADS Astrium

WITTENSTEIN – Products that know no limits. High precision drive systems for diverse branches of industry: Drive technology · Electronics · Machine tools · Manufacturing systems · Robotics, automation, handling · Textile, printing and paper machines · Laser, glass and wood processing machines · Food and packaging machines Pneumatics · Semiconductor · Linear technology ·

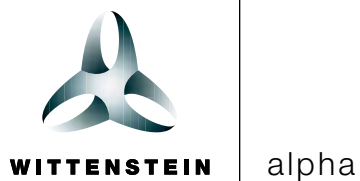

Photo Phoenix: EADS Astrium

Aerospace · Extreme ambient conditions (such as high temperatures, ultra-high vacuums) · Crude oil exploration · Medical technology · Pharmaceutical · Motor racing · Automotive and tire · Optical media · Vehicle technology · Defense technology

For applications requiring compactness, power and precision.

When developing products for wood processing technology, printing technology or robotics, automation and handling technology, we always strive to fulfill demanding requirements and think beyond our limits. With new ideas and innovative systems that give us fresh impetus to promote forward thinking and develop revolutionary concepts.



Business to business

Different needs.
Individual strategies.
Fascinating results.

We understand what counts
in your business and use this
knowledge to develop compatible
solutions that increase efficiency.

WITTENSTEIN alpha – Your partner in excellence



Machine tools and manufacturing systems

Maximum precision, process stability and productivity thanks to durable mechanical system solutions virtually free of backlash and torsion used in feed-, swivel and auxiliary axles.



Food and packaging machines

A range of gearheads designed for all types of axis used in packaging technology – including washdown models – for maximum operating efficiency, machine flexibility and cycle speeds.



Wood processing machines

Mechanical systems such as gearheads with pinion/rack, on-site consultation and a comprehensive knowledge of engineering form an impressive package that guarantees a high-quality end product with maximum efficiency.



Printing and paper machines

Innovative gearhead products that offer high constant speeds, seamless synchronization and permanent precision – the perfect solution for high-quality printing processes and other continuous applications. Available as an option: Integrated sensors for monitoring web tension and similar parameters.



Robotics, automation and handling technology

A wide range of servo gearheads and mechanical drive systems, from low-cost to high-end products for all types of robot and auxiliary axles such as drive axles and tool manipulators.

© MAKA



Customer service – Our excellence through service.

Customer service in WITTENSTEIN stands for **quicker, more reliable and more capable service to customers.** „WITTENSTEIN is committed to being a world class global partner.“ This critical aspect of our corporate philosophy underlies our knowledge of service.

speedline® saves time

– Your gearhead ready for delivery in only 24 hours

Would you like to be more flexible, implement your ideas more quickly and be able to make snap decisions? Then speedline® is the right service for you. We will assemble a standard series SP+, TP+ and LP+ within 24 or 48 hours ex works at attractive conditions – customized to fulfill your individual requirements.

Like all WITTENSTEIN alpha products, you can rely on speedline® to carry out a 100% quality control check on all orders placed. A reliable logistics concept guarantees a prompt delivery to your doorstep.

Your gearhead will be ready within 24 or 48 hours ex works.



24h hotline/Service Center

Technical support from experienced professionals available when you need it.

speedline® team

You need your gear reducer in the next 24 to 48 hours?

Contact your local sales office.

Please see the back cover for contact information.

Web service –

Online access:

You can now access all the relevant information directly online via the web service. For example:

- CAD files in different formats
- installation videos
- operating instructions
- motor installation visuals

Service made to measure

We believe that a made-to-measure service should always include the following:

- Repairs/overhauls
- Spare part deliveries
- On-site deployment
- Condition inspections

We also offer the following services:

- Material and microscopic analyses
- Oil analyses
- Vibration measurement
- Synchronization measurement
- Advice on sealing technology and tribology

cymex Statistics

All statistics relating to experiences made in the field have been documented over the years. cymex Statistics now enables you to evaluate these statistics with a view to developing quality assurance measures for the future.

This knowledge can also be used for:

- lifecycle cost analyses
- MTTF (mean time to first failure)
- reliability calculations
- preventative maintenance measures
- verification of gearhead designs

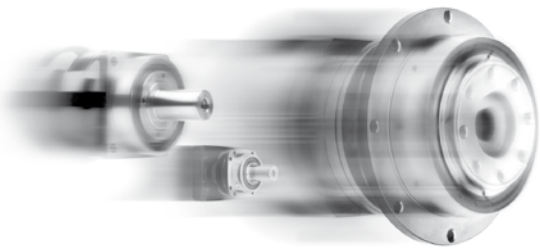

cymex® 3 – Software for drive technology

cymex® enables the simple dimensioning and design of complete drive trains (application + motor + gearhead). Standard predefined applications make precise calculations so much easier.

Consideration for all major influencing factors and specific customer parameters guarantee the perfect design for your drive system.

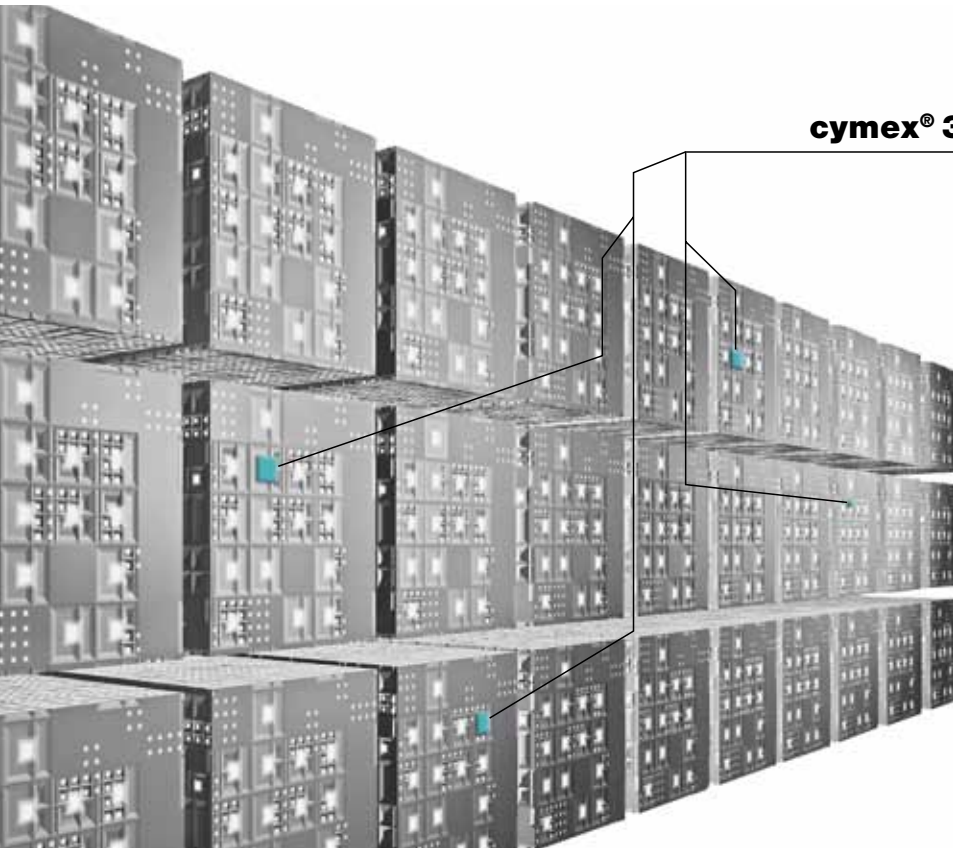

cymex® 3 fast – simple – reliable

cyber motion explorer

Beyond the limits of the catalog

cymex® 3 provides access to a wealth of defined values not available in our product catalogs. The software incorporates decades of WITTENSTEIN AG design experience, extending your design options and achieving a 40% increase in gearhead utilization.

The benefits for you:

- greater accuracy during the design process
- maximum power output
- uncovering hidden potential
- possible use of smaller gearheads to reduce costs

If you're looking for the perfect drive system, benefit from the vast experience of cymex®. Users ranging from experienced to novice rely on this simple software to design gearboxes with unparalleled speed and accuracy.

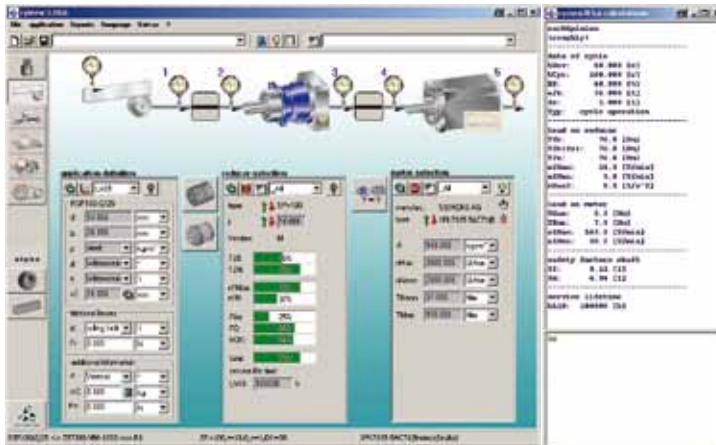

Established features

- Standard predefined applications
- cymex® profiler for creating simple or complex motion and load profiles
- Functions for importing motion profiles from SAM, Excel, ASCII
- Application data and technical data documented in Microsoft Word
- Offline CAD generator: 3D gearhead files including all attached components compatible with the selected motor
- Database containing all current WITTENSTEIN alpha products
- Largest global database with more than 7000 motors offered by all current manufacturers

Seminars

Our WITTENSTEIN academy offers customers and prospective buyers the opportunity to attend seminars on drive technology or training courses on cymex® design software. The content of the training is fully adaptable to fulfill your specific requirements.



cymex® profiler

CAD generator

Motor load

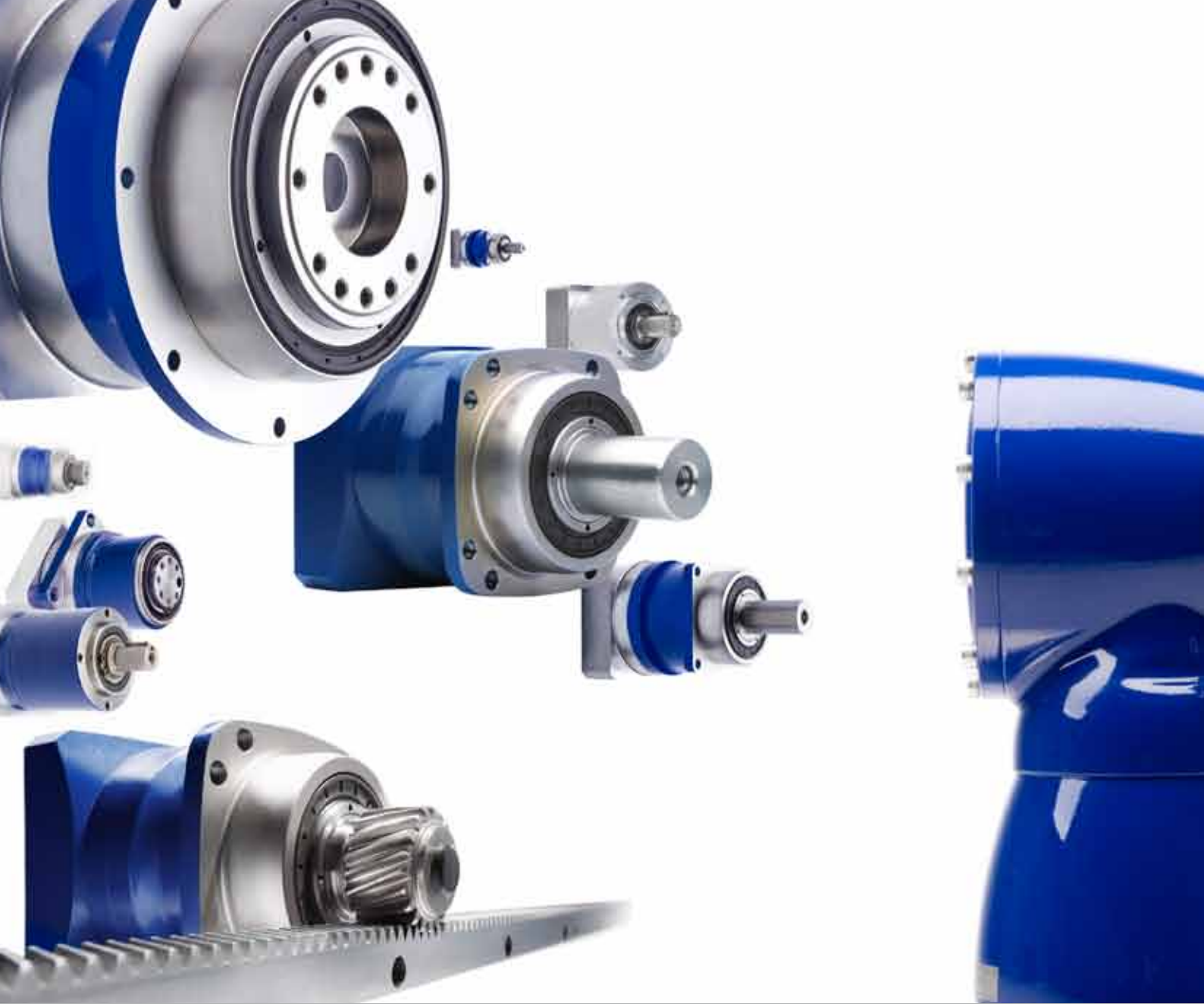

The modular **system**

An unbeatable team.
Drive systems by WITTENSTEIN alpha.

A flexible, variable system consisting of several innovative components: State-of-the-art servo motor and servo gearhead technology, linear systems as well as racks and pinions that achieve unrivalled precision. Unique calculations and simulations allow you to maximize system efficiency.

1+1=1

Drive systems by WITTENSTEIN alpha incorporate different innovations, are designed in line with the modular principle and offer a host of advantages as a result. Maximized speeds and improved positioning accuracy increase productivity and the quality of the product. Effective integration for easier assembly and use.



WITTENSTEIN alpha **products**

Low backlash planetary gearheads

alpheno®
TP+
SP+
LP+/LPB+
alphira®







Servo right-angle gearheads

TK+/TPK+
SK+/SPK+
HG+
LK+/LPK+/LPBK+
V-Drive®





Mechanical systems

alpha Rack and pinion systems
alpha IQ – Intelligent gearheads
Couplings
Belt pulleys
Additional mechanical drive elements

Gearhead selection overview

		Low backlash planetary gearheads							
									
Products		alpheno®	TP+ TP+ HIGH TORQUE®	SP+ SP+ HIGH SPEED®	LP+ LPB+	alphira®			
Catalog page		24	26	64	112	124			
Ratio	min. i =		4	22	3	3	3	3	4
	max. i =		100	220	100	100	100	10	100
Output type									
Smooth output shaft				•	•	•			
Grooved output shaft				•	•	•		•	
Output shaft with involute toothing				•	•				
Shaft mounted <small>Mounted via shrink disc</small>				•	•				
Output flange		•	•				•		
Torsional backlash									
≤ 1 arcmin		•	•	•					
≤ 2 arcmin		•		•	•				
≤ 4 arcmin		•	•	•	•				
≤ 6 arcmin				•	•				
≤ 10 arcmin					•	•	•		
≤ 15 arcmin						•	•		
≤ 20 arcmin								•	
≤ 25 arcmin								•	
Drive type									
Motor attachment version		•	•	•	•	•	•	•	
Drive shaft		•		•					
Optional									
With belt pulley							•		
With pinion and rack		•	•	•	•	•		•	
With coupling		•		•	•	•		•	
Washdown <small>Please contact WITTENSTEIN alpha</small>		•	•	•	•				
Food-grade grease <small>Please contact WITTENSTEIN alpha</small>		•	•	•	•	•	•	•	

Your individual solution – Please contact us

		Servo right-angle gearheads										
												
Products		TK+	TPK+	SK+	SPK+	HG+	LK+	LPK+	LPBK+	VDT+	VDH+ VDHe	VDS+ VDS _e
Catalog page		138		182		220	232			254		
Ratio	min. i =	3	12	3	12	3	1	3	3	4	4	4
	max. i =	100	10000	100	10000	100	1	100	10	40	40	40
Output type												
Smooth output shaft				•	•			•				•
Smooth output shaft, backside		•	•	•	•	•						
Grooved output shaft				•	•		•	•				•
Grooved output shaft, backside		•	•	•	•	•						
Output shaft with involute toothing				•	•							•
Output flange			•						•	•		
Hollow shaft interface, Mounted via shrink disc						•				•	•	
Hollow shaft interface, backside, Mounted via shrink disc		•	•	•	•	•					•	
Hollow shaft flange		•								•		
Shaft mounted Mounted via shrink disc					•							
Closed cover, backside		•	•	•	•	•						
Torsional backlash												
≤ 2 arcmin			•		•							
≤ 4 arcmin		•	•	•	•	•				•	•	•
≤ 5 arcmin		•	•	•	•	•						
≤ 15 arcmin							•	•	•			
Drive type												
Motor attachment version		•	•	•	•	•	•	•	•	•	•	•
Optional												
With pinion and rack		•	•	•	•		•	•		•		•
With coupling		•	•	•	•		•	•		•		•
Shrink disc					•	•					•	
Washdown Please contact WITTENSTEIN alpha		•	•	•	•	•				•	•	•
Food-grade grease Please contact WITTENSTEIN alpha		•	•	•	•	•	•	•	•	•	•	•

alpheno°



TP°



SP°



LP°

LPB°



alphira°



TK°

TPK°



SK°

SPK°



HG°



LK°/LPK°

LPBK°



V-Drive°



Rack and Pinion



alpha IQ



Couplings



Low backlash planetary gearheads by WITTENSTEIN alpha are sure to win over the hearts and minds of engineers and designers who place emphasis on efficiency, productivity and process stability.

alpheno®

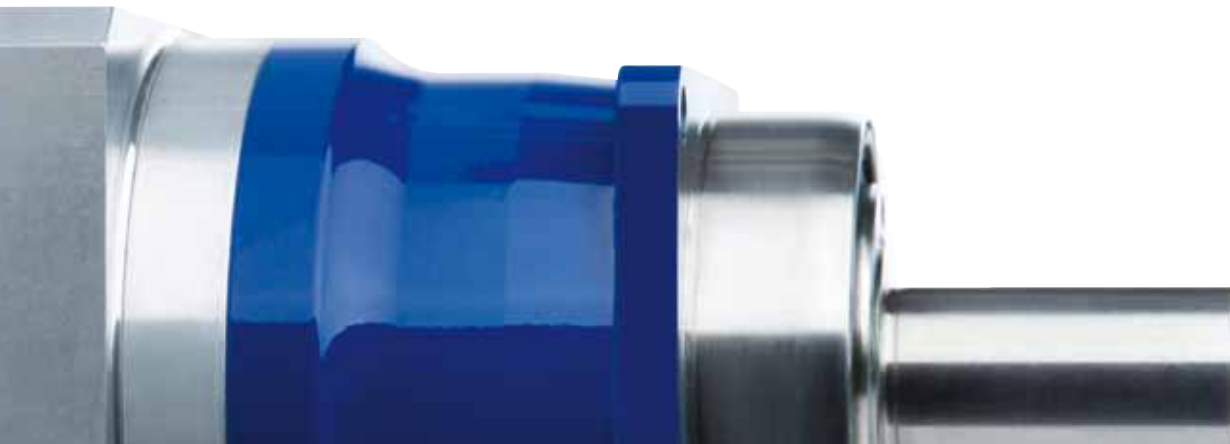

Low backlash planetary gearheads **Maximum power density**

And the torques?

Although the previous series achieved outstanding results, we managed to increase the torques by up to 40%.

Raising the limits – Typical of WITTENSTEIN alpha!

Versatile installation

In whatever position you install your + gearhead, the gearhead always contains the same quantity of oil.

The gearheads are so flexible, you can install them vertically, horizontally or with the output facing upwards or downwards.

High End
TP⁺

SP⁺

Economy
LP⁺

alphira[®]

Simple motor installation

Safe, faultless motor installation is possible in a single working step. The WITTENSTEIN alpha-patented motor attachment is also available with integrated thermal length compensation as an option.

Superior running thanks to the helical teeth

The SP⁺ and TP⁺ gearheads “whisper”. Compared to the classic straight-toothed SP and TP, helical-toothed ⁺ gearheads are 6 dB(A) quieter during operation. And what a difference 64 instead of 70 decibels makes to added value. You will hardly notice the vibrations made by gearheads from the ⁺ series because they run so smoothly.

Maximum positioning accuracy

SP and TP represented compact precision. Now the SP⁺ and TP⁺ represent maximum compact precision because we have managed to further reduce the torsional play compared with the previous series to less than one angular minute to enable you to significantly increase the positioning accuracy in your application.

World-class lifespan

The seal rings on the ⁺ gearhead series were specially developed and the material and geometry are both optimized to ensure an extremely long lifespan!

alpheno®

Perfection in a new dimension



alpheno®

Specifications \ Version	alpheno®		
	+	++	+++
Positioning accuracy			██████████
Rigidity		██████████	
Smooth-running		██████████	
Speed capacity			██████████
Power density		██████████	
Max. axial/radial forces		██████████	

al [pha] + pheno [menal] = alpheno[®]

alpheno[®]



Perfect is not yet perfect enough

The performance capability of the planetary gear reducer reaches a new dimension with alpheno[®]. While others are still dealing with precision and operating noise, WITTENSTEIN alpha is once again a step ahead. alpheno[®] has already been used in highly challenging applications where the individual

requirements exceed the performance capabilities of the standard product range for several years. In comparison to the SP+, it was possible to increase the power density by up to 140% with alpheno[®] – exceeding all current standards in the market.



Quality & reliability

We define quality as a philosophy to live by. A universal QM system with the latest measuring and testing methods ensures quality. We guarantee quality and reliability of your alpheno[®] with 100% final inspection.



Incomparably powerful



WITTENSTEIN alpha defines a new standard

The alpheno® gear output interface facilitates a higher power transmission when compared to the industry standard which limits the transmitting torques of the gearhead. alpheno® transcends these limitations.



The technical advancement of alpheno® and its increased power can be directly utilized for your applications with the new design of the gear output.

alpheno® convinces with highest power density

We offer you more performance in less space for the most compact drive requirements. This will allow your machine to perform better if specific system solutions are required.

Power density of the industry standard and alpheno®

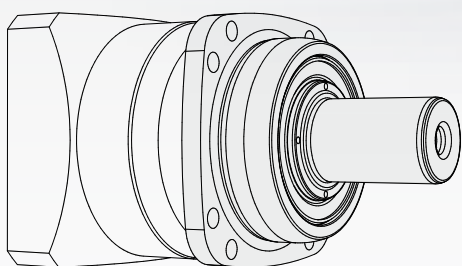
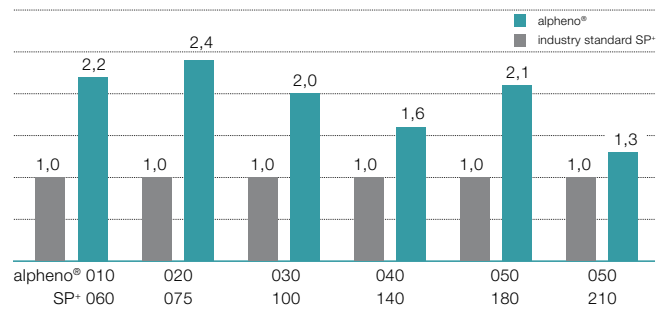

Smooth shaft

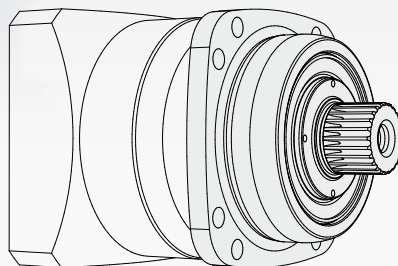

Involute

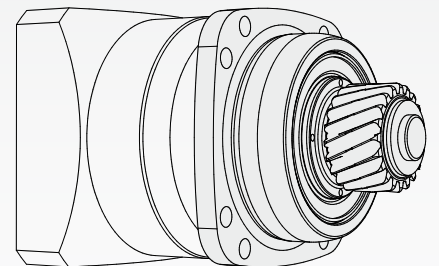

Incl. pinion

Performance data

Looking for a solution that is tailored to your needs? We will collaborate with you to develop your customized solution and ensure the ideal design of your drive.

Torsional backlash [arcmin]	< 1
Ratio [-]	3 - 100
Max. acceleration torque [Nm]	2800
alpha peak torque [Nm]	3360
Max. input speed [min ⁻¹]	6000
Efficiency [%]	97

alpheno® in comparison to the industry standard

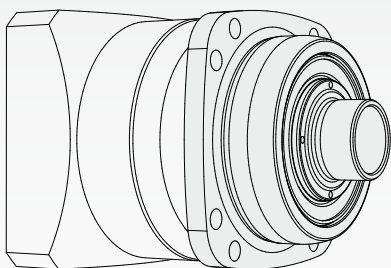
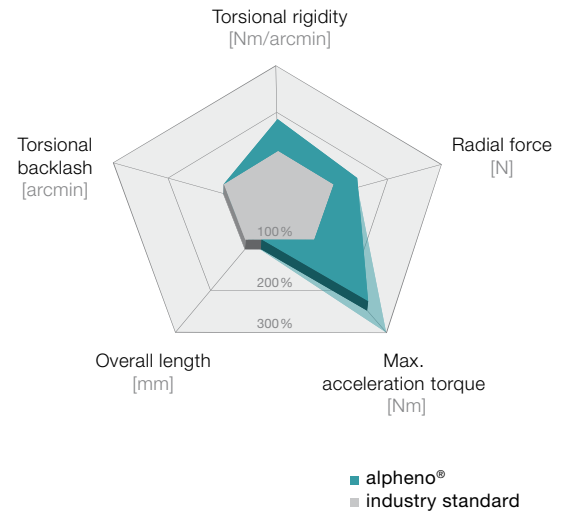

Slip-on shaft

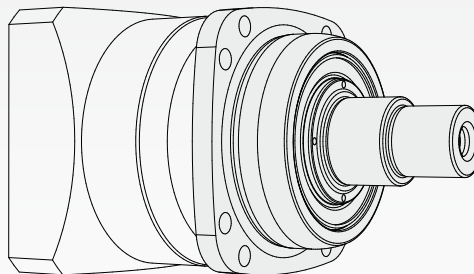

Customer-specific

Options

Like the SP+ shaft gearhead, alpheno® is also available in a HIGH SPEED® version and with a slip-on shaft at the gear output. A variant with optimized mass inertia guarantees a maximum level of energy efficiency. In combination with the WITTENSTEIN alpha rack-and-pinion portfolio, alpheno® represents an unbeatable drive bearing arrangement in the field of linear motion.

TP+ – The new generation

Top performer among compact planetary gearheads with drive flange

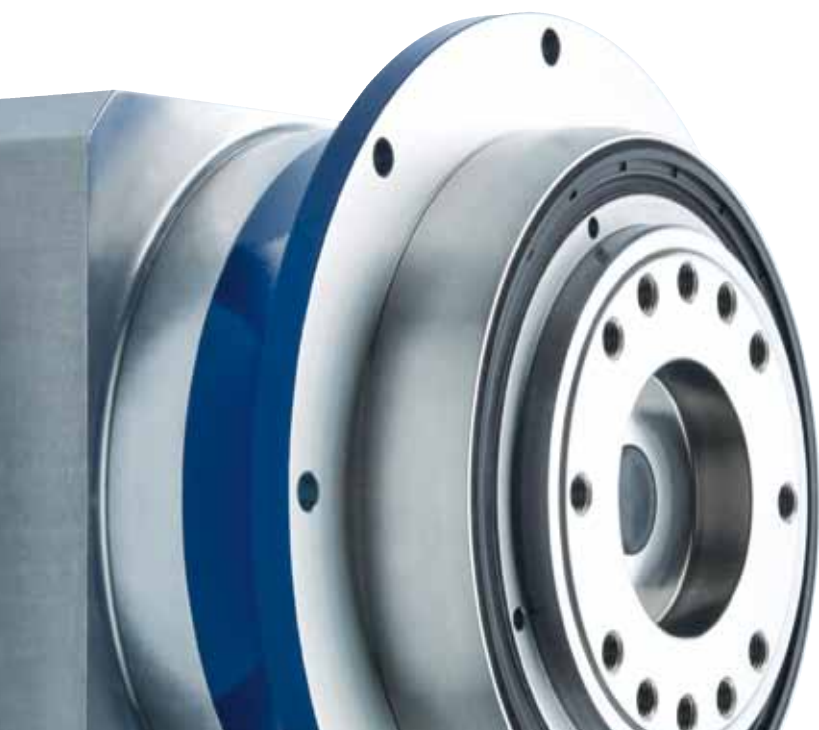

MF version

Designed for:

- Highly dynamic applications
- Greater positioning accuracy
- Space-saving designs

MA version (HIGH TORQUE)

Designed for:

- Maximum power density
- Maximum positioning accuracy
- High torsional rigidity
- Demanding safety requirements

TP+

Specifications \ Version	TP+ MF/MA		
	+	++	+++
Positioning accuracy		MF	MA
Rigidity		MF	MA
Smooth-running		MF/MA	
Speed capacity		MF/MA	
Power density		MF	MA
Max. axial/radial forces		MF/MA	

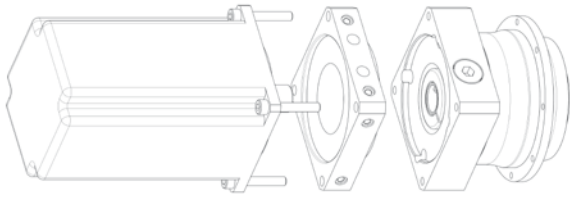

Intermediate flange for cooling system



For Delta robot applications



with sensors

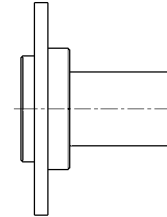

Shaft output



Coupling: BCT



See our website and our separate flyer for more information about our washdown solutions



Sensor flange torqXis



Rack / Pinion

Options

- With sensors (see page 338)
- Washdown version
- Food-grade grease 
- For Delta robot applications
- Version with optimized mass moment of inertia

Accessories

- Rack / Pinion (see page 310)
- Coupling: BCT (see page 342)
- Shaft output
- Intermediate flange for cooling system
- Sensor flange torqXis



Also available as a motor/gearhead unit

TP+ 004 MF 1-stage

				1-stage				
Ratio ^{a)}		<i>i</i>		4	5	7	10	
cymex®-optimized acceleration torque (please contact us regarding the design)	T_{2Bcym}	Nm		60	62	60	–	
		in.lb		531	549	531	–	
Max. acceleration torque (max. 1000 cycles per hour)	T_{2B}	Nm		55	55	55	35	
		in.lb		487	487	487	310	
Nominal output torque (with n_n)	T_{2N}	Nm		28	28	28	18	
		in.lb		248	248	248	159	
Emergency stop torque (permitted 1000 times during the service life of the gearhead)	T_{2Not}	Nm		100	100	100	100	
		in.lb		885	885	885	885	
Nominal input speed (with T_{2N} and 20 °C ambient temperature ^{b)})	n_{1N}	rpm		3300	3300	4000	4000	
Max. input speed	n_{1Max}	rpm		6000	6000	6000	6000	
Mean no load running torque (with $n_1=3000$ rpm and 20 °C gearhead temperature ^{c)})	T_{012}	Nm		0.95	0.80	0.60	0.45	
		in.lb		8.41	7.08	5.31	3.98	
Max. torsional backlash	j_t	arcmin		Standard ≤ 4 / Reduced ≤ 2				
Torsional rigidity ^{c)}	C_{121}	Nm/ arcmin		12	12	11	8	
		in.lb/ arcmin		106	106	97	71	
Tilting rigidity	C_{2K}	Nm/ arcmin		–				
		in.lb/ arcmin		–				
Max. axial force ^{d)}	F_{2AMax}	N		1630				
		lb _f		367				
Max. tilting moment	M_{2KMax}	Nm		110				
		in.lb		974				
Efficiency at full load	η	%		97				
Service life (For calculation, see the Chapter "Information")	L_h	h		> 20000				
Weight incl. standard adapter plate	m	kg		1.4				
		lb _m		3.1				
Operating noise (with $i=10$ and $n_1=3000$ rpm no load)	L_{PA}	dB(A)		≤ 58				
Max. permitted housing temperature		°C		+90				
		F		194				
Ambient temperature		°C		-15 to +40				
		F		5 to 104				
Lubrication				Lubricated for life				
Paint				Blue RAL 5002				
Direction of rotation				Motor and gearhead same direction				
Protection class				IP 65				
Moment of inertia (relates to the drive)	B	11	J_1	kgcm ²	0.17	0.14	0.11	0.09
				10 ⁻³ in.lb.s ²	0.15	0.12	0.10	0.08
Clamping hub diameter [mm]	C	14	J_1	kgcm ²	0.25	0.21	0.18	0.17
				10 ⁻³ in.lb.s ²	0.22	0.19	0.16	0.15
	E	19	J_1	kgcm ²	0.57	0.54	0.51	0.49
				10 ⁻³ in.lb.s ²	0.50	0.47	0.45	0.43

Reduced mass moments of inertia available on request.

^{a)} Other ratios available on request

^{b)} For higher ambient temperatures, please reduce input speed

^{c)} Valid for clamping hub diameter of 14 mm

^{d)} Refers to center of the output shaft or flange

up to 11⁴⁾(B)
clamping hub
diameter

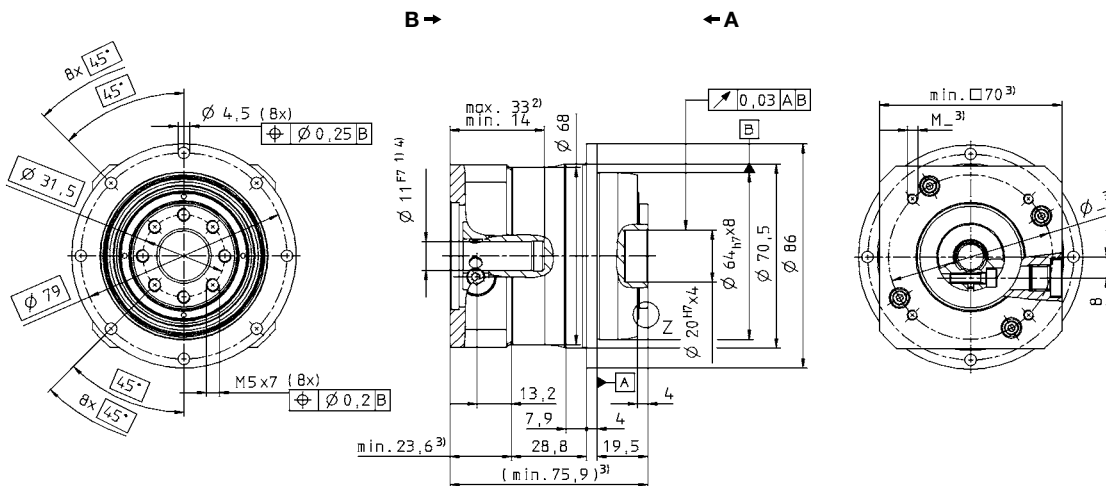

up to 14⁴⁾(C)
clamping hub
diameter

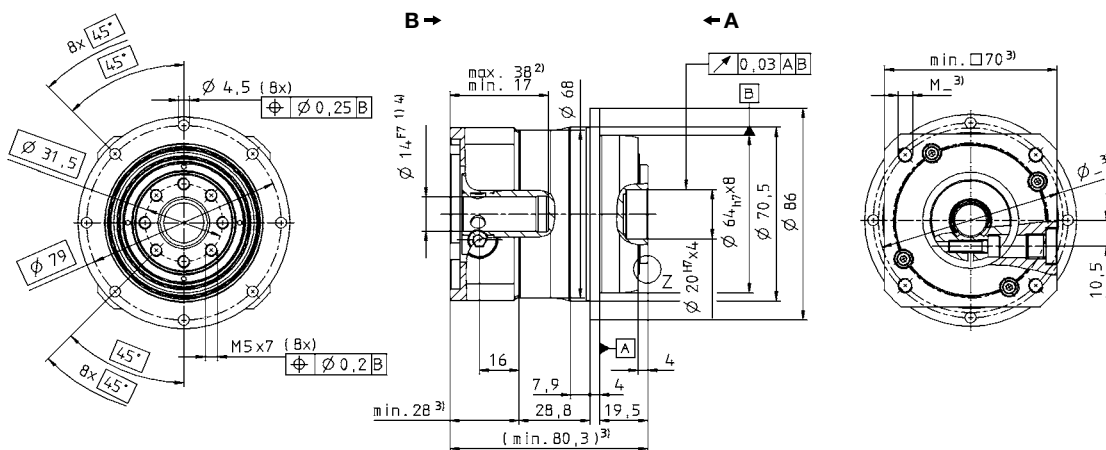

up to 19⁴⁾(E)
clamping hub
diameter

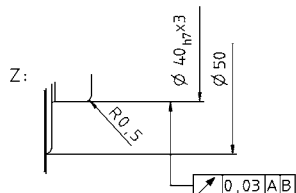
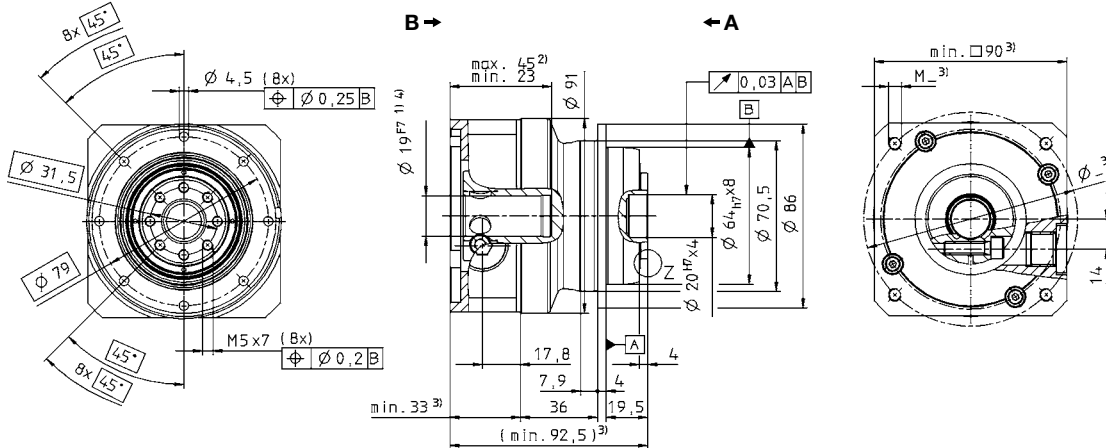

Non-tolerated dimensions ± 1 mm

- 1) Check motor shaft fit.
- 2) Min./Max. permissible motor shaft length. Longer motor shafts are adaptable, please contact us.
- 3) The dimensions depend on the motor.
- 4) Smaller motor shaft diameter is compensated by a bushing with a minimum thickness of 1 mm.

Motor mounting according to operating manual

TP*



Motor shaft diameter [mm]

TP+ 004 MF 2-stage

			2-stage														
Ratio ^{a)}	<i>i</i>		16	20	21	25	28	31	35	40	50	61	70	91	100		
cymex®-optimized acceleration torque (please contact us regarding the design)	T_{2Bcym}	Nm	60	60	–	62	60	–	62	62	62	–	60	–	–		
		in.lb	531	531	–	549	531	–	549	549	549	–	531	–	–		
Max. acceleration torque (max. 1000 cycles per hour)	T_{2B}	Nm	55	55	40	55	55	40	55	55	55	45	55	32	35		
		in.lb	487	487	354	487	487	354	487	487	487	398	487	283	310		
Nominal output torque (with n_n)	T_{2N}	Nm	40	40	30	40	40	30	40	40	40	30	40	15	18		
		in.lb	354	354	266	354	354	266	354	354	354	266	354	133	159		
Emergency stop torque (permitted 1000 times during the service life of the gearhead)	T_{2Nst}	Nm	100	100	100	100	100	100	100	100	100	100	100	100	100		
		in.lb	885	885	885	885	885	885	885	885	885	885	885	885	885		
Nominal input speed (with T_{2N} and 20 °C ambient temperature ^{b)})	n_{1N}	rpm	4000	4000	4000	4000	4000	4000	4000	4000	4800	5500	5500	5500	5500		
Max. input speed	n_{1Max}	rpm	6000	6000	6000	6000	6000	6000	6000	6000	6000	6000	6000	6000	6000		
Mean no load running torque (with $n_n=3000$ rpm and 20 °C gearhead temperature ^{c)})	T_{012}	Nm	0.55	0.45	0.45	0.45	0.35	0.35	0.30	0.25	0.25	0.20	0.20	0.20	0.20		
		in.lb	4.87	3.98	3.98	3.98	3.10	3.10	2.66	2.21	2.21	1.77	1.77	1.77	1.77		
Max. torsional backlash	j_t	arcmin	Standard ≤ 4 / Reduced ≤ 2														
Torsional rigidity ^{c)}	C_{121}	Nm/arcmin	12	12	10	12	12	9	12	11	12	9	11	7	8		
		in.lb/arcmin	106	106	89	106	106	80	106	97	106	80	97	62	71		
Tilting rigidity	C_{2K}	Nm/arcmin	–														
		in.lb/arcmin	–														
Max. axial force ^{d)}	F_{2AMax}	N	1630														
		lb _f	367														
Max. tilting moment	M_{2KMMax}	Nm	110														
		in.lb	974														
Efficiency at full load	η	%	94														
Service life (For calculation, see the Chapter "Information")	L_h	h	> 20000														
Weight incl. standard adapter plate	m	kg	1.5														
		lb _m	3.3														
Operating noise (with $i=100$ and $n_n=3000$ rpm no load)	L_{PA}	dB(A)	≤ 58														
Max. permitted housing temperature		°C	+90														
		F	194														
Ambient temperature		°C	-15 to +40														
		F	5 to 104														
Lubrication			Lubricated for life														
Paint			Blue RAL 5002														
Direction of rotation			Motor and gearhead same direction														
Protection class			IP 65														
Moment of inertia (relates to the drive) Clamping hub diameter [mm]	B	11	J_1	kgcm ²	0.078	0.070	0.074	0.068	0.062	0.072	0.061	0.051	0.057	0.058	0.056	0.057	0.056
				10 ⁻³ in.lb.s ²	0.069	0.062	0.066	0.060	0.054	0.064	0.054	0.051	0.050	0.051	0.050	0.051	0.050
	C	14	J_1	kgcm ²	0.17	0.17	0.17	0.16	0.16	0.17	0.16	0.15	0.15	0.15	0.15	0.15	0.15
				10 ⁻³ in.lb.s ²	0.15	0.15	0.15	0.14	0.14	0.15	0.14	0.14	0.13	0.13	0.13	0.13	0.13

Reduced mass moments of inertia available on request.

^{a)} Other ratios available on request

^{b)} For higher ambient temperatures, please reduce input speed

^{c)} Valid for clamping hub diameter of 11 mm

^{d)} Refers to center of the output shaft or flange

View A

View B

Motor shaft diameter [mm]

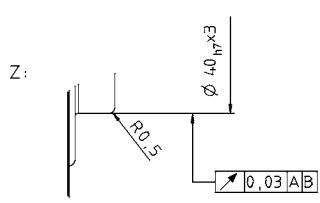
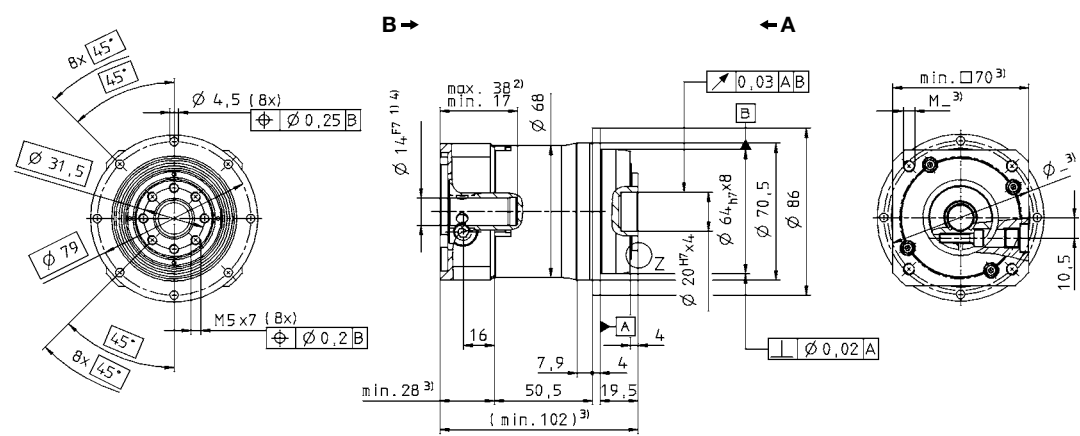
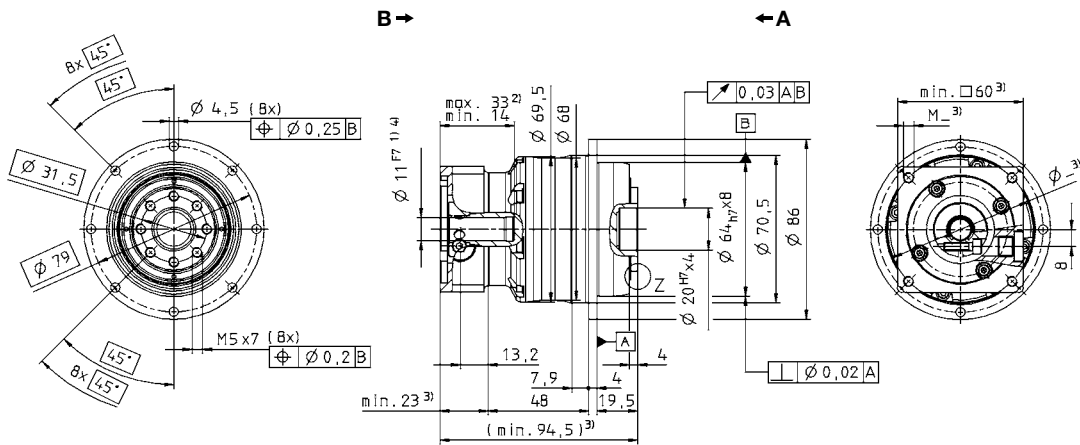
up to 11⁴⁾(B)
clamping hub
diameterup to 14⁴⁾(C)
clamping hub
diameterNon-tolerated dimensions ± 1 mm

- 1) Check motor shaft fit.
- 2) Min./Max. permissible motor shaft length. Longer motor shafts are adaptable, please contact us.
- 3) The dimensions depend on the motor.
- 4) Smaller motor shaft diameter is compensated by a bushing with a minimum thickness of 1 mm.

Motor mounting according to operating manual

TP*



TP+ 010 MF 1-stage

				1-stage				
Ratio ^{a)}	<i>i</i>		4	5	7	10		
cymex®-optimized acceleration torque (please contact us regarding the design)	T_{2Bcym}	Nm	150	162	162	-		
		in.lb	1328	1434	1434	-		
Max. acceleration torque (max. 1000 cycles per hour)	T_{2B}	Nm	143	143	143	105		
		in.lb	1266	1266	1266	929		
Nominal output torque (with n_n)	T_{2N}	Nm	75	75	75	60		
		in.lb	664	664	664	531		
Emergency stop torque (permitted 1000 times during the service life of the gearhead)	T_{2Not}	Nm	250	250	250	250		
		in.lb	2213	2213	2213	2213		
Nominal input speed (with T_{2N} and 20 °C ambient temperature ^{b)})	n_{1N}	rpm	2600	2900	3100	3100		
Max. input speed	n_{1Max}	rpm	6000	6000	6000	6000		
Mean no load running torque (with $n_n=3000$ rpm and 20 °C gearhead temperature ^{c)})	T_{012}	Nm	1.6	1.3	1.0	0.7		
		in.lb	14.2	11.5	8.85	6.20		
Max. torsional backlash	j_t	arcmin	Standard ≤ 3 / Reduced ≤ 1					
Torsional rigidity ^{c)}	C_{I21}	Nm/ arcmin	32	33	30	23		
		in.lb/ arcmin	283	292	266	204		
Tilting rigidity	C_{2K}	Nm/ arcmin	225					
		in.lb/ arcmin	1991					
Max. axial force ^{d)}	F_{2AMax}	N	2150					
		lb _f	484					
Max. tilting moment	M_{2KMax}	Nm	270					
		in.lb	2390					
Efficiency at full load	η	%	97					
Service life (For calculation, see the Chapter "Information")	L_h	h	> 20000					
Weight incl. standard adapter plate	m	kg	3.8					
		lb _m	8.4					
Operating noise (with $i=10$ and $n_n=3000$ rpm no load)	L_{PA}	dB(A)	≤ 59					
Max. permitted housing temperature		°C	+90					
		F	194					
Ambient temperature		°C	-15 to +40					
		F	5 to 104					
Lubrication			Lubricated for life					
Paint			Blue RAL 5002					
Direction of rotation			Motor and gearhead same direction					
Protection class			IP 65					
Moment of inertia (relates to the drive)	C	14	J_1	kgcm ²	0.78	0.62	0.48	0.40
				10 ⁻³ in.lb.s ²	0.69	0.55	0.42	0.35
Clamping hub diameter [mm]	E	19	J_1	kgcm ²	0.95	0.79	0.64	0.57
				10 ⁻³ in.lb.s ²	0.84	0.70	0.57	0.50
	G	24	J_1	kgcm ²	2.32	2.16	2.02	1.94
				10 ⁻³ in.lb.s ²	2.05	1.91	1.78	1.72

Reduced mass moments of inertia available on request.

^{a)} Other ratios available on request

^{b)} For higher ambient temperatures, please reduce input speed

^{c)} Valid for clamping hub diameter of 19 mm

^{d)} Refers to center of the output shaft or flange

View A

View B

up to 14⁴⁾(C)
clamping hub diameter

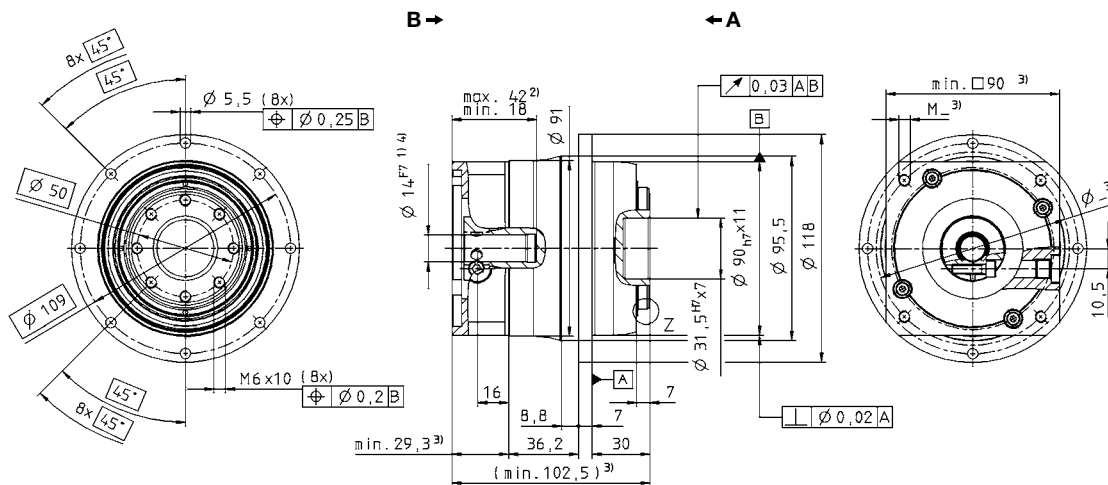

up to 19⁴⁾(E)
clamping hub diameter

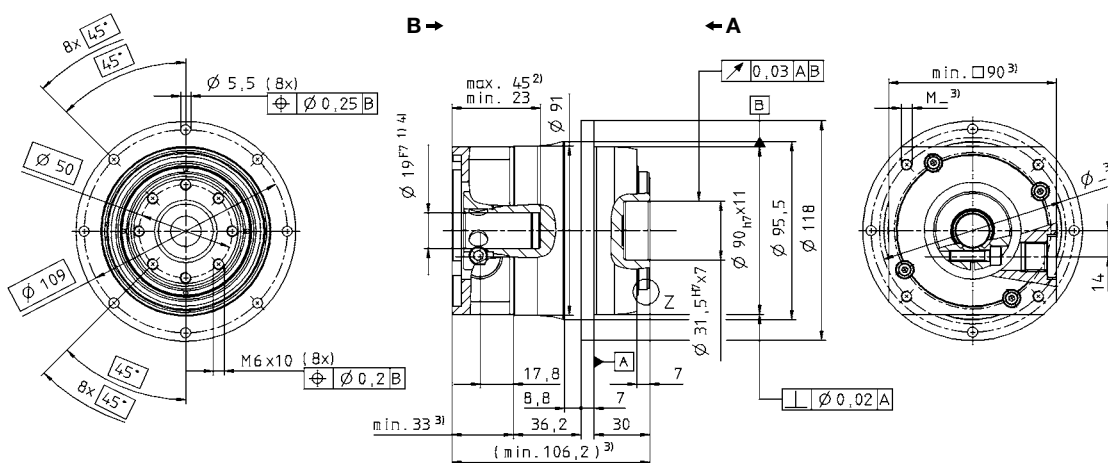

up to 24⁴⁾(G)
clamping hub diameter

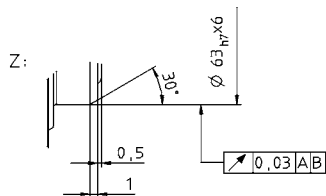
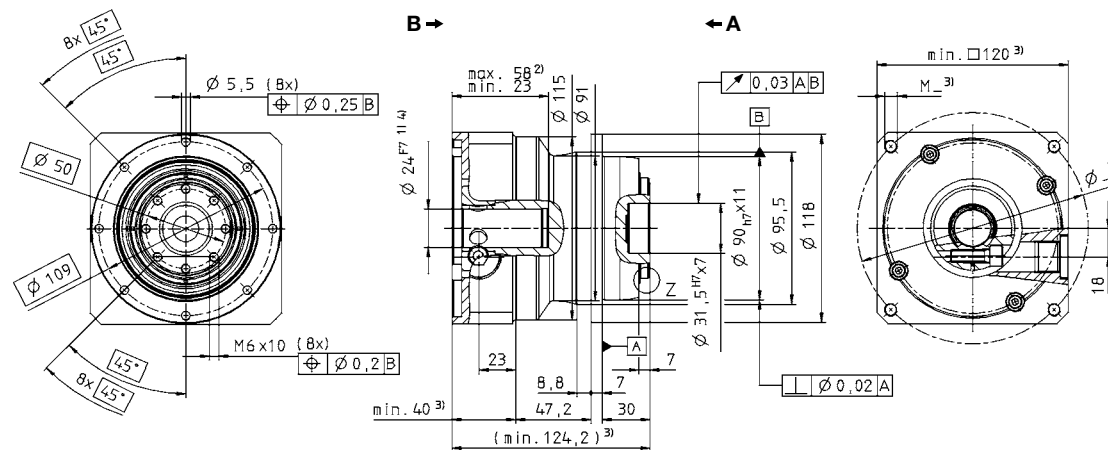

Non-tolerated dimensions ± 1 mm

- 1) Check motor shaft fit.
- 2) Min./Max. permissible motor shaft length. Longer motor shafts are adaptable, please contact us.
- 3) The dimensions depend on the motor.
- 4) Smaller motor shaft diameter is compensated by a bushing with a minimum thickness of 1 mm.

Motor mounting according to operating manual

TP



TP+ 010 MF 2-stage

		2-stage															
Ratio ^{a)}	<i>i</i>		16	20	21	25	28	31	35	40	50	61	70	91	100		
cymex®-optimized acceleration torque (please contact us regarding the design)	T_{2Bcym}	Nm	162	162	–	162	162	–	162	–	162	–	162	–	–		
		in.lb	1434	1434	–	1434	1434	–	1434	–	1434	–	1434	–	–		
Max. acceleration torque (max. 1000 cycles per hour)	T_{2B}	Nm	143	143	100	143	143	110	143	140	143	110	143	80	105		
		in.lb	1266	1266	885	1266	1266	974	1266	1239	1266	974	1266	708	929		
Nominal output torque (with n_{2N})	T_{2N}	Nm	90	90	80	90	90	70	90	80	90	70	90	35	60		
		in.lb	797	797	708	797	797	620	797	708	797	620	797	310	531		
Emergency stop torque (permitted 1000 times during the service life of the gearhead)	T_{2Nst}	Nm	250	250	250	250	250	250	250	250	250	250	250	250	250		
		in.lb	2213	2213	2213	2213	2213	2213	2213	2213	2213	2213	2213	2213	2213		
Nominal input speed (with T_{2N} and 20 °C ambient temperature ^{b)})	n_{1N}	rpm	3500	3500	3500	3500	3500	3500	3500	3500	3800	4500	4500	4500	4500		
Max. input speed	n_{1Max}	rpm	6000	6000	6000	6000	6000	6000	6000	6000	6000	6000	6000	6000	6000		
Mean no load running torque (with $n_1=3000$ rpm and 20 °C gearhead temperature ^{c)})	T_{012}	Nm	0.90	0.75	0.70	0.65	0.55	0.50	0.50	0.40	0.35	0.35	0.35	0.30	0.30		
		in.lb	7.97	6.64	6.20	5.75	4.87	4.43	4.43	3.54	3.10	3.10	3.10	2.66	2.66		
Max. torsional backlash	j_t	arcmin	Standard ≤ 3 / Reduced ≤ 1														
Torsional rigidity ^{c)}	C_{I21}	Nm/arcmin	32	32	26	32	31	24	32	30	30	24	28	21	22		
		in.lb/arcmin	283	283	230	283	274	212	283	266	266	212	248	186	195		
Tilting rigidity	C_{2K}	Nm/arcmin	225														
		in.lb/arcmin	1991														
Max. axial force ^{d)}	F_{2AMax}	N	2150														
		lb _f	484														
Max. tilting moment	M_{2KMax}	Nm	270														
		in.lb	2390														
Efficiency at full load	η	%	94														
Service life (For calculation, see the Chapter "Information")	L_h	h	> 20000														
Weight incl. standard adapter plate	m	kg	3.6														
		lb _m	8.0														
Operating noise (with $i=100$ and $n_1=3000$ rpm no load)	L_{PA}	dB(A)	≤ 59														
Max. permitted housing temperature		°C	+90														
		F	194														
Ambient temperature		°C	-15 to +40														
		F	5 to 104														
Lubrication			Lubricated for life														
Paint			Blue RAL 5002														
Direction of rotation			Motor and gearhead same direction														
Protection class			IP 65														
Moment of inertia (relates to the drive)	B	11	J_1	kgcm ²	0.17	0.14	0.15	0.13	0.11	0.13	0.10	0.09	0.09	0.09	0.09	0.09	
				10 ⁻³ in.lb.s ²	0.15	0.12	0.13	0.12	0.10	0.12	0.09	0.08	0.08	0.08	0.08	0.08	0.08
Clamping hub diameter [mm]	C	14	J_1	kgcm ²	0.24	0.21	0.22	0.20	0.18	0.21	0.18	0.17	0.17	0.17	0.16	0.16	0.16
				10 ⁻³ in.lb.s ²	0.21	0.19	0.19	0.19	0.16	0.18	0.16	0.15	0.15	0.15	0.15	0.14	0.15
	E	19	J_1	kgcm ²	0.56	0.53	0.55	0.53	0.51	0.53	0.50	0.49	0.49	0.49	0.49	0.49	
				10 ⁻³ in.lb.s ²	0.50	0.47	0.49	0.47	0.45	0.47	0.44	0.43	0.43	0.43	0.43	0.43	0.43

Reduced mass moments of inertia available on request.

^{a)} Other ratios available on request

^{b)} For higher ambient temperatures, please reduce input speed

^{c)} Valid for clamping hub diameter of 14 mm

^{d)} Refers to center of the output shaft or flange

View A

View B

up to 11⁴⁾(B)
clamping hub
diameter

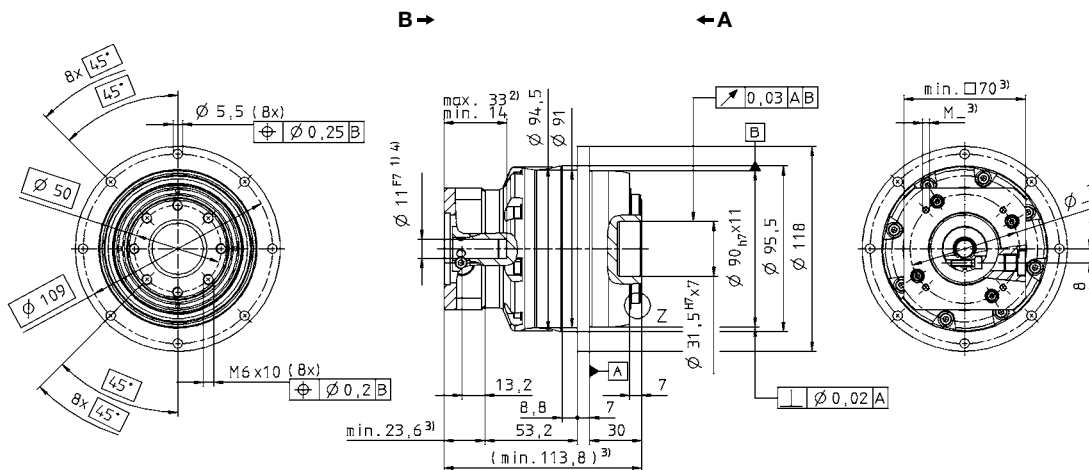

up to 14⁴⁾(C)
clamping hub
diameter

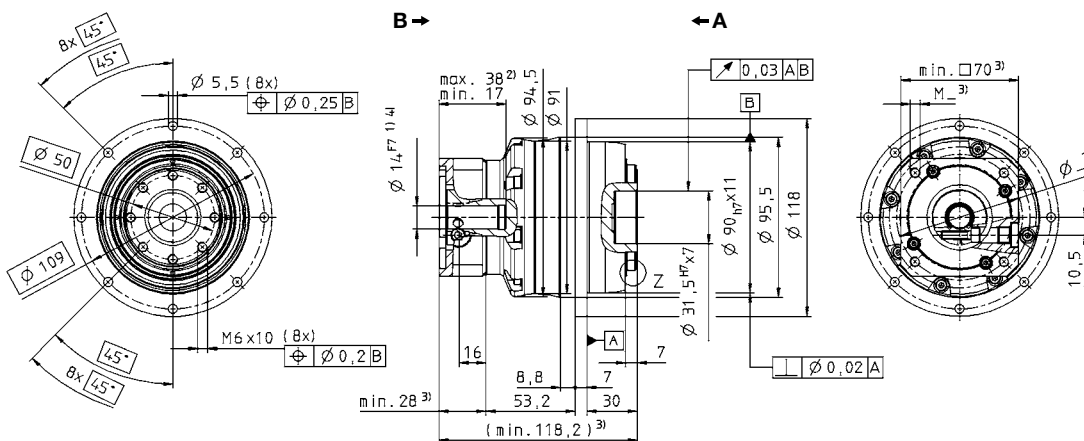

up to 19⁴⁾(E)
clamping hub
diameter

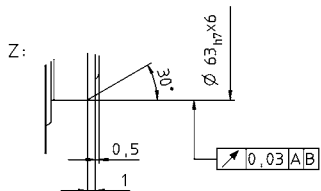
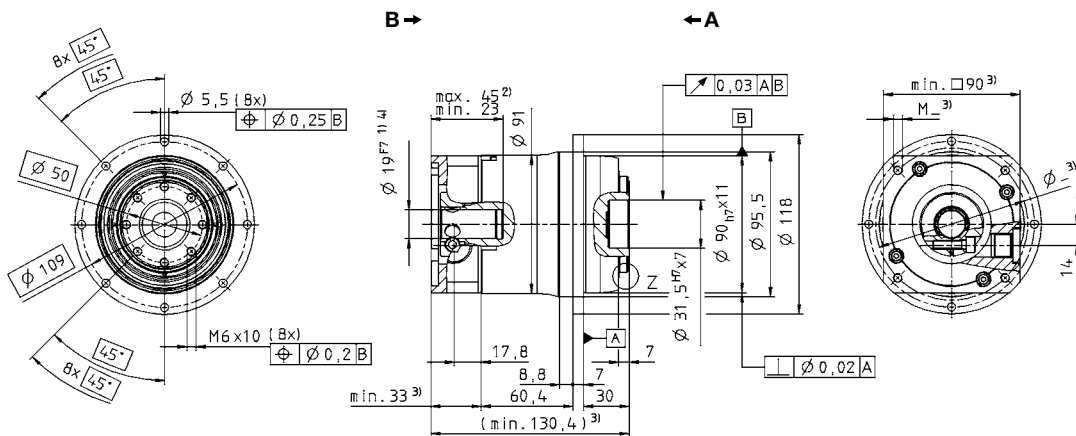

Non-tolerated dimensions ± 1 mm

- 1) Check motor shaft fit.
- 2) Min./Max. permissible motor shaft length. Longer motor shafts are adaptable, please contact us.
- 3) The dimensions depend on the motor.
- 4) Smaller motor shaft diameter is compensated by a bushing with a minimum thickness of 1 mm.

Motor mounting according to operating manual

TP



TP+ 010 MA HIGH TORQUE®

		2-stage				3-stage						
Ratio ^{a)}	<i>i</i>		22	27.5	38.5	55	88	110	154	220		
Max. acceleration torque (max. 1000 cycles per hour)	T_{2B}	Nm	230	230	230	230	230	230	230	230		
		in.lb	2036	2036	2036	2036	2036	2036	2036	2036		
Nominal output torque (with n_{1N})	T_{2N}	Nm	150	150	180	110	180	180	180	180		
		in.lb	1328	1328	1593	974	1593	1593	1593	1593		
Emergency stop torque (permitted 1000 times during the service life of the gearhead)	T_{2Not}	Nm	525	525	525	525	525	525	525	525		
		in.lb	4646	4646	4646	4646	4646	4646	4646	4646		
Nominal input speed (with T_{2N} and 20 °C ambient temperature) ^{b)}	n_{1N}	rpm	4000	4000	4000	4000	4500	4500	4500	4500		
Max. input speed	n_{1Max}	rpm	6000	6000	6000	6000	6000	6000	6000	6000		
Mean no load running torque (with $n_1=3000$ rpm and 20 °C gearhead temperature) ^{c)}	T_{012}	Nm	0.60	0.50	0.45	0.35	0.35	0.35	0.30	0.30		
		in.lb	5.30	4.40	4.00	3.10	3.10	3.10	2.70	2.70		
Max. torsional backlash	j_t	arcmin	≤ 1				≤ 1					
Torsional rigidity ^{c)}	C_{21}	Nm/ arcmin	43	43	43	42	42	42	42	42		
		in.lb/ arcmin	381	381	381	372	372	372	372	372		
Tilting rigidity	C_{2K}	Nm/ arcmin	225				225					
		in.lb/ arcmin	1991				1991					
Max. axial force ^{d)}	F_{2AMax}	N	2150				2150					
		lb _f	484				484					
Max. tilting moment	M_{2KMax}	Nm	400				400					
		in.lb	3540				3540					
Efficiency at full load	η	%	94				92					
Service life (For calculation, see the Chapter "Information")	L_n	h	> 20000				> 20000					
Weight incl. standard adapter plate	<i>m</i>	kg	3.2				3.6					
		lb _m	7.1				8.0					
Operating noise (with $n_1=3000$ rpm no load)	L_{PA}	dB(A)	≤ 60				≤ 60					
Max. permitted housing temperature	°C		+90									
	F		194									
Ambient temperature	°C		-15 to +40									
	F		5 to 104									
Lubrication	Lubricated for life											
Paint	Blue RAL 5002											
Direction of rotation	Motor and gearhead same direction											
Protection class	IP 65											
Moment of inertia (relates to the drive)	C	14	J_1	kgcm ²	0.21	0.18	0.16	0.14	0.16	0.15	0.14	0.13
				10 ⁻³ in.lb.in ²	0.19	0.16	0.14	0.12	0.14	0.13	0.12	0.12
Clamping hub diameter [mm]	E	19	J_1	kgcm ²	0.52	0.50	0.47	0.46	-	-	-	-
				10 ⁻³ in.lb.in ²	0.46	0.44	0.42	0.41	-	-	-	-

Reduced mass moments of inertia available on request.

^{a)} Other ratios available on request

^{b)} For higher ambient temperatures, please reduce input speed

^{c)} Valid for clamping hub diameter of 14 mm

^{d)} Refers to center of the output shaft or flange

View A

View B

2-stage:

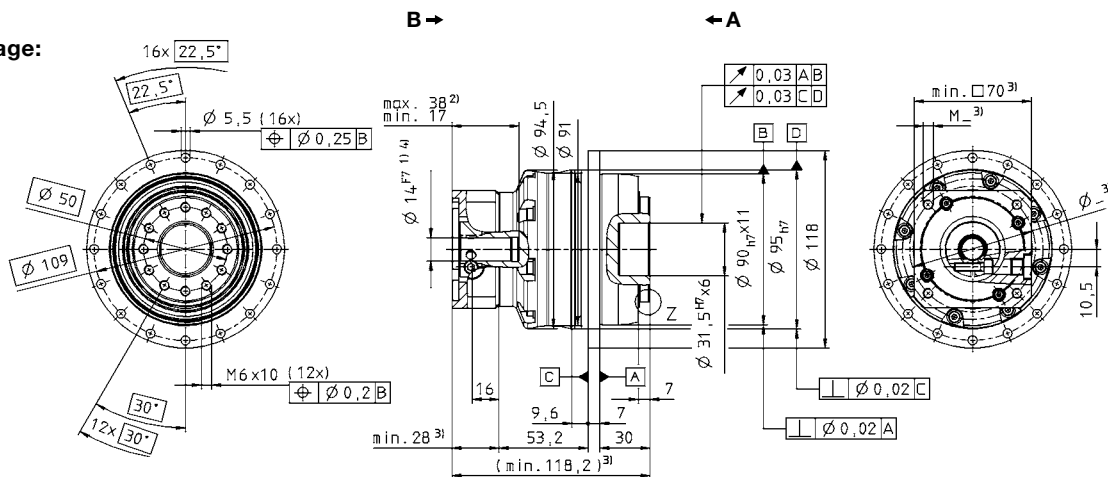

up to 14⁴⁾ (C)
clamping hub
diameter

Motor shaft diameter [mm]

up to 19⁴⁾ (E)
clamping hub
diameter

3-stage:

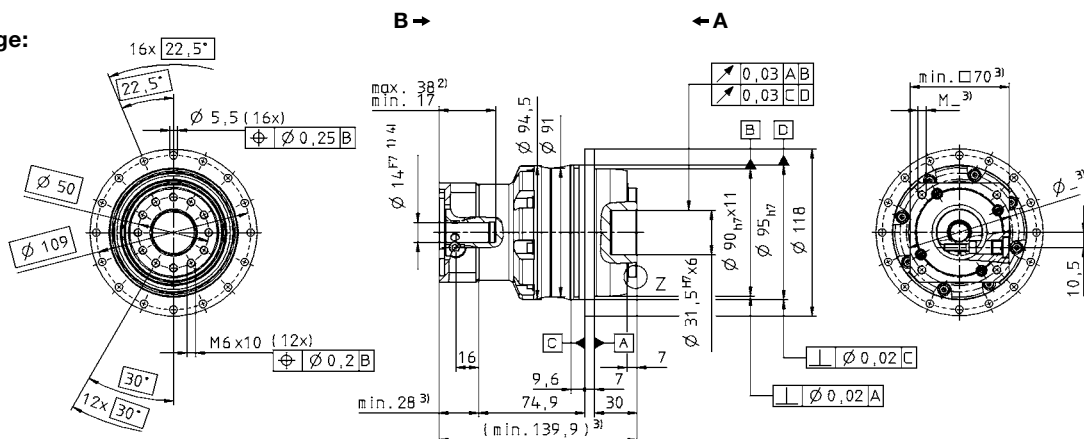

up to 14⁴⁾ (C)
clamping hub
diameter

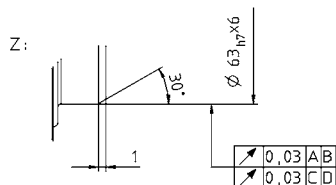

Non-tolerated dimensions ± 1 mm

- 1) Check motor shaft fit.
- 2) Min./Max. permissible motor shaft length. Longer motor shafts are adaptable, please contact us.
- 3) The dimensions depend on the motor.
- 4) Smaller motor shaft diameter is compensated by a bushing with a minimum thickness of 1 mm.

Motor mounting according to operating manual

TP



TP+ 025 MF 1-stage

				1-stage				
Ratio ^{a)}		<i>i</i>		4	5	7	10	
cymex [®] -optimized acceleration torque (please contact us regarding the design)	T_{2Bcym}	Nm		390	420	350	275	
		in.lb		3452	3717	3098	2434	
Max. acceleration torque (max. 1000 cycles per hour)	T_{2B}	Nm		350	380	330	265	
		in.lb		3098	3363	2921	2345	
Nominal output torque (with n_{2N})	T_{2N}	Nm		170	170	170	120	
		in.lb		1505	1505	1505	1062	
Emergency stop torque (permitted 1000 times during the service life of the gearhead)	T_{2Not}	Nm		625	625	625	625	
		in.lb		5531	5531	5531	5531	
Nominal input speed (with T_{2N} and 20 °C ambient temperature ^{b)})	n_{1N}	rpm		2300	2500	2500	2500	
Max. input speed	n_{1Max}	rpm		4500	4500	4500	4500	
Mean no load running torque (with $n_1=3000$ rpm and 20 °C gearhead temperature ^{c)})	T_{012}	Nm		3.3	2.7	2.0	1.4	
		in.lb		29.2	23.9	17.7	12.4	
Max. torsional backlash	j_t	arcmin		Standard ≤ 3 / Reduced ≤ 1				
Torsional rigidity ^{c)}	C_{I21}	Nm/ arcmin		80	86	76	62	
		in.lb/ arcmin		708	761	673	549	
Tilting rigidity	C_{2K}	Nm/ arcmin		550				
		in.lb/ arcmin		4868				
Max. axial force ^{d)}	F_{2AMax}	N		4150				
		lb _f		934				
Max. tilting moment	M_{2KMax}	Nm		440				
		in.lb		3894				
Efficiency at full load	η	%		97				
Service life (For calculation, see the Chapter "Information")	L_h	h		> 20000				
Weight incl. standard adapter plate	m	kg		6.5				
		lb _m		14.4				
Operating noise (with $i=10$ and $n_1=3000$ rpm no load)	L_{PA}	dB(A)		≤ 64				
Max. permitted housing temperature		°C		+90				
		F		194				
Ambient temperature		°C		-15 to +40				
		F		5 to 104				
Lubrication				Lubricated for life				
Paint				Blue RAL 5002				
Direction of rotation				Motor and gearhead same direction				
Protection class				IP 65				
Moment of inertia (relates to the drive)	E	19	J_1	kgcm ²	2.59	2.11	1.69	1.45
				10 ⁻⁴ in.lb.s ²	2.29	1.87	1.50	1.28
Clamping hub diameter [mm]	G	24	J_1	kgcm ²	3.28	2.80	2.38	2.14
				10 ⁻⁴ in.lb.s ²	2.90	2.48	2.11	1.89
	H	28	J_1	kgcm ²	2.89	2.41	1.99	1.75
				10 ⁻⁴ in.lb.s ²	2.56	2.13	1.76	1.55
K	38	J_1	kgcm ²	10.3	9.87	9.45	9.21	
			10 ⁻⁴ in.lb.s ²	9.11	8.73	8.36	8.15	

Reduced mass moments of inertia available on request.

^{a)} Other ratios available on request

^{b)} For higher ambient temperatures, please reduce input speed

^{c)} Valid for clamping hub diameter of 24 and 28 mm

^{d)} Refers to center of the output shaft or flange

up to 19⁴⁾(E)
clamping hub diameter

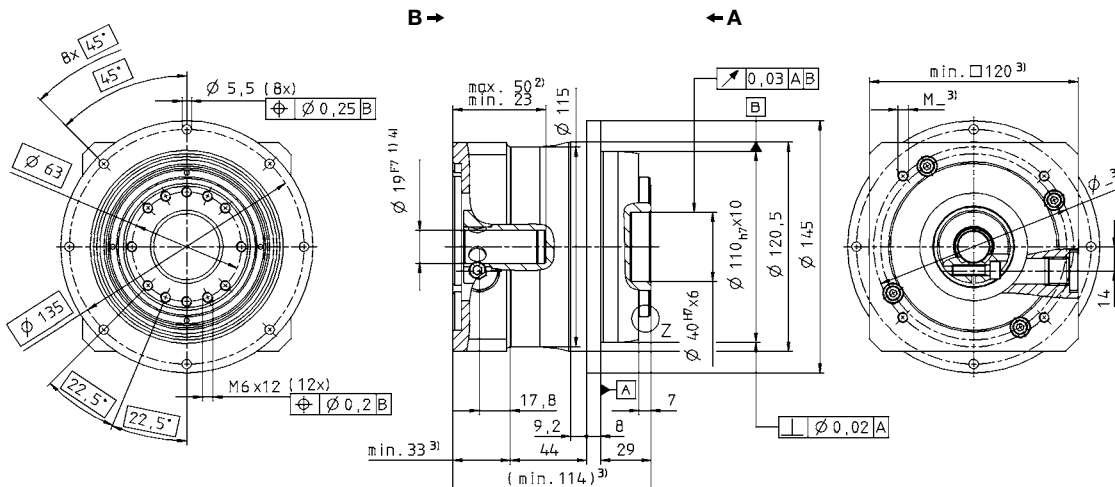

up to 24/28⁴⁾
(G/H) clamping hub diameter

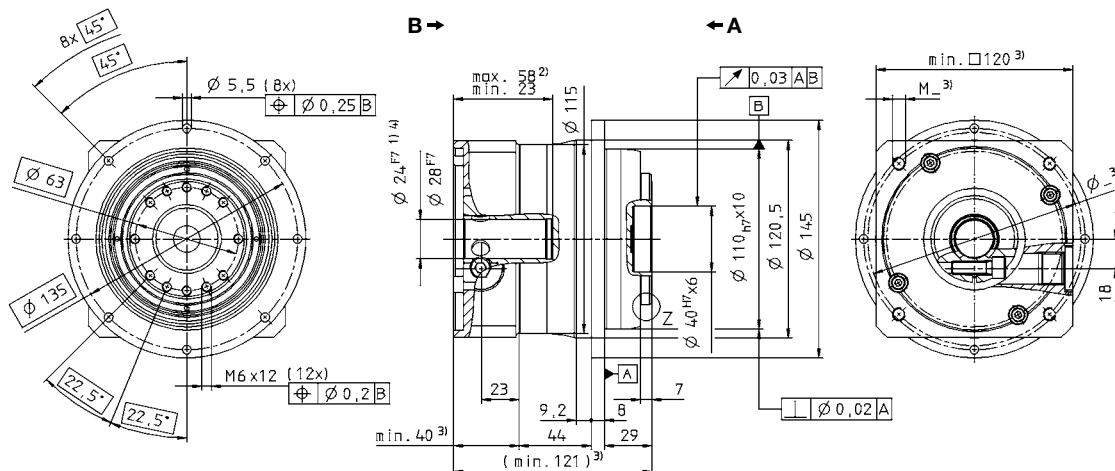

up to 38⁴⁾(K)
clamping hub diameter

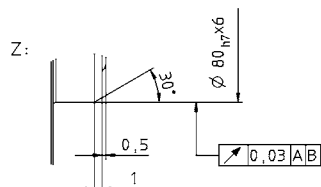
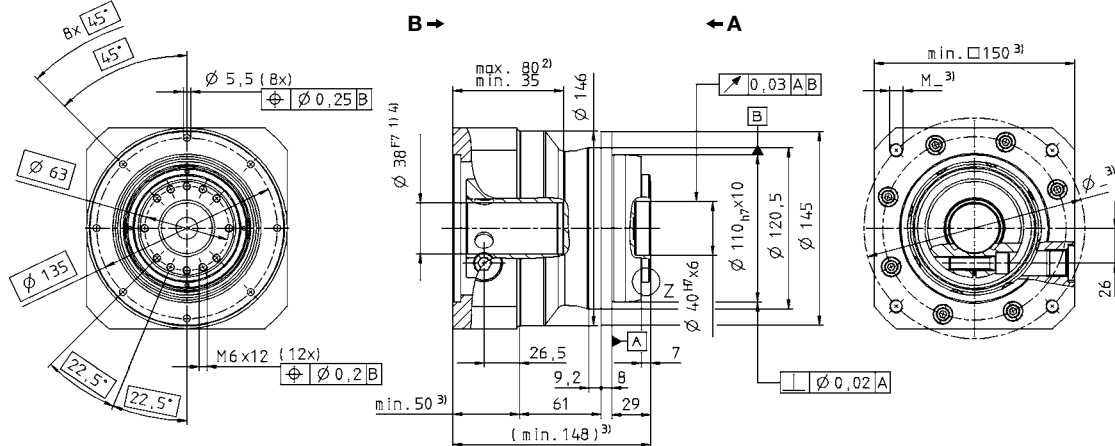

Non-tolerated dimensions ± 1 mm

- 1) Check motor shaft fit.
- 2) Min./Max. permissible motor shaft length. Longer motor shafts are adaptable, please contact us.
- 3) The dimensions depend on the motor.
- 4) Smaller motor shaft diameter is compensated by a bushing with a minimum thickness of 1 mm.

Motor mounting according to operating manual



TP+ 025 MF 2-stage

		2-stage															
Ratio ^{a)}	<i>i</i>		16	20	21	25	28	31	35	40	50	61	70	91	100		
cymex®-optimized acceleration torque (please contact us regarding the design)	T_{2Bcym}	Nm	390	390	–	420	390	–	420	390	420	–	350	–	275		
		in.lb	3452	3452	–	3717	3452	–	3717	3452	3717	–	3098	–	2434		
Max. acceleration torque (max. 1000 cycles per hour)	T_{2B}	Nm	350	350	300	380	350	300	380	350	380	280	330	250	265		
		in.lb	3098	3098	2655	3363	3098	2655	3363	3098	3363	2478	2921	2213	2345		
Nominal output torque (with n_{2N})	T_{2N}	Nm	200	210	170	200	210	190	220	200	220	170	200	100	120		
		in.lb	1770	1859	1505	1770	1859	1682	1947	1770	1947	1505	1770	885	1062		
Emergency stop torque (permitted 1000 times during the service life of the gearhead)	T_{2Nst}	Nm	625	625	625	625	625	625	625	625	625	625	625	625	625		
		in.lb	5531	5531	5531	5531	5531	5531	5531	5531	5531	5531	5531	5531	5531		
Nominal input speed (with T_{2N} and 20 °C ambient temperature) ^{b)}	n_{1N}	rpm	2800	2800	2800	2800	2800	2800	2800	2800	3100	3500	3500	4200	4200		
Max. input speed	n_{1Max}	rpm	6000	6000	6000	6000	6000	6000	6000	6000	6000	6000	6000	6000	6000		
Mean no load running torque (with $n_1=3000$ rpm and 20 °C gearhead temperature) ^{c)}	T_{012}	Nm	1.8	1.5	1.4	1.4	1.1	1.1	1.0	0.8	0.8	0.7	0.7	0.6	0.6		
		in.lb	15.9	13.3	12.4	12.4	9.7	9.7	8.9	7.1	7.1	6.2	6.2	5.3	5.3		
Max. torsional backlash	j_t	arcmin	Standard ≤ 3 / Reduced ≤ 1														
Torsional rigidity ^{c)}	C_{121}	Nm/arcmin	81	81	70	83	80	54	82	76	80	61	71	55	60		
		in.lb/arcmin	717	717	620	735	708	478	726	673	708	540	628	487	531		
Tilting rigidity	C_{2K}	Nm/arcmin	550														
		in.lb/arcmin	4867														
Max. axial force ^{d)}	F_{2AMax}	N	4150														
		lb _f	934														
Max. tilting moment	M_{2KMax}	Nm	440														
		in.lb	3894														
Efficiency at full load	η	%	94														
Service life (For calculation, see the Chapter "Information")	L_h	h	> 20000														
Weight incl. standard adapter plate	m	kg	6.7														
		lb _m	14.8														
Operating noise (with $i=100$ and $n_1=3000$ rpm no load)	L_{PA}	dB(A)	≤ 60														
Max. permitted housing temperature		°C	+90														
		F	194														
Ambient temperature		°C	-15 to +40														
		F	5 to 104														
Lubrication			Lubricated for life														
Paint			Blue RAL 5002														
Direction of rotation			Motor and gearhead same direction														
Protection class			IP 65														
Moment of inertia (relates to the drive)	C	14	J_1	kgcm ²	0.66	0.55	0.60	0.53	0.44	0.55	0.43	0.38	0.38	0.39	0.37	0.38	0.37
				10 ⁻³ in.lb.s ²	0.59	0.49	0.51	0.47	0.39	0.49	0.38	0.34	0.33	0.35	0.33	0.34	0.33
Clamping hub diameter [mm]	E	19	J_1	kgcm ²	0.83	0.71	0.77	0.69	0.61	0.72	0.60	0.55	0.54	0.55	0.54	0.54	0.54
				10 ⁻³ in.lb.s ²	0.73	0.63	0.68	0.61	0.54	0.64	0.53	0.49	0.48	0.4	0.48	0.48	0.48
	G	24	J_1	kgcm ²	2.20	2.08	2.14	2.06	1.98	2.09	1.97	1.92	1.92	1.92	1.91	1.92	1.91
				10 ⁻³ in.lb.s ²	1.95	1.84	1.89	1.82	1.75	1.85	1.74	1.70	1.70	1.70	1.70	1.69	1.70

Reduced mass moments of inertia available on request.

^{a)} Other ratios available on request

^{b)} For higher ambient temperatures, please reduce input speed

^{c)} Valid for clamping hub diameter of 19 mm

^{d)} Refers to center of the output shaft or flange

View A

View B

up to 14⁴⁾ (C)
clamping hub diameter

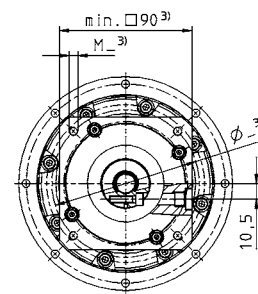
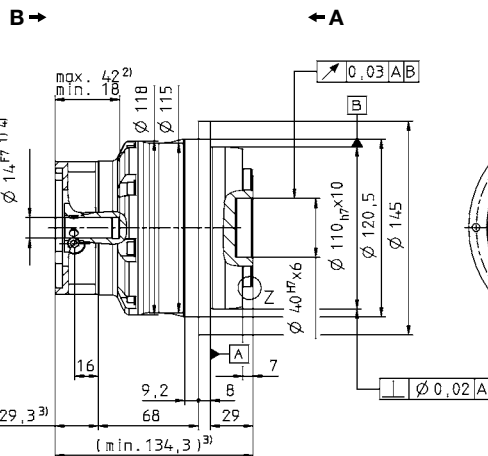
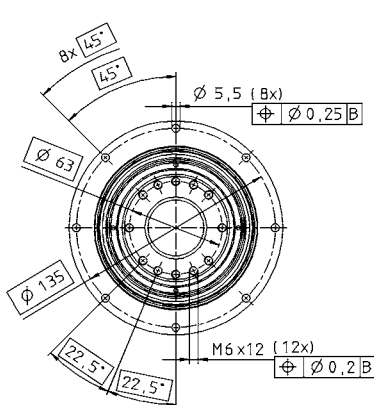

up to 19⁴⁾ (E)
clamping hub diameter

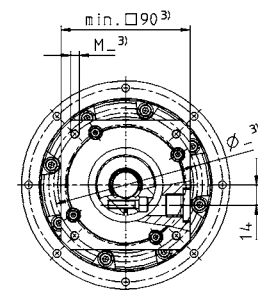
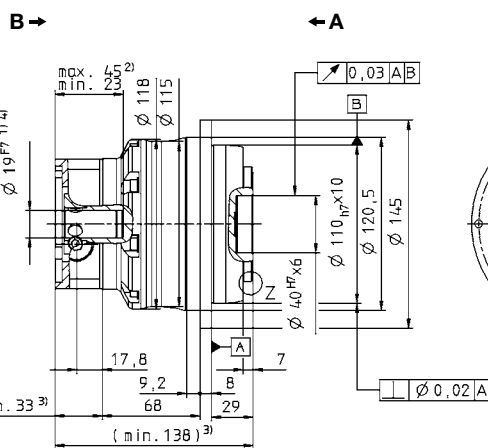
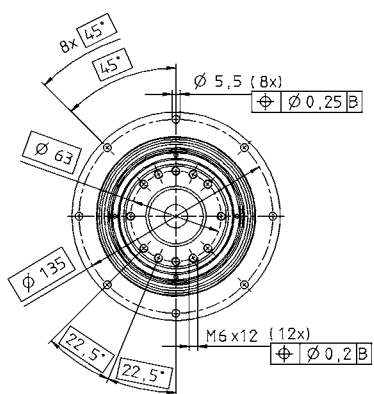

up to 24⁴⁾ (G)
clamping hub diameter

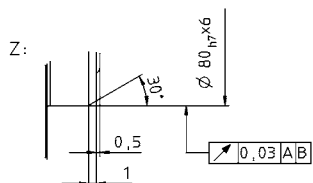
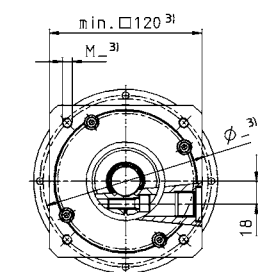
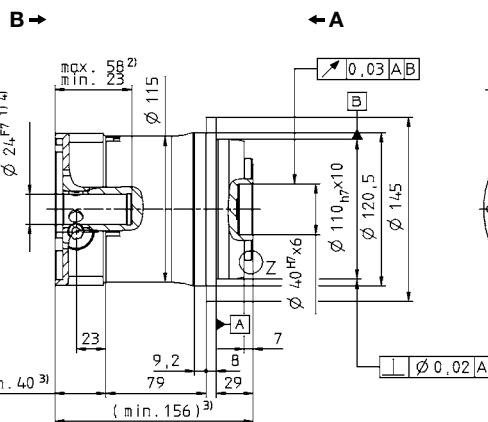
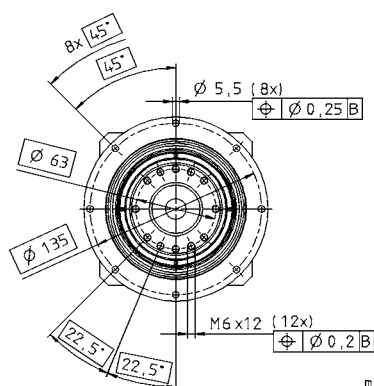

Non-tolerated dimensions ± 1 mm

- 1) Check motor shaft fit.
- 2) Min./Max. permissible motor shaft length. Longer motor shafts are adaptable, please contact us.
- 3) The dimensions depend on the motor.
- 4) Smaller motor shaft diameter is compensated by a bushing with a minimum thickness of 1 mm.

Motor mounting according to operating manual

TP



TP+ 025 MA HIGH TORQUE®

		2-stage				3-stage							
Ratio ^{a)}	<i>i</i>		22	27.5	38.5	55	66	88	110	154	220		
Max. acceleration torque (max. 1000 cycles per hour)	T_{2B}	Nm	530	530	530	530	480	480	480	480	480		
		in.lb	4691	4691	4691	4691	4248	4248	4248	4248	4248		
Nominal output torque (with n_{1N})	T_{2N}	Nm	320	350	375	375	260	260	260	260	260		
		in.lb	2832	3098	3319	3319	2301	2301	2301	2301	2301		
Emergency stop torque (permitted 1000 times during the service life of the gearhead)	T_{2Not}	Nm	1200	1200	1200	1200	1200	1200	1200	1200	1200		
		in.lb	10620	10620	10620	10620	10620	10620	10620	10620	10620		
Nominal input speed (with T_{2N} and 20 °C ambient temperature) ^{b)}	n_{1N}	rpm	3500	3500	3500	3500	4000	4000	4000	4000	4000		
Max. input speed	n_{1Max}	rpm	6000	6000	6000	6000	6000	6000	6000	6000	6000		
Mean no load running torque (with $n_1=3000$ rpm and 20 °C gearhead temperature) ^{c)}	T_{012}	Nm	1.1	1.0	0.8	0.6	0.7	0.7	0.6	0.4	0.4		
		in.lb	9.7	8.9	7.1	5.3	6.2	6.2	5.3	3.5	3.5		
Max. torsional backlash	j_t	arcmin	≤ 1				≤ 1						
Torsional rigidity ^{c)}	C_{t21}	Nm/arcmin	105	105	105	100	95	95	95	95	95		
		in.lb/arcmin	929	929	929	885	841	841	841	841	841		
Tilting rigidity	C_{2K}	Nm/arcmin	550				550						
		in.lb/arcmin	4868				4868						
Max. axial force ^{d)}	F_{2AMax}	N	4150				4150						
		lb _f	934				934						
Max. tilting moment	M_{2KMax}	Nm	550				550						
		in.lb	4868				4868						
Efficiency at full load	η	%	94				92						
Service life (For calculation, see the Chapter "Information")	L_h	h	> 20000				> 20000						
Weight incl. standard adapter plate	<i>m</i>	kg	5.6				6.1						
		lb _m	12.4				13.5						
Operating noise (with $n_1=3000$ rpm no load)	L_{PA}	dB(A)	≤ 62				≤ 62						
Max. permitted housing temperature	°C		+90										
	F		194										
Ambient temperature	°C		-15 to +40										
	F		5 to 104										
Lubrication	Lubricated for life												
Paint	Blue RAL 5002												
Direction of rotation	Motor and gearhead same direction												
Protection class	IP 65												
Moment of inertia (relates to the drive)	E	19	J_1	kgcm ²	0.87	0.70	0.60	0.55	0.63	0.56	0.53	0.51	0.50
				10 ⁻³ in.lb.s ²	0.77	0.62	0.53	0.49	0.56	0.50	0.47	0.45	0.44
Clamping hub diameter [mm]	G	24	J_1	kgcm ²	2.39	2.22	2.12	2.07	-	-	-	-	-
				10 ⁻³ in.lb.s ²	2.12	1.96	1.88	1.83	-	-	-	-	-

Reduced mass moments of inertia available on request.

^{a)} Other ratios available on request

^{b)} For higher ambient temperatures, please reduce input speed

^{c)} Valid for clamping hub diameter of 19 mm

^{d)} Refers to center of the output shaft or flange

View A

View B

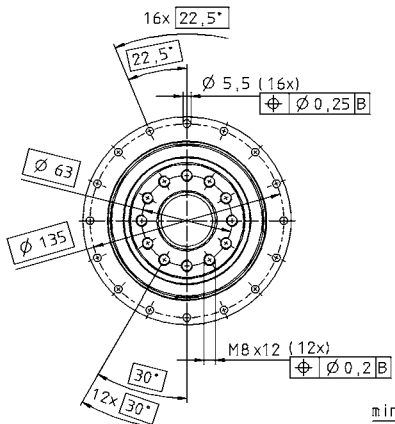
2-stage:

B →

← A

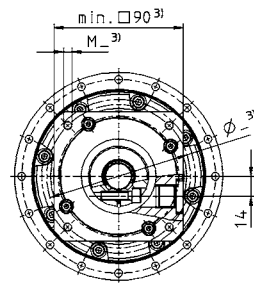
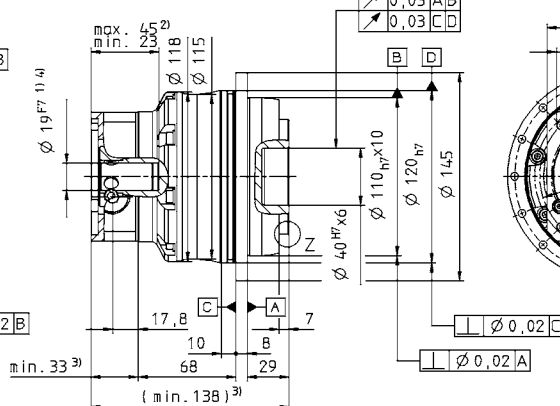

 up to 19⁴⁾ (E)
clamping hub
diameter

TP

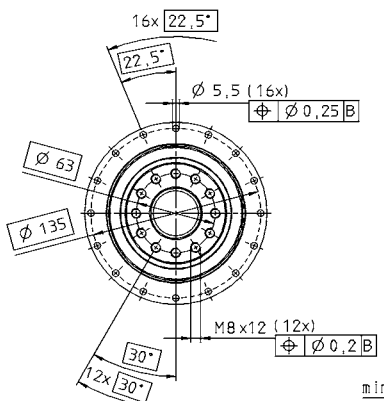

Motor shaft diameter [mm]

 up to 24⁴⁾ (G)
clamping hub
diameter

3-stage:

B →

← A

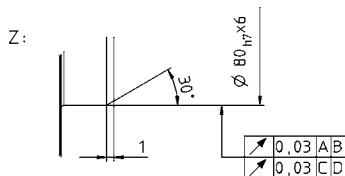
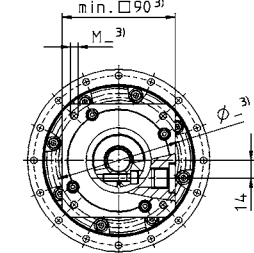
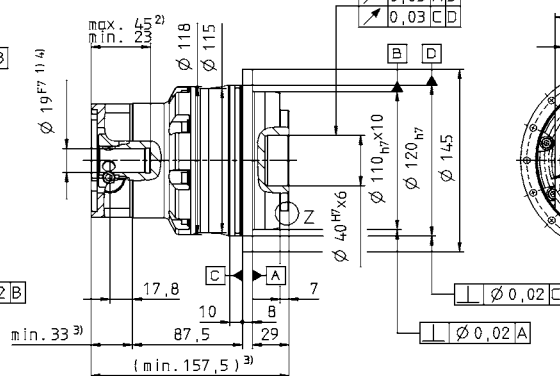

Non-tolerated dimensions ±1 mm

- 1) Check motor shaft fit.
- 2) Min./Max. permissible motor shaft length. Longer motor shafts are adaptable, please contact us.
- 3) The dimensions depend on the motor.
- 4) Smaller motor shaft diameter is compensated by a bushing with a minimum thickness of 1 mm.

Motor mounting according to operating manual

TP+ 050 MF 1-stage

				1-stage				
Ratio ^{a)}		<i>i</i>		4	5	7	10	
cymex [®] -optimized acceleration torque (please contact us regarding the design)	T_{2Bcym}	Nm		750	800	–	600	
		in.lb		6638	7080	–	5310	
Max. acceleration torque (max. 1000 cycles per hour)	T_{2B}	Nm		700	700	700	540	
		in.lb		6195	6195	6195	4779	
Nominal output torque (with n_N)	T_{2N}	Nm		370	370	370	240	
		in.lb		3275	3275	3275	2124	
Emergency stop torque (permitted 1000 times during the service life of the gearhead)	T_{2Not}	Nm		1250	1250	1250	1250	
		in.lb		11063	11063	11063	11063	
Nominal input speed (with T_{2N} and 20 °C ambient temperature ^{b)})	n_{1N}	rpm		1900	2000	2500	2500	
Max. input speed	n_{1Max}	rpm		4000	4000	4000	4000	
Mean no load running torque (with $n_i=3000$ rpm and 20 °C gearhead temperature ^{c)})	T_{012}	Nm		8.1	6.6	4.8	3.5	
		in.lb		71.7	58.4	42.5	31.0	
Max. torsional backlash	j_t	arcmin		Standard ≤ 3 / Reduced ≤ 1				
Torsional rigidity ^{c)}	C_{t21}	Nm/ arcmin		190	187	159	123	
		in.lb/ arcmin		1682	1655	1407	1089	
Tilting rigidity	C_{2K}	Nm/ arcmin		560				
		in.lb/ arcmin		4956				
Max. axial force ^{d)}	F_{2AMax}	N		6130				
		lb _f		1379				
Max. tilting moment	M_{2KMax}	Nm		1335				
		in.lb		11815				
Efficiency at full load	η	%		97				
Service life (For calculation, see the Chapter "Information")	L_h	h		> 20000				
Weight incl. standard adapter plate	m	kg		14.0				
		lb _m		30.9				
Operating noise (with $i=10$ and $n_i=3000$ rpm no load)	L_{PA}	dB(A)		≤ 65				
Max. permitted housing temperature		°C		+90				
		F		194				
Ambient temperature		°C		-15 to +40				
		F		5 to 104				
Lubrication				Lubricated for life				
Paint				Blue RAL 5002				
Direction of rotation				Motor and gearhead same direction				
Protection class				IP 65				
Moment of inertia (relates to the drive)	G	24	J_1	kgcm ²	9.47	7.85	6.39	5.54
				10 ⁻⁴ in.lb.s ²	8.38	6.95	5.66	4.90
Clamping hub diameter [mm]	I	32	J_1	kgcm ²	12.6	11.0	9.55	8.71
				10 ⁻⁴ in.lb.s ²	11.1	9.74	8.45	7.70
	K	38	J_1	kgcm ²	13.7	12.1	10.6	9.78
				10 ⁻⁴ in.lb.s ²	12.1	10.7	9.38	8.65
M	48	J_1	kgcm ²	28.3	26.7	25.3	24.4	
			10 ⁻⁴ in.lb.s ²	25.0	23.6	22.4	21.6	

Reduced mass moments of inertia available on request.

^{a)} Other ratios available on request

^{b)} For higher ambient temperatures, please reduce input speed

^{c)} Valid for clamping hub diameter of 32 and 38 mm

^{d)} Refers to center of the output shaft or flange

View A

View B

up to 24⁴⁾ (G)
clamping hub
diameter

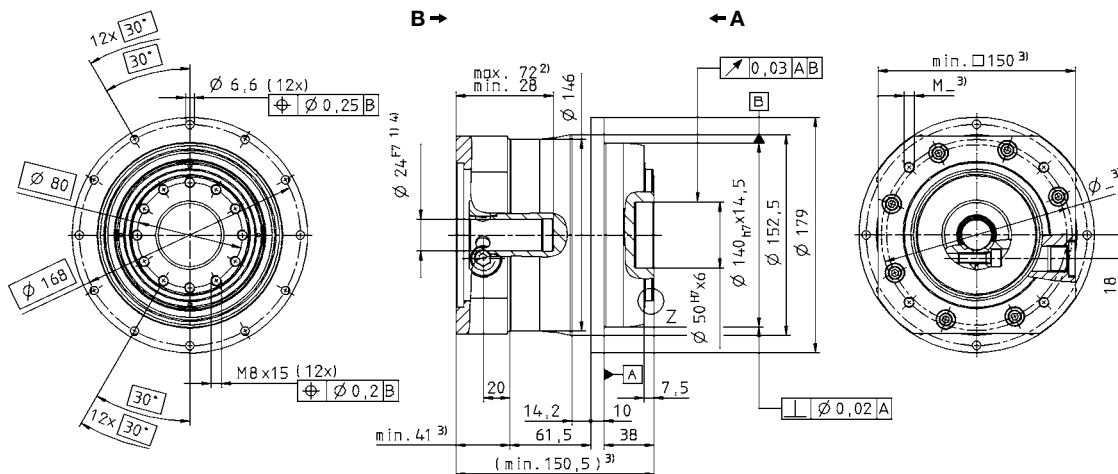

Motor shaft diameter [mm]

up to 32/38⁴⁾
(I/K) clamping hub
diameter

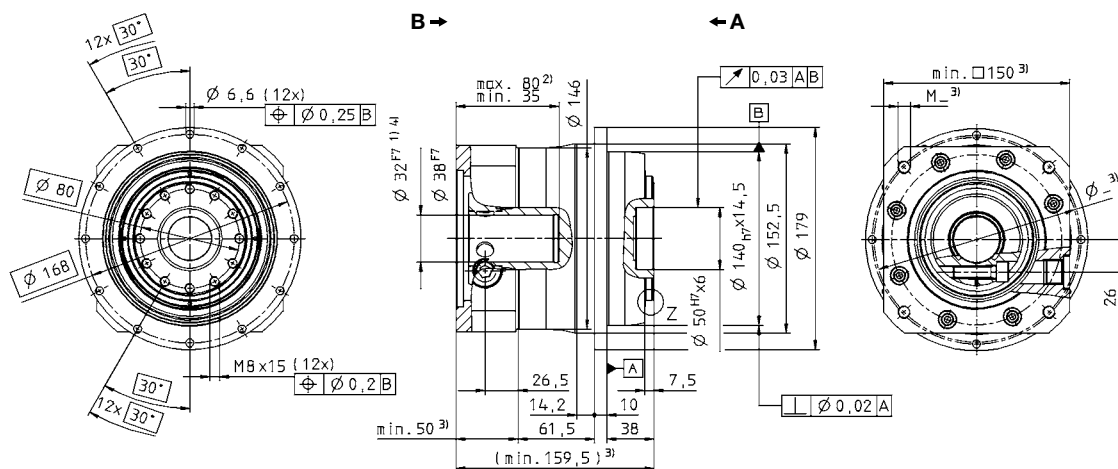

up to 48⁴⁾ (M)
clamping hub
diameter

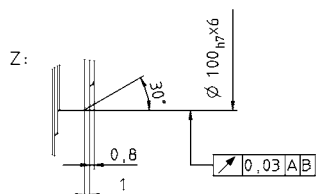
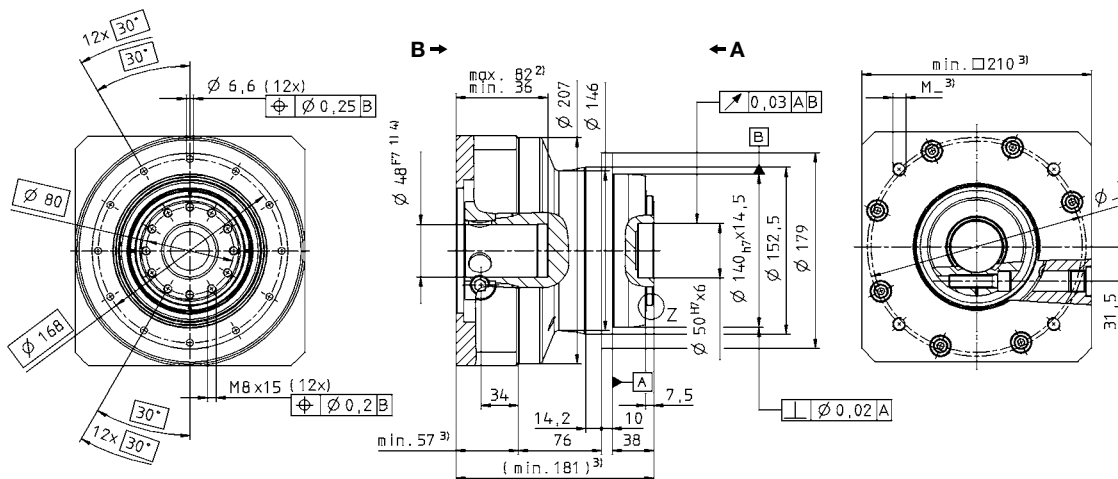

Non-tolerated dimensions ± 1 mm

- 1) Check motor shaft fit.
- 2) Min./Max. permissible motor shaft length. Longer motor shafts are adaptable, please contact us.
- 3) The dimensions depend on the motor.
- 4) Smaller motor shaft diameter is compensated by a bushing with a minimum thickness of 1 mm.

Motor mounting according to operating manual

TP



TP+ 050 MF 2-stage

		2-stage															
Ratio ^{a)}	<i>i</i>		16	20	21	25	28	31	35	40	50	61	70	91	100		
cymex®-optimized acceleration torque (please contact us regarding the design)	T_{2Bcym}	Nm	800	800	–	800	800	–	800	800	800	–	–	–	600		
		in.lb	7080	7080	–	7080	7080	–	7080	7080	7080	–	–	–	5310		
Max. acceleration torque (max. 1000 cycles per hour)	T_{2B}	Nm	750	750	600	750	750	620	750	750	750	550	700	500	540		
		in.lb	6638	6638	5310	6638	6638	5487	6638	6638	6638	4868	6195	4425	4779		
Nominal output torque (with n_{2N})	T_{2N}	Nm	400	400	350	400	400	400	400	400	400	350	400	220	240		
		in.lb	3540	3540	3098	3540	3540	3540	3540	3540	3540	3098	3540	1947	2124		
Emergency stop torque (permitted 1000 times during the service life of the gearhead)	T_{2Not}	Nm	1250	1250	1250	1250	1250	1250	1250	1250	1250	1250	1250	1250	1250		
		in.lb	11063	11063	11063	11063	11063	11063	11063	11063	11063	11063	11063	11063	11063		
Nominal input speed (with T_{2N} and 20 °C ambient temperature) ^{b)}	n_{1N}	rpm	2900	2900	2900	2900	2900	2900	2900	2900	3200	3200	3200	3900	3900		
Max. input speed	n_{1Max}	rpm	5000	5000	5000	5000	5000	5000	5000	5000	5000	5000	5000	5000	5000		
Mean no load running torque (with $n_1=3000$ rpm and 20 °C gearhead temperature) ^{c)}	T_{012}	Nm	4.2	3.4	3.3	3.1	2.5	2.4	2.3	1.8	1.7	1.5	1.5	1.4	1.3		
		in.lb	37.2	30.1	29.2	27.4	22.1	21.2	20.4	15.9	15.1	13.3	13.3	12.4	11.5		
Max. torsional backlash	j_t	arcmin	Standard ≤ 3 / Reduced ≤ 1														
Torsional rigidity ^{c)}	C_{121}	Nm/arcmin	180	185	145	180	180	130	175	175	175	123	145	100	115		
		in.lb/arcmin	1593	1637	1283	1593	1593	1151	1549	1549	1549	1089	1283	885	1018		
Tilting rigidity	C_{2K}	Nm/arcmin	560														
		in.lb/arcmin	4956														
Max. axial force ^{d)}	F_{2AMax}	N	6130														
		lb _f	1379														
Max. tilting moment	M_{2KMax}	Nm	1335														
		in.lb	11815														
Efficiency at full load	η	%	94														
Service life (For calculation, see the Chapter "Information")	L_h	h	> 20000														
Weight incl. standard adapter plate	m	kg	14.1														
		lb _m	31.2														
Operating noise (with $i=100$ and $n_1=3000$ rpm no load)	L_{PA}	dB(A)	≤ 63														
Max. permitted housing temperature		°C	+90														
		F	194														
Ambient temperature		°C	-15 to +40														
		F	5 to 104														
Lubrication			Lubricated for life														
Paint			Blue RAL 5002														
Direction of rotation			Motor and gearhead same direction														
Protection class			IP 65														
Moment of inertia (relates to the drive)	E	19	J_1	kgcm ²	2.53	2.07	2.30	2.01	1.67	2.12	1.64	1.44	1.42	1.46	1.41	1.43	1.40
				10 ⁻³ in.lb.s ²	2.24	1.83	2.04	1.78	1.48	1.88	1.45	1.27	1.26	1.29	1.25	1.27	1.24
Clamping hub diameter [mm]	G	24	J_1	kgcm ²	3.22	2.77	2.99	2.70	2.36	2.81	2.33	2.13	2.12	2.15	2.10	2.12	2.09
				10 ⁻³ in.lb.s ²	2.85	2.45	2.65	2.39	2.09	2.49	2.06	1.89	1.88	1.90	1.86	1.88	1.85
	K	38	J_1	kgcm ²	10.3	9.83	10.1	9.77	9.43	9.88	9.40	9.20	9.18	9.22	9.17	9.19	9.16
				10 ⁻³ in.lb.s ²	9.11	8.70	8.94	8.64	8.35	8.74	8.32	8.14	8.12	8.16	8.12	8.13	8.11

Reduced mass moments of inertia available on request.

^{a)} Other ratios available on request

^{b)} For higher ambient temperatures, please reduce input speed

^{c)} Valid for clamping hub diameter of 24 mm

^{d)} Refers to center of the output shaft or flange

View A

View B

up to 19⁴⁾ (E)
clamping hub
diameter

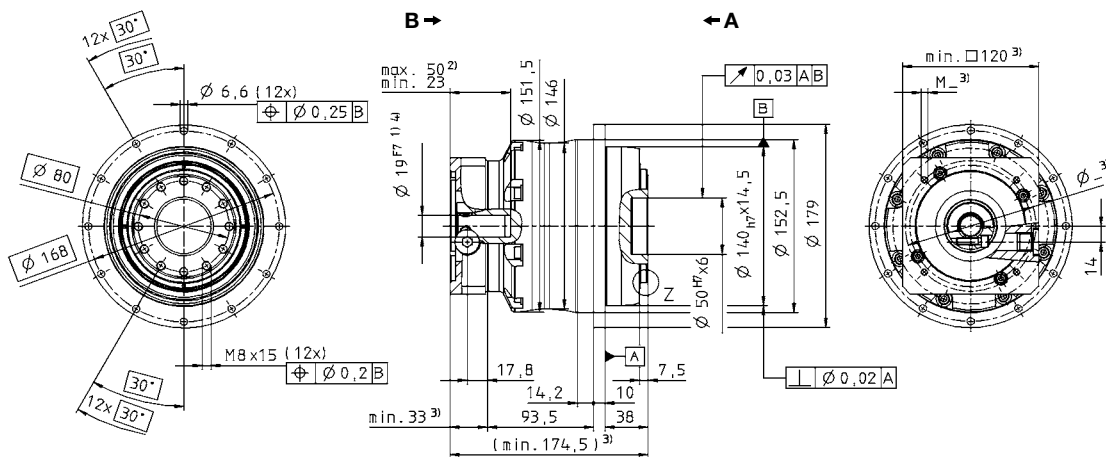

up to 24⁴⁾ (G)
clamping hub
diameter

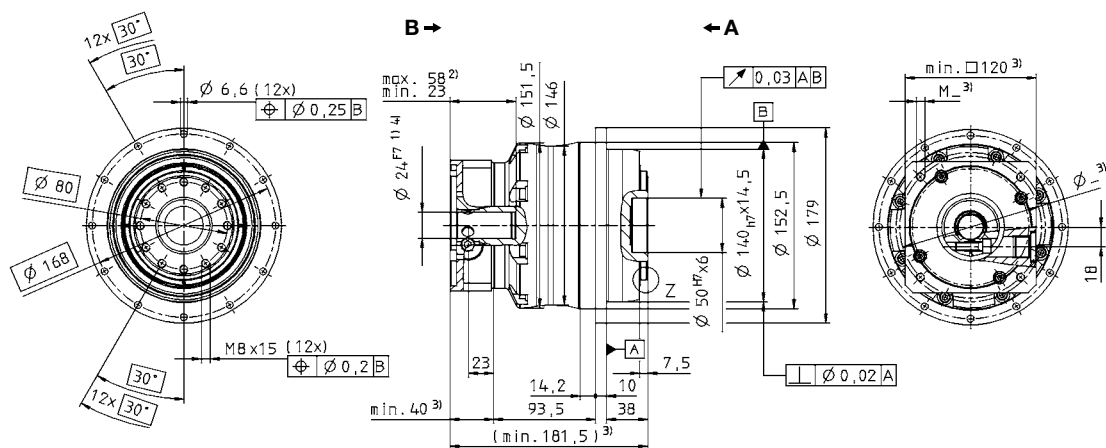

up to 38⁴⁾ (K)
clamping hub
diameter

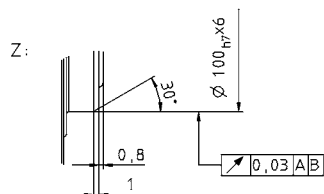
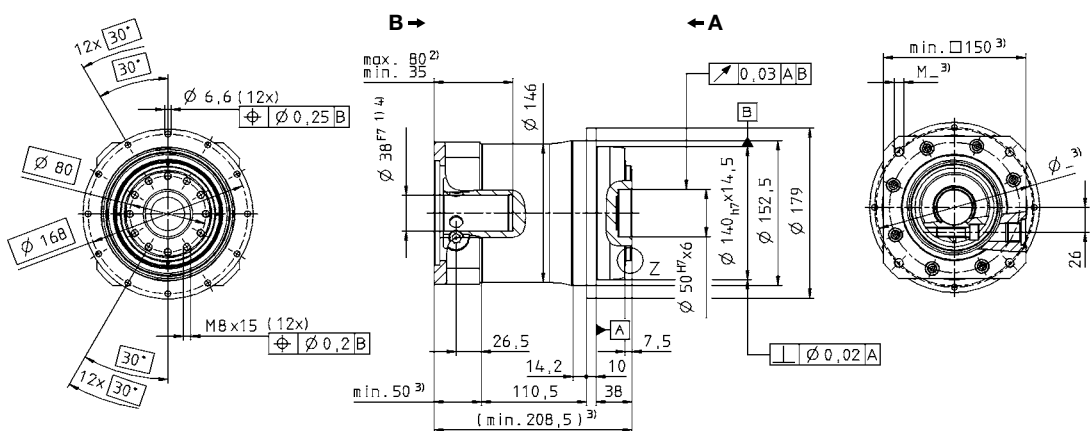

Non-tolerated dimensions ± 1 mm

- 1) Check motor shaft fit.
- 2) Min./Max. permissible motor shaft length. Longer motor shafts are adaptable, please contact us.
- 3) The dimensions depend on the motor.
- 4) Smaller motor shaft diameter is compensated by a bushing with a minimum thickness of 1 mm.

Motor mounting according to operating manual

TP



TP+ 050 MA HIGH TORQUE®

		2-stage				3-stage							
Ratio ^{a)}	<i>i</i>		22	27.5	38.5	55	66	88	110	154	220		
Max. acceleration torque (max. 1000 cycles per hour)	T_{2B}	Nm	950	950	950	950	950	950	950	950	950		
		in.lb	8408	8408	8408	8408	8408	8408	8408	8408	8408		
Nominal output torque (with n_{1N})	T_{2N}	Nm	575	600	650	675	675	675	675	675	675		
		in.lb	5089	5310	5753	5974	5974	5974	5974	5974	5974		
Emergency stop torque (permitted 1000 times during the service life of the gearhead)	T_{2Not}	Nm	2375	2375	2375	2375	2375	2375	2375	2375	2375		
		in.lb	21019	21019	21019	21019	21019	21019	21019	21019	21019		
Nominal input speed (with T_{2N} and 20 °C ambient temperature) ^{b)}	n_{1N}	rpm	3000	3000	3000	3000	3500	3500	3500	3500	3500		
Max. input speed	n_{1Max}	rpm	5000	5000	5000	5000	5000	5000	5000	5000	5000		
Mean no load running torque (with $n_1=3000$ rpm and 20 °C gearhead temperature) ^{c)}	T_{012}	Nm	3.7	2.9	2.0	1.7	2.0	1.6	1.4	0.9	0.7		
		in.lb	32.7	25.7	17.7	15.0	17.7	14.2	12.4	8.0	6.2		
Max. torsional backlash	j_t	arcmin	≤ 1				≤ 1						
Torsional rigidity ^{c)}	C_{t21}	Nm/arcmin	220	220	220	220	205	205	205	205	205		
		in.lb/arcmin	1947	1947	1947	1947	1814	1814	1814	1814	1814		
Tilting rigidity	C_{2K}	Nm/arcmin	560				560						
		in.lb/arcmin	4956				4956						
Max. axial force ^{d)}	F_{2AMax}	N	6130				6130						
		lb _f	1379				1379						
Max. tilting moment	M_{2KMax}	Nm	1335				1335						
		in.lb	11815				11815						
Efficiency at full load	η	%	94				92						
Service life (For calculation, see the Chapter "Information")	L_h	h	> 20000				> 20000						
Weight incl. standard adapter plate	<i>m</i>	kg	12.5				13.4						
		lb _m	27.6				29.6						
Operating noise (with $n_1=3000$ rpm no load)	L_{PA}	dB(A)	≤ 64				≤ 64						
Max. permitted housing temperature	°C		+90										
	F		194										
Ambient temperature	°C		-15 to +40										
	F		5 to 104										
Lubrication	Lubricated for life												
Paint	Blue RAL 5002												
Direction of rotation	Motor and gearhead same direction												
Protection class	IP 65												
Moment of inertia (relates to the drive)	G	24	J_1	kgcm ²	3.76	3.32	3.01	2.82	2.61	2.42	2.22	2.12	2.07
				10 ⁻³ in.lb.s ²	3.33	2.94	2.66	2.50	2.31	2.14	1.96	1.88	1.83
Clamping hub diameter [mm]	K	38	J_1	kgcm ²	10.7	10.3	9.92	9.73	-	-	-	-	-
				10 ⁻³ in.lb.s ²	9.47	9.11	8.78	8.61	-	-	-	-	-

Reduced mass moments of inertia available on request.

^{a)} Other ratios available on request

^{b)} For higher ambient temperatures, please reduce input speed

^{c)} Valid for clamping hub diameter of 24 mm

^{d)} Refers to center of the output shaft or flange

View A

View B

2-stage:

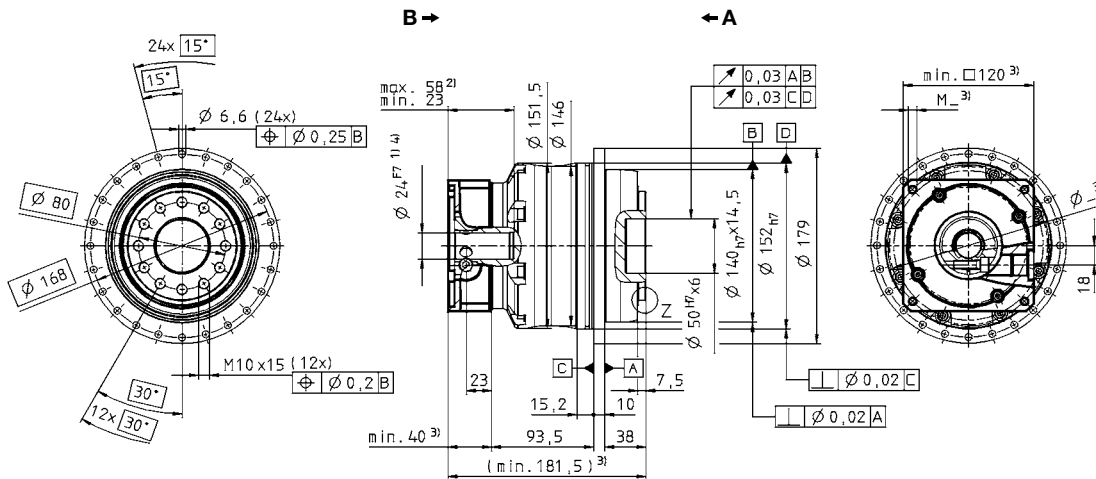

up to 24⁴⁾ (G)
clamping hub
diameter

Motor shaft diameter [mm]

up to 38⁴⁾ (K)
clamping hub
diameter

3-stage:

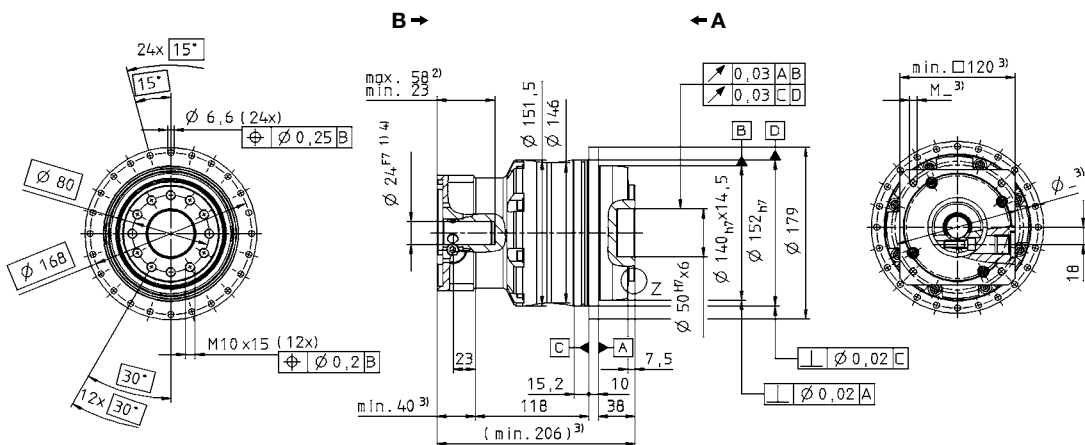

up to 24⁴⁾ (G)
clamping hub
diameter

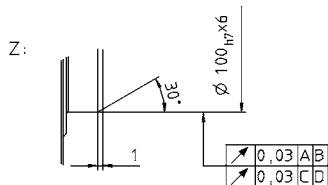

Non-tolerated dimensions ±1 mm

- 1) Check motor shaft fit.
- 2) Min./Max. permissible motor shaft length. Longer motor shafts are adaptable, please contact us.
- 3) The dimensions depend on the motor.
- 4) Smaller motor shaft diameter is compensated by a bushing with a minimum thickness of 1 mm.

⚠ Motor mounting according to operating manual

TP



TP+ 110 MF 1-stage

				1-stage				
Ratio ^{a)}		<i>i</i>		4	5	7	10	
cymex®-optimized acceleration torque (please contact us regarding the design)	T_{2Bcym}	Nm		1900	2000	1900	1500	
		in.lb		16815	17700	16815	13275	
Max. acceleration torque (max. 1000 cycles per hour)	T_{2B}	Nm		1600	1600	1600	1400	
		in.lb		14160	14160	14160	12390	
Nominal output torque (with n_n)	T_{2N}	Nm		700	750	750	750	
		in.lb		6195	6638	6638	6638	
Emergency stop torque (permitted 1000 times during the service life of the gearhead)	T_{2Not}	Nm		2750	2750	2750	2750	
		in.lb		24338	24338	24338	24338	
Nominal input speed (with T_{2N} and 20 °C ambient temperature) ^{b)}	n_{1N}	rpm		1400	1500	2000	2000	
Max. input speed	n_{1Max}	rpm		3500	3500	3500	3500	
Mean no load running torque (with $n_n=3000$ rpm and 20 °C gearhead temperature) ^{c)}	T_{012}	Nm		15.6	12.7	9.4	7.0	
		in.lb		138.1	112.4	83.2	62.0	
Max. torsional backlash	j_t	arcmin		Standard ≤ 3 / Reduced ≤ 1				
Torsional rigidity ^{c)}	C_{I21}	Nm/ arcmin		610	610	550	445	
		in.lb/ arcmin		5399	5399	4868	3938	
Tilting rigidity	C_{2K}	Nm/ arcmin		1452				
		in.lb/ arcmin		12850				
Max. axial force ^{d)}	F_{2AMax}	N		10050				
		lb _f		2261				
Max. tilting moment	M_{2KMMax}	Nm		3280				
		in.lb		29028				
Efficiency at full load	η	%		97				
Service life (For calculation, see the Chapter "Information")	L_h	h		> 20000				
Weight incl. standard adapter plate	m	kg		30.0				
		lb _m		66				
Operating noise (with $i=10$ and $n_n=3000$ rpm no load)	L_{PA}	dB(A)		≤ 66				
Max. permitted housing temperature		°C		+90				
		F		194				
Ambient temperature		°C		-15 to +40				
		F		5 to 104				
Lubrication				Lubricated for life				
Paint				Blue RAL 5002				
Direction of rotation				Motor and gearhead same direction				
Protection class				IP 65				
Moment of inertia (relates to the drive)	K	38	J_1	kgcm ²	44.5	34.6	25.5	20.6
				10 ⁻³ in.lb.s ²	39.4	30.6	22.6	18.2
Clamping hub diameter [mm]	M	48	J_1	kgcm ²	51.8	41.9	32.9	28.0
				10 ⁻³ in.lb.s ²	45.8	37.1	29.1	24.8

Reduced mass moments of inertia available on request.

^{a)} Other ratios available on request

^{b)} For higher ambient temperatures, please reduce input speed

^{c)} Valid for clamping hub diameter of 48 mm

^{d)} Refers to center of the output shaft or flange

View A

View B

Motor shaft diameter [mm]

 up to 38³⁾ (K)
clamping hub
diameter

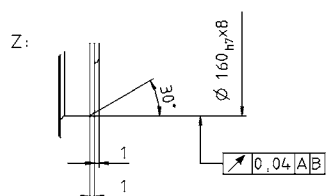
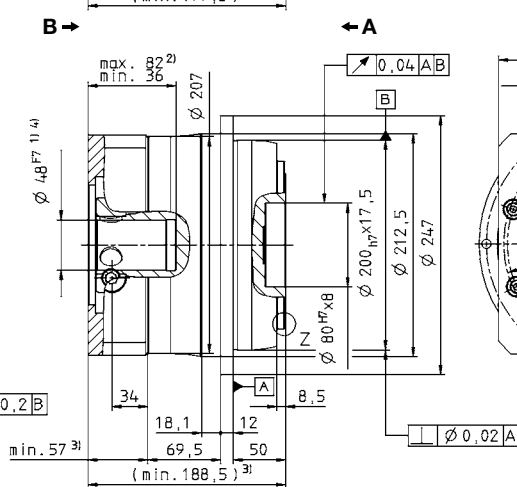
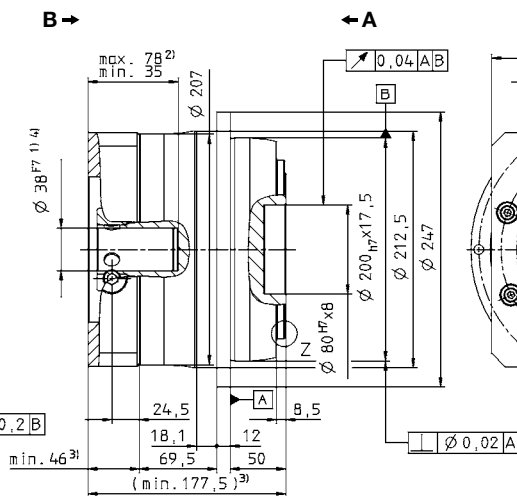
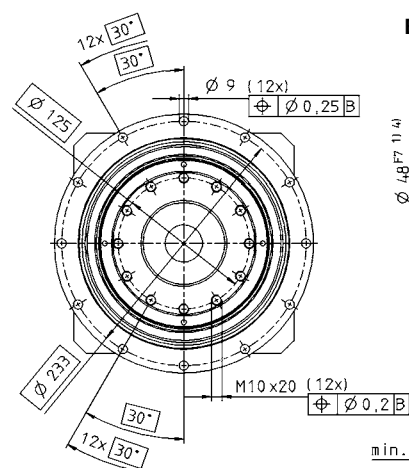
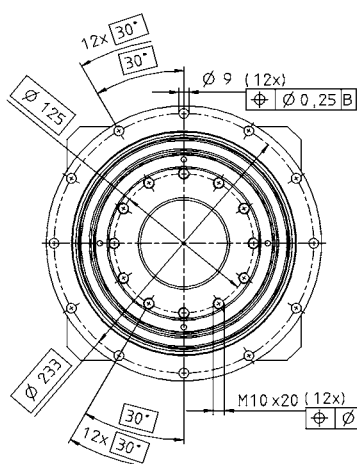
 up to 48³⁾ (M)
clamping hub
diameter

 Non-tolerated dimensions ± 1 mm

- 1) Check motor shaft fit.
- 2) Min./Max. permissible motor shaft length. Longer motor shafts are adaptable, please contact us.
- 3) The dimensions depend on the motor.
- 4) Smaller motor shaft diameter is compensated by a bushing with a minimum thickness of 1 mm.

Motor mounting according to operating manual

TP



TP+ 110 MF 2-stage

		2-stage															
Ratio ^{a)}	<i>i</i>		16	20	21	25	28	31	35	40	50	61	70	91	100		
cymex®-optimized acceleration torque (please contact us regarding the design)	T_{2Bcym}	Nm	2000	2000	–	2000	2000	–	2000	1800	1800	–	1800	–	1500		
		in.lb	17700	17700	–	17700	17700	–	17700	15930	15930	–	15930	–	13275		
Max. acceleration torque (max. 1000 cycles per hour)	T_{2B}	Nm	1600	1600	1400	1600	1600	1600	1600	1600	1600	1400	1600	1300	1400		
		in.lb	14160	14160	12390	14160	14160	14160	14160	14160	14160	12390	14160	11505	12390		
Nominal output torque (with n_n)	T_{2N}	Nm	980	980	850	1050	1050	1250	1250	850	1050	1100	900	700	800		
		in.lb	8673	8673	7523	9293	9293	11063	11063	7523	9293	9735	7965	6195	7080		
Emergency stop torque (permitted 1000 times during the service life of the gearhead)	T_{2Not}	Nm	2750	2750	2750	2750	2750	2750	2750	2750	2750	2750	2750	2750	2750		
		in.lb	24338	24338	24338	24338	24338	24338	24338	24338	24338	24338	24338	24338	24338		
Nominal input speed (with T_{2N} and 20 °C ambient temperature ^{b)})	n_{1N}	rpm	2500	2500	2500	2500	2500	2500	2500	2500	2900	3200	3200	3400	3400		
Max. input speed ^{c)}	n_{1Max}	rpm	4500	4500	4500	4500	4500	4500	4500	4500	4500	4500	4500	4500	4500		
Mean no load running torque (with $n_n=3000$ rpm and 20 °C gearhead temperature ^{c)})	T_{012}	Nm	6.9	5.6	5.5	5.0	4.1	3.9	3.7	3.0	2.7	2.5	2.4	2.2	2.2		
		in.lb	61.1	49.6	48.7	44.3	36.3	34.5	32.7	26.6	23.9	22.1	21.2	19.5	19.5		
Max. torsional backlash	j_t	arcmin	Standard ≤ 3 / Reduced ≤ 1														
Torsional rigidity ^{c)}	C_{I21}	Nm/arcmin	585	580	465	570	560	440	560	520	525	415	480	360	395		
		in.lb/arcmin	5177	5133	4115	5045	4956	3894	4956	4602	4646	3673	4248	3186	3496		
Tilting rigidity	C_{2K}	Nm/arcmin	1452														
		in.lb/arcmin	12850														
Max. axial force ^{d)}	F_{2AMax}	N	10050														
		lb _f	2261														
Max. tilting moment	M_{2KMax}	Nm	3280														
		in.lb	29028														
Efficiency at full load	η	%	94														
Service life (For calculation, see the Chapter "Information")	L_h	h	> 20000														
Weight incl. standard adapter plate	m	kg	34.0														
		lb _m	75.1														
Operating noise (with $i=100$ and $n_n=3000$ rpm no load)	L_{PA}	dB(A)	≤ 66														
Max. permitted housing temperature		°C	+90														
		F	194														
Ambient temperature		°C	-15 to +40														
		F	5 to 104														
Lubrication			Lubricated for life														
Paint			Blue RAL 5002														
Direction of rotation			Motor and gearhead same direction														
Protection class			IP 65														
Moment of inertia (relates to the drive)	G	24	J_1	kgcm ²	8.51	8.21	8.98	7.82	6.57	8.09	6.37	5.63	5.54	5.63	5.44	5.50	5.39
				10 ⁻⁴ in.lb.s ²	7.53	7.27	7.95	6.92	5.81	7.16	5.64	4.99	4.90	4.99	4.82	4.87	4.77
Clamping hub diameter [mm]	I	32	J_1	kgcm ²	11.7	11.4	12.1	11.0	9.73	11.3	9.54	8.80	8.70	8.79	8.61	8.67	8.56
				10 ⁻⁴ in.lb.s ²	10.3	10.1	10.7	9.72	8.61	9.96	8.44	7.78	7.70	7.78	7.62	7.67	7.57
	K	38	J_1	kgcm ²	12.7	12.5	13.2	12.1	10.8	12.3	10.6	9.87	9.77	9.87	9.68	9.74	9.63
				10 ⁻⁴ in.lb.s ²	11.3	11.0	11.7	10.7	9.6	10.9	9.39	8.73	8.65	8.73	8.56	8.62	8.52
M	48	J_1	kgcm ²	27.4	27.1	27.8	26.7	25.4	26.9	25.3	24.5	24.4	24.5	24.3	24.4	24.3	
			10 ⁻⁴ in.lb.s ²	24.2	24.0	24.6	23.6	22.5	23.8	22.3	21.7	21.6	21.7	21.5	21.6	21.5	

Reduced mass moments of inertia available on request.

^{a)} Other ratios available on request

^{b)} For higher ambient temperatures, please reduce input speed

^{c)} Valid for clamping hub diameter of 32 and 38 mm

^{d)} Refers to center of the output shaft or flange

View A

View B

up to 24⁴⁾ (G)
clamping hub
diameter

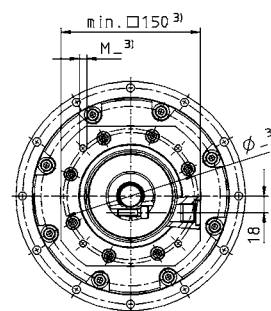
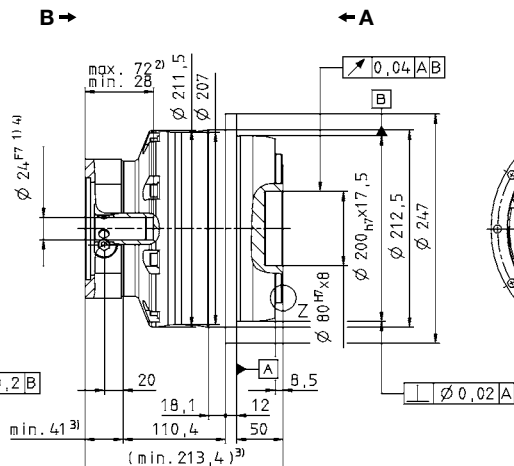
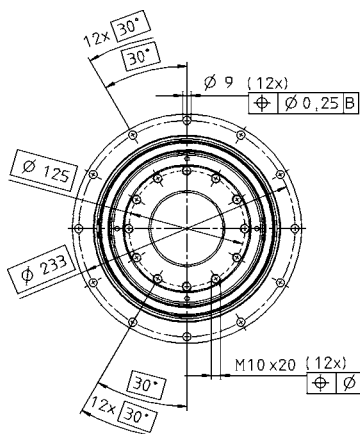

up to 32/38⁴⁾ (I/K)
clamping hub
diameter

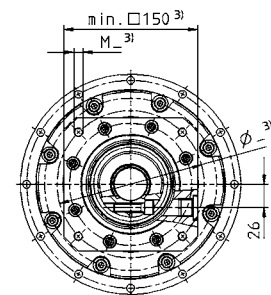
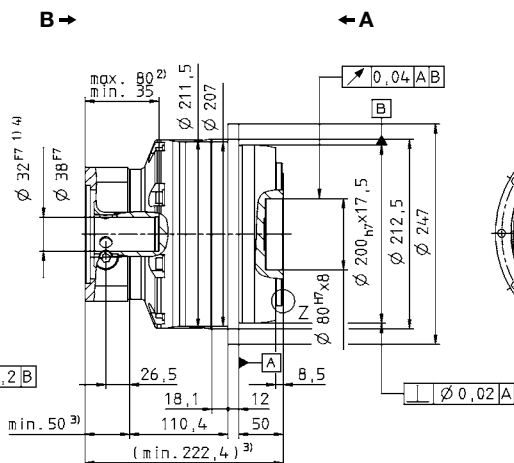
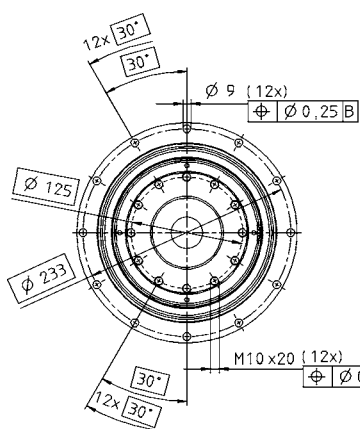

up to 48⁴⁾ (M)
clamping hub
diameter

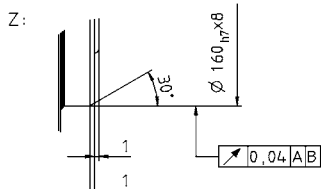
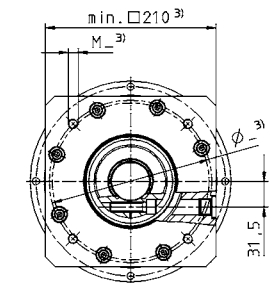
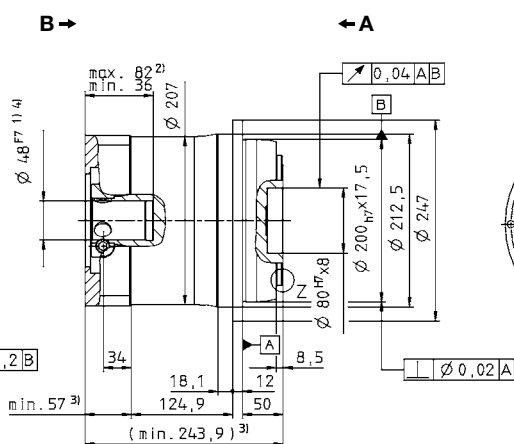
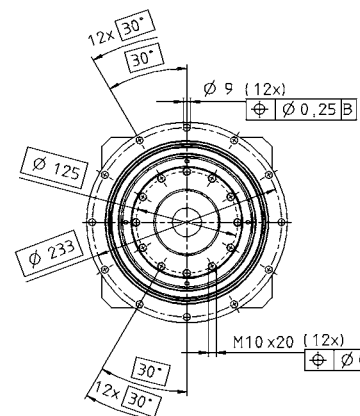

Non-tolerated dimensions ± 1 mm

- 1) Check motor shaft fit.
- 2) Min./Max. permissible motor shaft length. Longer motor shafts are adaptable, please contact us.
- 3) The dimensions depend on the motor.
- 4) Smaller motor shaft diameter is compensated by a bushing with a minimum thickness of 1 mm.

Motor mounting according to operating manual

TP



TP+ 110 MA HIGH TORQUE®

		2-stage				3-stage							
Ratio ^{a)}	<i>i</i>		22	27.5	38.5	55	66	88	110	154	220		
Max. acceleration torque (max. 1000 cycles per hour)	T_{2B}	Nm	3100	3100	3100	2000	2600	2600	2600	2600	2600		
		in.lb	27435	27435	27435	17700	23010	23010	23010	23010	23010		
Nominal output torque (with n_{1N})	T_{2N}	Nm	1570	1600	1650	1400	1600	1750	1750	1750	1750		
		in.lb	13895	14160	14603	12390	14160	15488	15488	15488	15488		
Emergency stop torque (permitted 1000 times during the service life of the gearhead)	T_{2Not}	Nm	6500	6500	6500	6500	6500	6500	6500	6500	6500		
		in.lb	57525	57525	57525	57525	57525	57525	57525	57525	57525		
Nominal input speed (with T_{2N} and 20 °C ambient temperature) ^{b)}	n_{1N}	rpm	2500	2500	2500	2500	3000	3000	3000	3000	3000		
Max. input speed	n_{1Max}	rpm	4500	4500	4500	4500	4500	4500	4500	4500	4500		
Mean no load running torque (with $n_1=3000$ rpm and 20 °C gearhead temperature) ^{c)}	T_{012}	Nm	8.0	5.5	4.5	4.0	5.0	4.0	3.5	2.0	1.8		
		in.lb	70.8	48.7	39.8	35.4	44.3	35.4	31.0	17.7	15.9		
Max. torsional backlash	j_t	arcmin	≤ 1				≤ 1						
Torsional rigidity ^{c)}	C_{t21}	Nm/arcmin	730	725	715	670	650	650	650	650	650		
		in.lb/arcmin	6461	6416	6328	5930	5753	5753	5753	5753	5753		
Tilting rigidity	C_{2K}	Nm/arcmin	1452				1452						
		in.lb/arcmin	12850				12850						
Max. axial force ^{d)}	F_{2AMax}	N	10050				10050						
		lb _f	2261				2261						
Max. tilting moment	M_{2KMax}	Nm	3280				3280						
		in.lb	29028				29028						
Efficiency at full load	η	%	94				92						
Service life (For calculation, see the Chapter "Information")	L_n	h	> 20000				> 20000						
Weight incl. standard adapter plate	<i>m</i>	kg	33.1				35.4						
		lb _m	73.2				78.2						
Operating noise (with $n_1=3000$ rpm no load)	L_{PA}	dB(A)	≤ 66				≤ 66						
Max. permitted housing temperature	°C		+90										
	F		194										
Ambient temperature	°C		-15 to +40										
	F		5 to 104										
Lubrication	Lubricated for life												
Paint	Blue RAL 5002												
Direction of rotation	Motor and gearhead same direction												
Protection class	IP 65												
Moment of inertia (relates to the drive)	K	38	J_1	kgcm ²	16.6	15.2	13.9	13.1	13.8	10.2	9.77	9.47	9.16
				10 ⁻³ in.lb.s ²	14.7	13.5	12.3	11.6	12.2	9.03	8.65	8.38	8.11
Clamping hub diameter [mm]	M	48	J_1	kgcm ²	31.4	29.9	28.7	28.0	-	-	-	-	-
				10 ⁻³ in.lb.s ²	27.8	26.5	25.4	24.8	-	-	-	-	-

Reduced mass moments of inertia available on request.

^{a)} Other ratios available on request

^{b)} For higher ambient temperatures, please reduce input speed

^{c)} Valid for clamping hub diameter of 38 mm

^{d)} Refers to center of the output shaft or flange

View A

View B

2-stage:

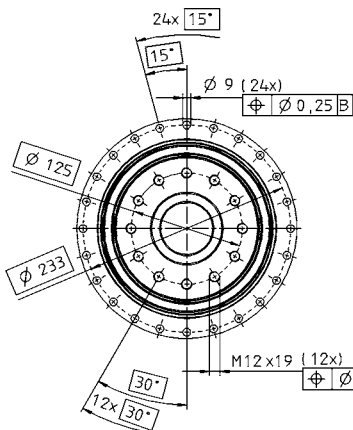

B →

← A

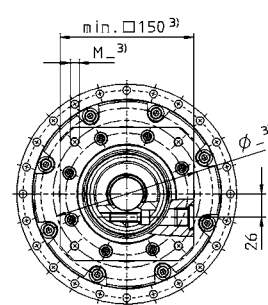
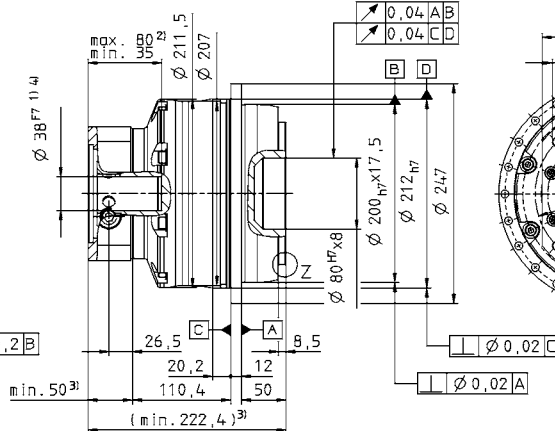

up to 38⁴⁾ (K)
clamping hub
diameter

Motor shaft diameter [mm]

up to 48⁴⁾ (M)
clamping hub
diameter

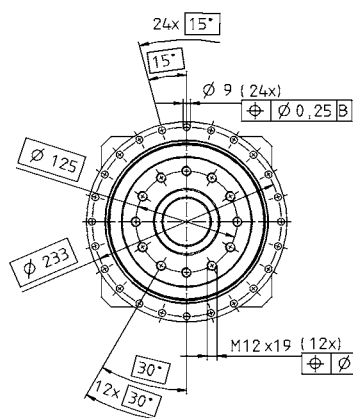

B →

← A

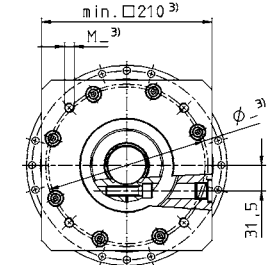
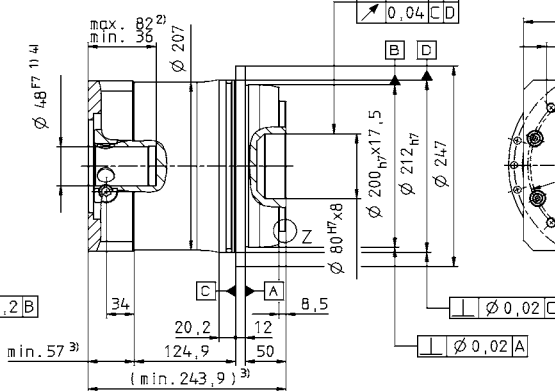

3-stage:

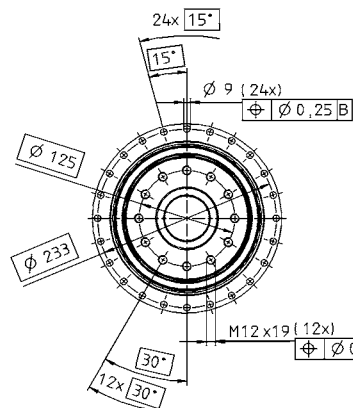

B →

← A

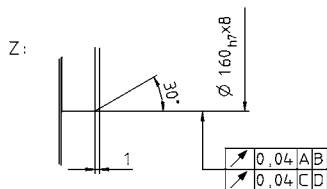
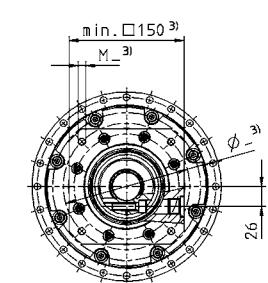
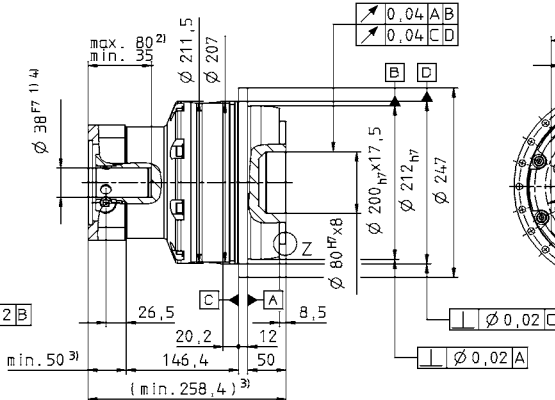

Non-tolerated dimensions ± 1 mm

- 1) Check motor shaft fit.
- 2) Min./Max. permissible motor shaft length. Longer motor shafts are adaptable, please contact us.
- 3) The dimensions depend on the motor.
- 4) Smaller motor shaft diameter is compensated by a bushing with a minimum thickness of 1 mm.

Motor mounting according to operating manual

TP



TP+ 300 MF 1/2-stage

		1-stage			2-stage												
Ratio ^{a)}	<i>i</i>	5	7	10	20	21	25	31	35	50	61	70	91	100			
Max. acceleration torque (max. 1000 cycles per hour)	T_{2B}	Nm	3500	3300	1900	3500	3400	3500	3500	3500	3000	2800	3300	2800	2800		
		in.lb	30975	29205	16815	30975	30090	30975	30975	30975	26550	24780	29205	24780	24780		
Nominal output torque (with n_{IN})	T_{2N}	Nm	2200	1800	1000	2300	2100	2400	2200	2500	1900	1600	1800	1600	1600		
		in.lb	19470	15930	8850	20355	18585	21240	19470	22125	16815	14160	15930	14160	14160		
Emergency stop torque (permitted 1000 times during the service life of the gearhead)	T_{2Not}	Nm	8750	8750	8750	8750	8750	8750	8750	8750	8750	8750	8750	8750	8750		
		in.lb	77438	77438	77438	77438	77438	77438	77438	77438	77438	77438	77438	77438	77438		
Nominal input speed (with T_{2N} and 20 °C ambient temperature) ^{b)}	n_{IN}	rpm	1000	1400	1700	2000	2000	2000	2000	2000	2300	2400	2400	2500	2500		
Max. input speed	n_{1Max}	rpm	2500	2500	2500	3500	3500	3500	3500	3500	3500	3500	3500	3500	3500		
Mean no load running torque (with $n_i=2000$ rpm and 20 °C gearhead temperature)	T_{012}	Nm	23	17	11	10	9,5	9,0	7,0	6,0	5,0	4,0	4,0	3,5	3,5		
		in.lb	204	150	97	89	84	80	62	53	44	35	35	31	31		
Max. torsional backlash	j_t	arcmin	Standard ≤ 3 / Reduced ≤ 1			Standard ≤ 3 / Reduced ≤ 2											
Torsional rigidity	C_{t21}	Nm/arcmin	1000	900	700	850	800	950	750	900	800	700	800	600	650		
		in.lb/arcmin	8850	7965	6195	7523	7080	9408	6638	7965	7080	6195	7080	5310	5753		
Tilting rigidity	C_{2K}	Nm/arcmin	5560														
		in.lb/arcmin	49206														
Max. axial force ^{c)}	F_{2AMax}	N	33000														
		lb _f	7425														
Max. tilting moment	M_{2KMax}	Nm	3900			5900											
		in.lb	34515			52215											
Efficiency at full load	η	%	95			93											
Service life (For calculation, see the Chapter "Information")	L_n	h	> 20000														
Weight incl. standard adapter plate	m	kg	60			58.5											
		lb _m	132.6			129.3											
Operating noise (with $i=10$ and $n_i=2000$ rpm without load)	L_{PA}	dB(A)	≤ 64														
Max. permitted housing temperature		°C	+90														
		F	194														
Ambient temperature		°C	-15 to +40														
		F	5 to 104														
Lubrication			Lubricated for life														
Paint			Blue RAL 5002														
Direction of rotation			Motor and gearhead same direction														
Protection class			IP 65														
Moment of inertia (relates to the drive)	M	48	J_1	kgcm ²	-	-	-	27.5	27.0	25.9	25.6	22.4	21.5	21.4	21.3	21.2	21.2
				10 ⁻³ in.lb.in ²	-	-	-	24.3	23.9	22.9	22.7	19.8	19.0	18.9	18.9	18.8	18.8
Clamping hub diameter [mm]	N	55	J_1	kgcm ²	82.6	61.2	49.5	-	-	-	-	-	-	-	-	-	-
				10 ⁻³ in.lb.in ²	73.1	54.2	43.8	-	-	-	-	-	-	-	-	-	-

Reduced mass moments of inertia available on request.

^{a)} Other ratios available on request

^{b)} For higher ambient temperatures, please reduce input speed

^{c)} Refers to center of the output shaft or flange

View A

View B

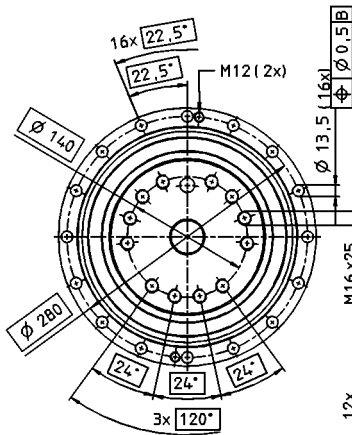
1-stage:

B →

← A

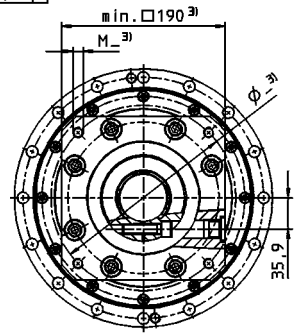
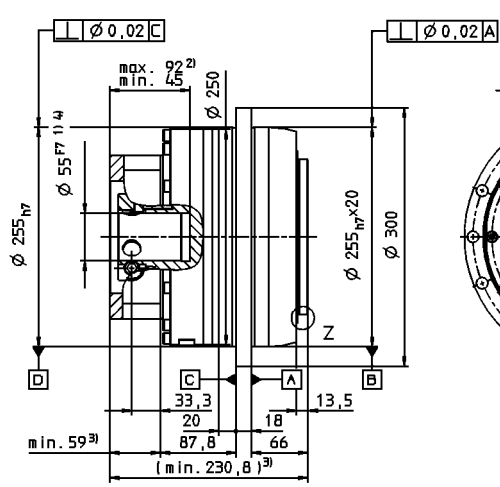
 up to 55 ⁴⁾(N)
clamping hub
diameter

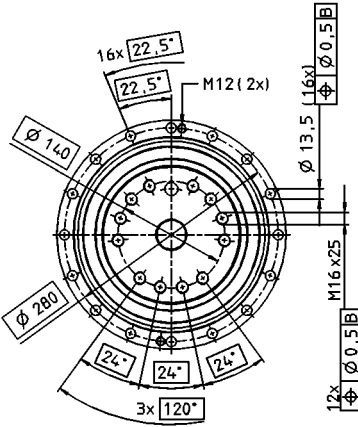
2-stage:

B →

← A

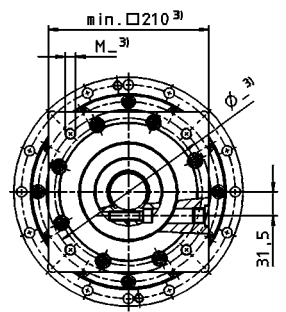
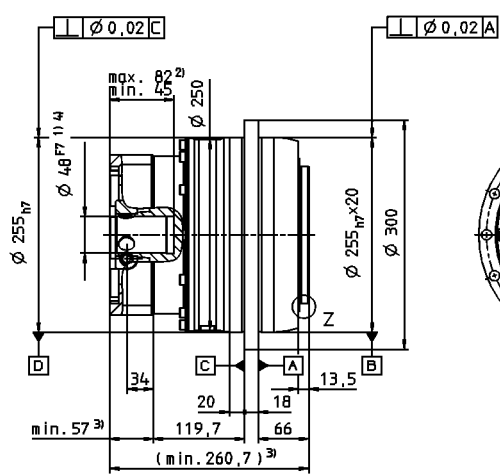
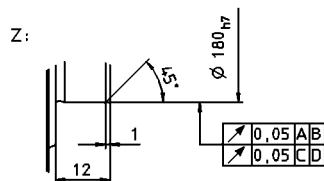
 up to 48 ⁴⁾(M)
clamping hub
diameter

Non-tolerated dimensions ±1 mm

- 1) Check motor shaft fit.
- 2) Min./Max. permissible motor shaft length. Longer motor shafts are adaptable, please contact us.
- 3) The dimensions depend on the motor.
- 4) Smaller motor shaft diameter is compensated by a bushing with a minimum thickness of 1 mm.

Motor mounting according to operating manual

TP*



TP+ 300 MA HIGH TORQUE®

				1-stage	2-stage				3-stage					
Ratio ^{a)}	<i>i</i>		5.5	22	27.5	38.5	55	66	88	110	154	220		
Max. acceleration torque (max. 1000 cycles per hour)	T_{2B}	Nm	4600	5500	5500	5500	3900	5500	5500	5500	5500	5500		
		in.lb	40714	48679	48679	48679	34518	48679	48679	48679	48679	48679		
Nominal output torque (with n_{1N})	T_{2N}	Nm	2200	3500	3500	3500	2500	3500	3500	3500	3500	3500		
		in.lb	19472	30978	30978	30978	22127	30978	30978	30978	30978	30978		
Emergency stop torque (permitted 1000 times during the service life of the gearhead)	T_{2Not}	Nm	8750	13250	13250	13250	13250	13250	13250	13250	13250	13250		
		in.lb	77445	117273	117273	117273	117273	117273	117273	117273	117273	117273		
Nominal input speed (with T_{2N} and 20 °C ambient temperature) ^{b)}	n_{1N}	rpm	1000	2000	2000	2000	2000	2000	2000	2000	2000	2000		
Max. input speed	n_{1Max}	rpm	2500	3500	3500	3500	3500	3500	3500	3500	3500	3500		
Mean no load running torque (with $n_1=2000$ rpm and 20 °C gearhead temperature)	T_{012}	Nm	22	12	10	9,0	7,0	6,5	4,5	4,0	3,0	2,0		
		in.lb	195	106	89	80	62	58	40	35	27	18		
Max. torsional backlash	j_t	arcmin	Standard ≤ 2 / Reduced ≤ 1		Standard ≤ 3 / Reduced ≤ 1.5									
Torsional rigidity	C_{t21}	Nm/arcmin	1400	1200	-	-	-	-	-	1200	-	-		
		in.lb/arcmin	12391	10621	-	-	-	-	-	10621	-	-		
Tilting rigidity	C_{2K}	Nm/arcmin	5560											
		in.lb/arcmin	49210											
Max. axial force ^{c)}	F_{2AMax}	N	33000											
		lb _f	7425											
Max. tilting moment	M_{2KMax}	Nm	3900	6500										
		in.lb	34518	57530										
Efficiency at full load	η	%	95	93										
Service life (For calculation, see "Technical Basics")	L_h	h	> 20000											
Weight incl. standard adapter plate	<i>m</i>	kg	55	64				67						
		lb _m	121.25	141.1				147.7						
Operating noise (with $n_1=2000$ rpm no load)	L_{PA}	dB(A)	≤ 68	≤ 67				≤ 66						
Max. permitted housing temperature	°C		+90											
	F		194											
Ambient temperature	°C		-15 to +40											
	F		5 to 104											
Lubrication	Lubricated for life													
Paint	Blue RAL 5002													
Direction of rotation	Motor and gearhead same direction													
Protection class	IP 65													
Moment of inertia (relates to the drive)	K	38	J_1	kgcm ²	-	-	-	-	-	16.6	12.9	11.6	10.3	9.50
				in.lb.s ²	-	-	-	-	-	0.0147	0.0114	0.0103	0.0091	0.0084
Clamping hub diameter [mm]	M	48	J_1	kgcm ²	-	30.8	27.6	24.9	23.0	-	-	-	-	-
				in.lb.s ²	-	0.0273	0.0244	0.0220	0.0204	-	-	-	-	-
	N	55	J_1	kgcm ²	129	-	-	-	-	-	-	-	-	-
				in.lb.s ²	0.1142	-	-	-	-	-	-	-	-	-

Reduced mass moments of inertia available on request.

^{a)} Other ratios available on request

^{b)} For higher ambient temperatures, please reduce input speed

^{c)} Refers to center of the output shaft or flange

1-stage:

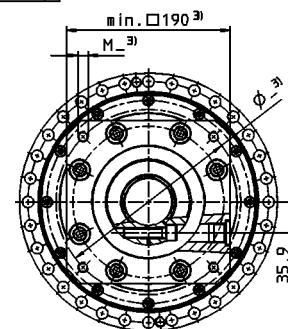
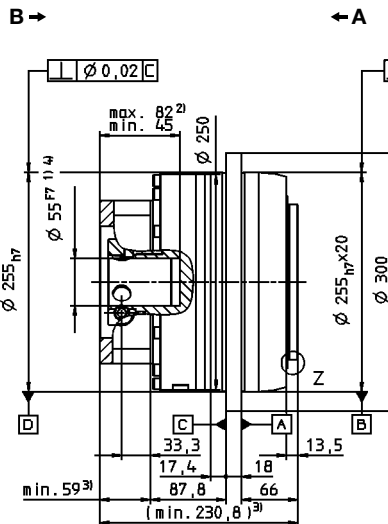
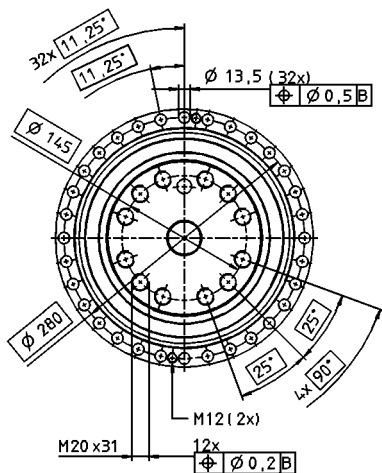

up to 55⁴⁾ (N)
clamping hub
diameter

2-stage:

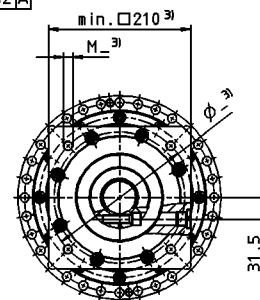
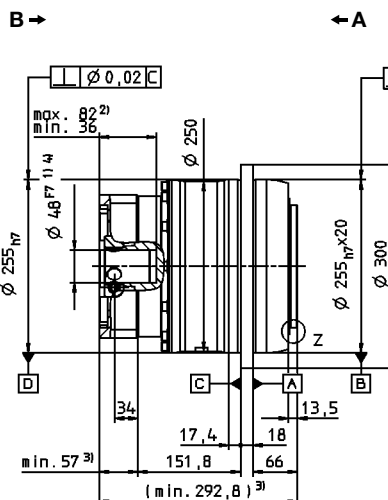
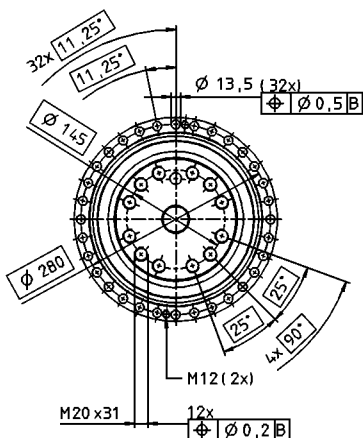

up to 48⁴⁾ (M)
clamping hub
diameter

3-stage:

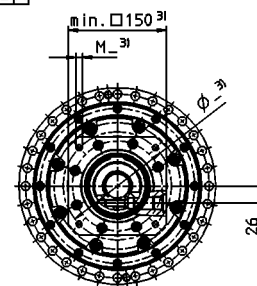
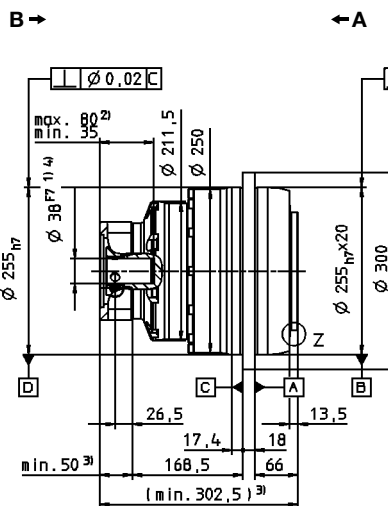
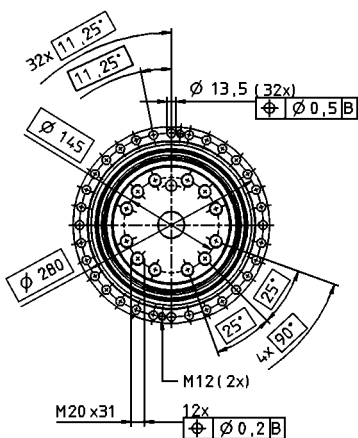

up to 38⁴⁾ (K)
clamping hub
diameter

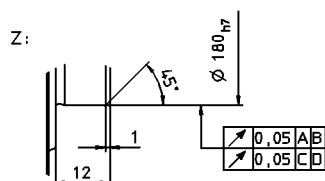

Non-tolerated dimensions ± 1 mm

- 1) Check motor shaft fit.
- 2) Min./Max. permissible motor shaft length. Longer motor shafts are adaptable, please contact us.
- 3) The dimensions depend on the motor.
- 4) Smaller motor shaft diameter is compensated by a bushing with a minimum thickness of 1 mm.

Motor mounting according to operating manual

TP:



Motor shaft diameter [mm]

TP+ 500 MF 1/2-stage

		1-stage			2-stage												
Ratio ^{a)}	<i>i</i>	5	7	10	20	21	25	31	35	50	61	70	91	100			
Max. acceleration torque (max. 1000 cycles per hour)	T_{2B}	Nm	6000	5000	3400	6000	5000	6000	6000	6000	4500	4800	5000	4800	4800		
		in.lb	53100	44250	30090	53100	44250	53100	53100	53100	39825	42480	44250	42480	42480		
Nominal output torque (with n_{1N})	T_{2N}	Nm	3250	2800	1700	3350	3200	3800	3700	3800	2900	2900	2800	2900	2900		
		in.lb	28763	24780	15045	29648	28320	33630	32745	33630	25665	25665	24780	25665	25665		
Emergency stop torque (permitted 1000 times during the service life of the gearhead)	T_{2Not}	Nm	15000	15000	15000	15000	15000	15000	15000	15000	15000	15000	15000	15000	15000		
		in.lb	132750	132750	132750	132750	132750	132750	132750	132750	132750	132750	132750	132750	132750		
Nominal input speed (with T_{2N} and 20 °C ambient temperature) ^{b)}	n_{1N}	rpm	900	1300	1500	1500	1500	1500	1500	2000	2100	2100	2200	2200			
Max. input speed	n_{1Max}	rpm	2500	2500	2500	3500	3500	3500	3500	3500	3500	3500	3500	3500			
Mean no load running torque (with $n_1=2000$ rpm and 20 °C gearhead temperature)	T_{012}	Nm	30	22	14	13	12	10	8,0	7,0	6,0	5,0	5,0	4,5	4,5		
		in.lb	266	195	124	115	106	89	71	62	53	44	44	40	40		
Max. torsional backlash	j_t	arcmin	Standard ≤ 3 / Reduced ≤ 1			Standard ≤ 3 / Reduced ≤ 2											
Torsional rigidity	C_{21}	Nm/arcmin	1450	1300	1100	1400	1200	1450	1200	1400	1300	1100	1250	950	1050		
		in.lb/arcmin	12833	11505	9735	12390	10620	12833	10620	12390	11505	9735	11063	8401	9293		
Tilting rigidity	C_{2K}	Nm/arcmin	9480														
		in.lb/arcmin	83898														
Max. axial force ^{c)}	F_{2AMax}	N	50000														
		lb _f	11250														
Max. tilting moment	M_{2KMax}	Nm	5500			8800											
		in.lb	48675			77880											
Efficiency at full load	η	%	95			93											
Service life (For calculation, see the Chapter "Information")	L_n	h	> 20000														
Weight incl. standard adapter plate	<i>m</i>	kg	82			77.5											
		lb _m	181.2			171.3											
Operating noise (with $i=10$ and $n_1=2000$ rpm no load)	L_{PA}	dB(A)	≤ 66														
Max. permitted housing temperature		°C	+90														
		F	194														
Ambient temperature		°C	-15 to +40														
		F	5 to 104														
Lubrication			Lubricated for life														
Paint			Blue RAL 5002														
Direction of rotation			Motor and gearhead same direction														
Protection class			IP 65														
Moment of inertia (relates to the drive)	M	48	J_1	kgcm ²	-	-	-	32.3	37.6	31.1	32.8	25.1	23.2	23.6	23.2	23.0	22.7
				10 ⁻³ in.lb.in ²	-	-	-	28.6	33.3	27.5	29.0	22.2	20.5	20.9	20.5	20.4	20.1
Clamping hub diameter [mm]	O	60	J_1	kgcm ²	175.5	137.0	115.8	-	-	-	-	-	-	-	-	-	-
				10 ⁻³ in.lb.in ²	155.3	121.2	102.5	-	-	-	-	-	-	-	-	-	-

Reduced mass moments of inertia available on request.

^{a)} Other ratios available on request

^{b)} For higher ambient temperatures, please reduce input speed

^{c)} Refers to center of the output shaft or flange

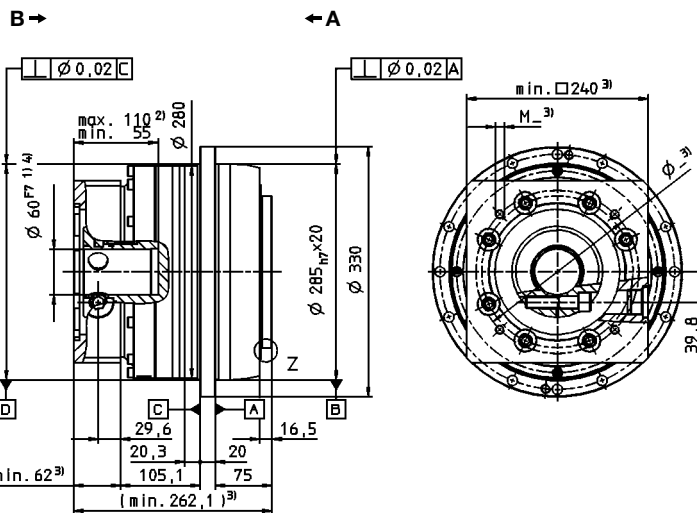
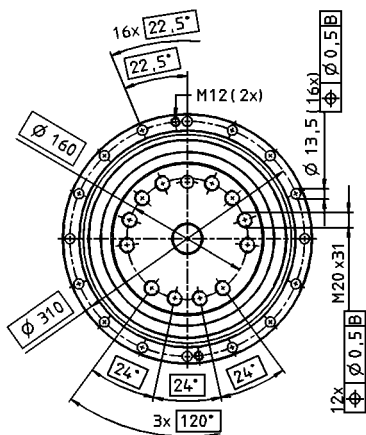
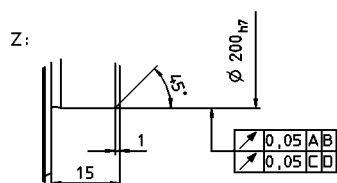
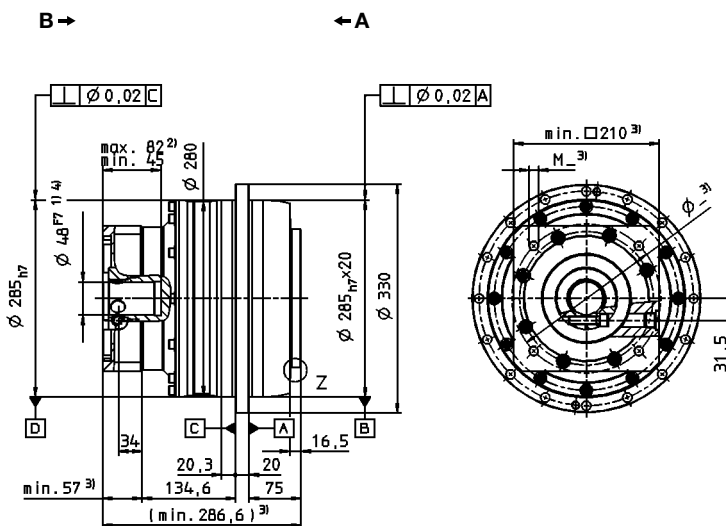
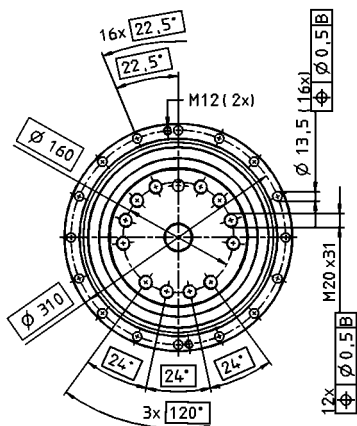
1-stage:

2-stage:

 Non-tolerated dimensions ± 1 mm

- 1) Check motor shaft fit.
- 2) Min./Max. permissible motor shaft length. Longer motor shafts are adaptable, please contact us.
- 3) The dimensions depend on the motor.
- 4) Smaller motor shaft diameter is compensated by a bushing with a minimum thickness of 1 mm.

Motor mounting according to operating manual



TP+ 500 MA HIGH TORQUE®

				1-stage	2-stage				3-stage					
Ratio ^{a)}	<i>i</i>		5.5	22	27.5	38.5	55	66	88	110	154	220		
Max. acceleration torque (max. 1000 cycles per hour)	T_{2B}	Nm	8000	10000	10000	10000	7200	10000	10000	10000	10000	10000		
		in.lb	70806	88508	88508	88508	63726	88508	88508	88508	88508	88508		
Nominal output torque (with n_{in})	T_{2N}	Nm	3500	6000	4600	4600	4700	6000	6000	6000	6000	6000		
		in.lb	30978	53105	40714	40714	41599	53105	53105	53105	53105	53105		
Emergency stop torque (permitted 1000 times during the service life of the gearhead)	T_{2Not}	Nm	15000	25000	25000	25000	25000	25000	25000	25000	25000	25000		
		in.lb	132762	221270	221270	221270	221270	221270	221270	221270	221270	221270		
Nominal input speed (with T_{2N} and 20 °C ambient temperature) ^{b)}	n_{iN}	rpm	900	1500	1500	1500	1500	1500	1500	1500	1500	1500		
Max. input speed	n_{iMax}	rpm	2500	3500	3500	3500	3500	3500	3500	3500	3500	3500		
Mean no load running torque (with $n_i=2000$ rpm and 20 °C gearhead temperature)	T_{012}	Nm	28	18	14	12	9.0	8.5	6.5	6.0	5.0	4.0		
		in.lb	248	159.3	124	106	80	75	58	53	44	35		
Max. torsional backlash	j_t	arcmin	Standard ≤ 2 / Reduced ≤ 1		Standard ≤ 3 / Reduced ≤ 1.5									
Torsional rigidity	C_{21}	Nm/arcmin	1650	2000	-	-	-	-	-	1500	-	1800		
		in.lb/arcmin	14603	17700	-	-	-	-	-	13275	-	15930		
Tilting rigidity	C_{2K}	Nm/arcmin	9480											
		in.lb/arcmin	83906											
Max. axial force ^{c)}	F_{2AMax}	N	50000											
		lb _f	11250											
Max. tilting moment	M_{2KMax}	Nm	6600	9500										
		in.lb	58415	84083										
Efficiency at full load	η	%	95	93										
Service life (For calculation, see "Technical Basics")	L_h	h	> 20000											
Weight incl. standard adapter plate	<i>m</i>	kg	80				89							
		lb _m	176.4				196.2							
Operating noise (with $n_i=2000$ rpm no load)	L_{PA}	dB(A)	≤ 68				≤ 67							
Max. permitted housing temperature	°C		+90											
	F		194											
Ambient temperature	°C		-15 to +40											
	F		5 to 104											
Lubrication	Lubricated for life													
Paint	Blue RAL 5002													
Direction of rotation	Motor and gearhead same direction													
Protection class	IP 65													
Moment of inertia (relates to the drive)	M	48	J_1	kgcm ²	-	43.8	36.9	30.5	27.0	32.7	28.3	26.7	25.2	24.4
				in.lb.s ²	-	0.0388	0.0327	0.0270	0.0239	0.0289	0.0250	0.0236	0.0223	0.0216
Clamping hub diameter [mm]	O	60	J_1	kgcm ²	175	-	-	-	-	-	-	-	-	-
				in.lb.s ²	0.1549	-	-	-	-	-	-	-	-	-

Reduced mass moments of inertia available on request.

^{a)} Other ratios available on request

^{b)} For higher ambient temperatures, please reduce input speed

^{c)} Refers to center of the output shaft or flange

1-stage:

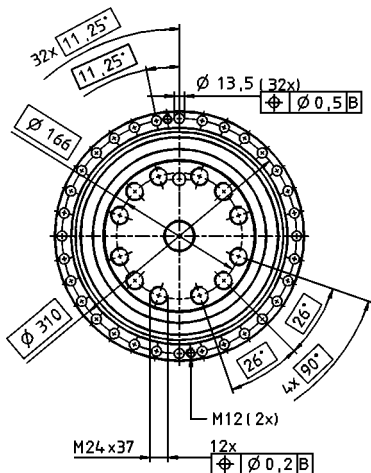

B →

← A

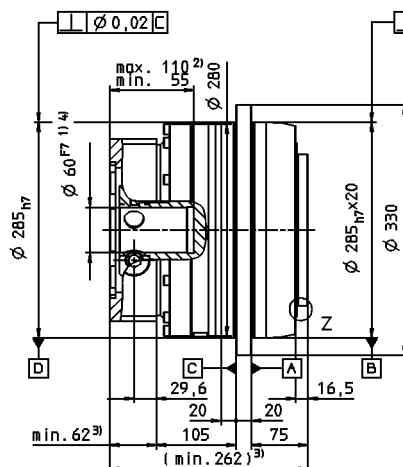

2-stage:

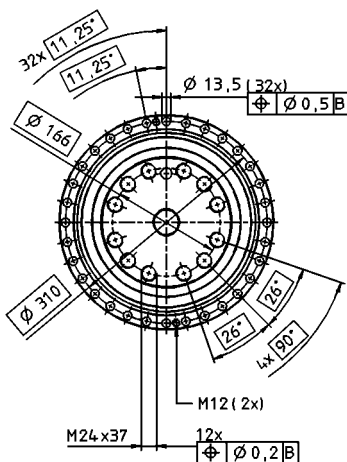

B →

← A

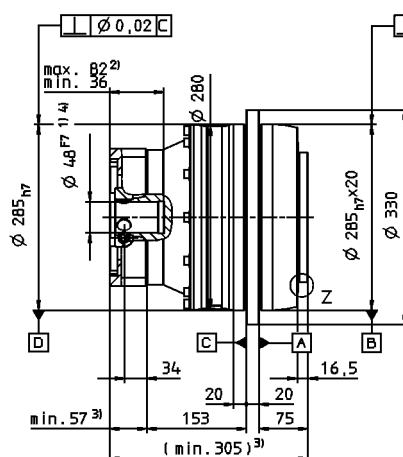

3-stage:

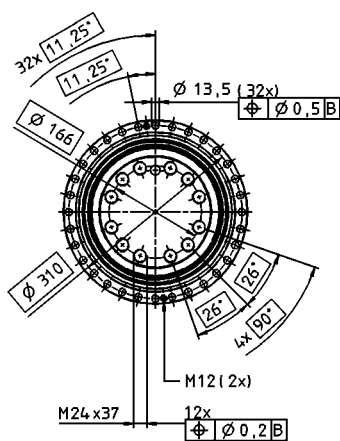

B →

← A

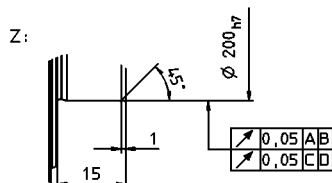
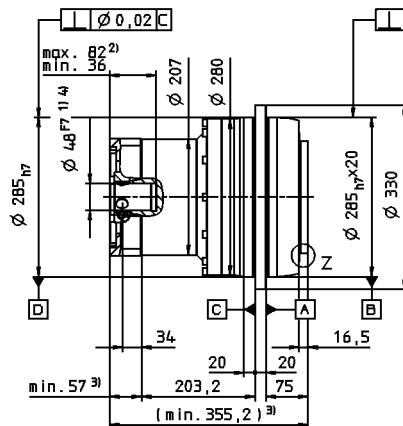

Non-tolerated dimensions \pm 1 mm

- 1) Check motor shaft fit.
- 2) Min./Max. permissible motor shaft length. Longer motor shafts are adaptable, please contact us.
- 3) The dimensions depend on the motor.
- 4) Smaller motor shaft diameter is compensated by a bushing with a minimum thickness of 1 mm.

Motor mounting according to operating manual

up to 60⁴⁾ (O)
clamping hub
diameter

Motor shaft diameter [mm]
up to 48⁴⁾ (M)
clamping hub
diameter

up to 48⁴⁾ (M)
clamping hub
diameter

TP



SP+ MF – The new generation

The classic all-rounder among planetary gearheads

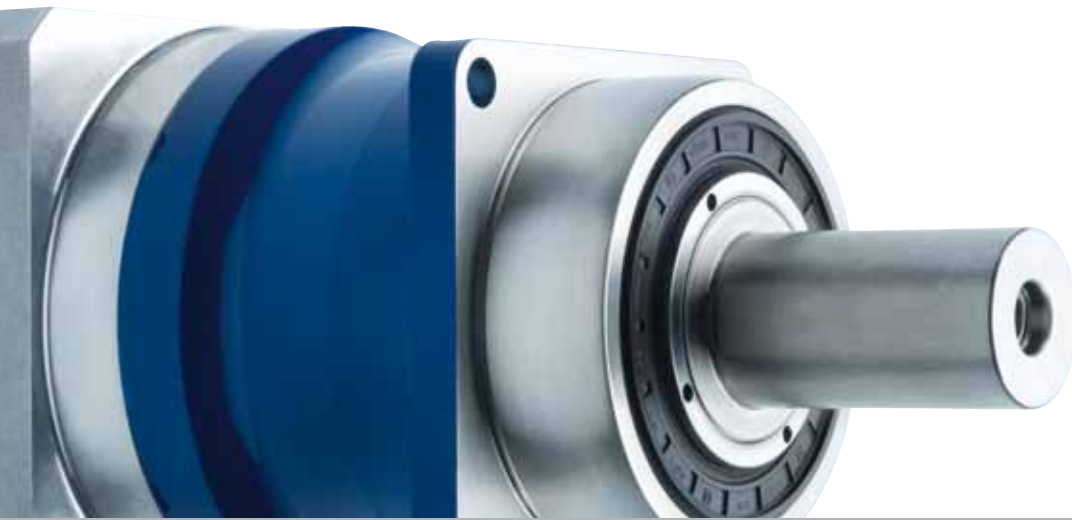

MF version

Designed for:

- Cyclic applications
- Reverse operation
- Highly dynamic applications
- Greater positioning accuracy

SP+

Specifications \ Version	SP+ MF		
	+	++	+++
Positioning accuracy			██████████
Rigidity		██████████	
Smooth-running			██████████
Speed capacity			██████████
Power density		██████████	
Max. axial/radial forces		██████████	



Shaft mounted, mounted via shrink disc

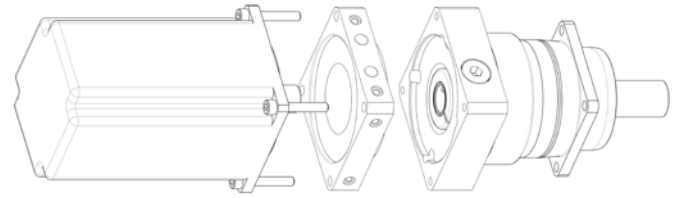

Intermediate flange for cooling system



Shrink disc



See our website and our separate flyer for more information about our washdown solutions



Couplings



Rack / Pinion

Options

- Output shaft with key / involute
- NEW: Shaft mounted, mounted via shrink disc
- Washdown version
- ATEX version 
- Food-grade grease 
- Version with optimized mass moment of inertia

Accessories

- Rack / Pinion (see page 310)
- Shrink disc (see page 342)
- Couplings (see page 342)
- Intermediate flange for cooling system

SP+ 060 MF 1-stage

				1-stage					
Ratio ^{a)}		<i>i</i>		3	4	5	7	10	
cymex [®] -optimized acceleration torque (please contact us regarding the design)	T_{2Bcym}	Nm		-	58	60	54	-	
					in.lb	513	531		478
Max. acceleration torque (max. 1000 cycles per hour)	T_{2B}	Nm		30	42	42	42	32	
				in.lb	266	372	372	372	283
Nominal output torque (with n_N)	T_{2N}	Nm		17	26	26	26	17	
				in.lb	150	230	230	230	150
Emergency stop torque (permitted 1000 times during the service life of the gearhead)	T_{2Not}	Nm		80	100	100	100	80	
				in.lb	708	885	885	885	708
Nominal input speed (with T_{2N} and 20°C ambient temperature) ^{b)}	n_{1N}	rpm		3300	3300	3300	4000	4000	
Max. input speed	n_{1max}	rpm		6000	6000	6000	6000	6000	
Mean no load running torque (with $n_i=3000$ rpm and 20°C gearhead temperature) ^{c)}	T_{012}	Nm		0.9	0.7	0.6	0.4	0.3	
				in.lb	8.0	6.2	5.3	3.5	2.7
Max. torsional backlash	j_t	arcmin		Standard ≤ 4 / Reduced ≤ 2					
Torsional rigidity	C_{I21}	Nm/ arcmin		3.5					
				in.lb/ arcmin	31				
Max. axial force ^{d)}	F_{2AMax}	N		2400					
				lb _f	540				
Max. radial force ^{d)}	F_{2RMax}	N		2800					
				lb _f	630				
Max. tilting torque	M_{2KMax}	Nm		152					
				in.lb	1345				
Efficiency at full load	η	%		97					
Service life (For calculation, see the Chapter "Information")	L_h	h		> 20000					
Weight incl. standard adapter plate	m	kg		1.9					
				lb _m	4.2				
Operating noise (with $i=10$ and $n_i=3000$ rpm no load)	L_{PA}	dB(A)		≤ 58					
Max. permitted housing temperature		°C		+90					
				F	194				
Ambient temperature		°C		-15 to +40					
				F	5 to 104				
Lubrication			Lubricated for life						
Paint			Blue RAL 5002						
Direction of rotation			Motor and gearhead same direction						
Protection class			IP 65						
Moment of inertia (relates to the drive)	B	11	J_1	kgcm ²	0.21	0.15	0.12	0.10	0.09
				10 ³ in.lb.s ²	0.18	0.13	0.11	0.09	0.08
Clamping hub diameter [mm]	C	14	J_1	kgcm ²	0.28	0.22	0.20	0.18	0.17
				10 ³ in.lb.s ²	0.25	0.20	0.17	0.16	0.15
	E	19	J_1	kgcm ²	0.61	0.55	0.52	0.50	0.49
				10 ³ in.lb.s ²	0.54	0.48	0.46	0.44	0.43

Reduced mass moments of inertia available on request.

^{a)} Other ratios available on request

^{b)} For higher ambient temperatures, please reduce input speed

^{c)} Valid for clamping hub diameter of 14 mm

^{d)} Refers to center of the output shaft or flange

View A

View B

up to 11⁴⁾ (B)
clamping hub diameter

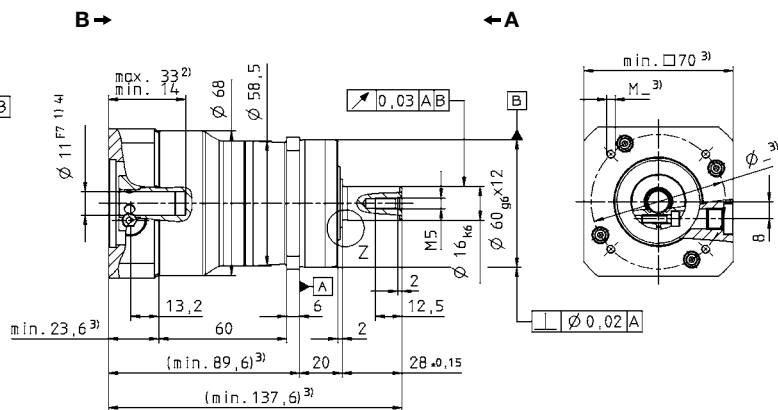
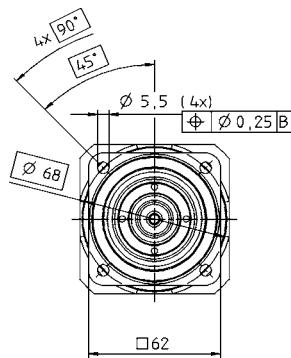

SP:



Motor shaft diameter [mm]

up to 14⁴⁾ (C)
clamping hub diameter¹⁾

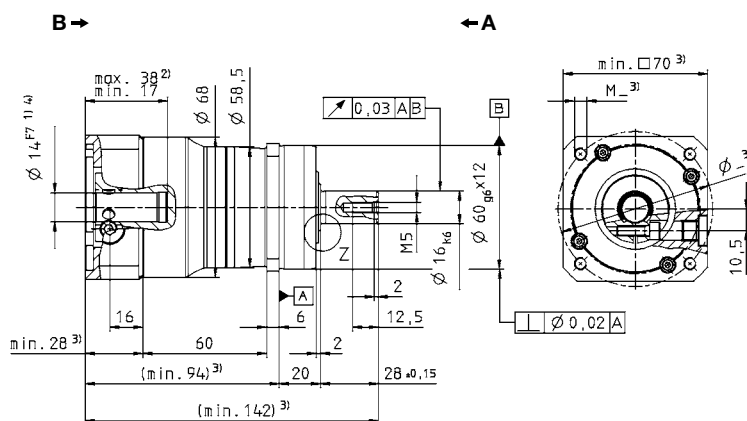
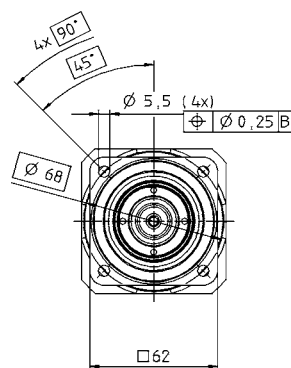

up to 19⁴⁾ (E)
clamping hub diameter

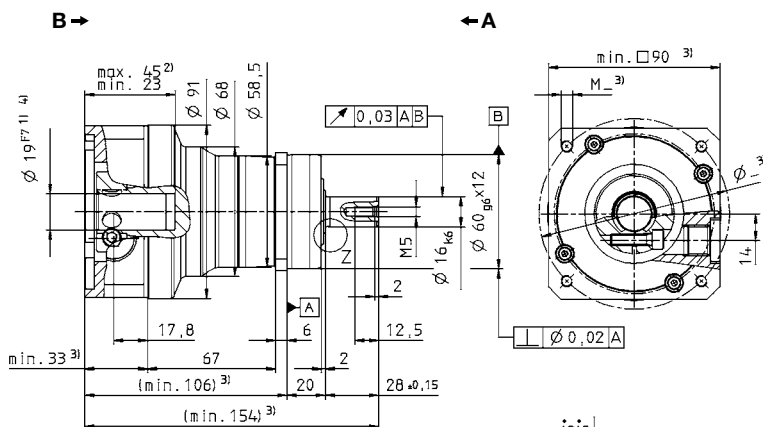
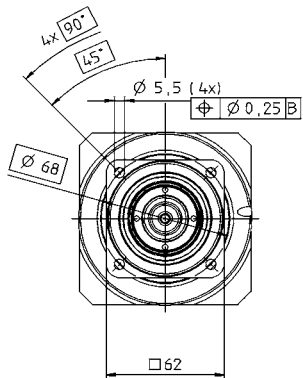

Alternatives: Output shaft variants

Keywayed output shaft in mm
E = key as per DIN 6885, sheet 1, form A

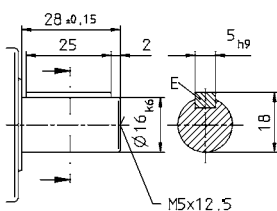

Involute gearing DIN 5480 in mm
X = W 16 x 0.8 x 30 x 18 x 6m, DIN 5480

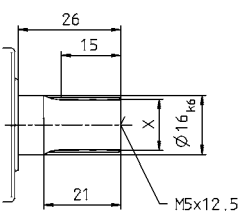

Shaft mounted
Mounted via shrink disc

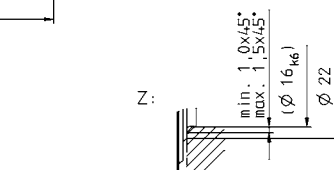
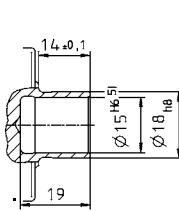

Non-tolerated dimensions ± 1 mm

- 1) Check motor shaft fit.
- 2) Min./Max. permissible motor shaft length.
Longer motor shafts are adaptable, please contact us.
- 3) The dimensions depend on the motor.
- 4) Smaller motor shaft diameter is compensated by a bushing with a minimum thickness of 1 mm.
- 5) Tolerance h6 for mounted shaft.

⚠ Motor mounting according to operating manual

SP+ 060 MF 2-stage

				2-stage									
Ratio ^{a)}	<i>i</i>			16	20	25	28	35	40	50	70	100	
cymex®-optimized acceleration torque (please contact us regarding the design)	T_{2Bcym}	Nm		58	58	60	58	60	58	60	54	–	
			in.lb	513	513	531	513	531	513	531	478	–	
Max. acceleration torque (max. 1000 cycles per hour)	T_{2B}	Nm		42	42	42	42	42	42	42	42	32	
			in.lb	372	372	372	372	372	372	372	372	283	
Nominal output torque (with n_{2N})	T_{2N}	Nm		26	26	26	26	26	26	26	26	17	
			in.lb	230	230	230	230	230	230	230	230	150	
Emergency stop torque (permitted 1000 times during the service life of the gearhead)	T_{2Not}	Nm		100	100	100	100	100	100	100	100	80	
			in.lb	885	885	885	885	885	885	885	885	708	
Nominal input speed (with T_{2N} and 20°C ambient temperature) ^{b)}	n_{1N}	rpm		4400	4400	4400	4400	4400	4400	4800	5500	5500	
Max. input speed	n_{1max}	rpm		6000	6000	6000	6000	6000	6000	6000	6000	6000	
Mean no load running torque (with $n_1=3000$ rpm and 20°C gearhead temperature) ^{c)}	T_{012}	Nm		0.5	0.4	0.4	0.3	0.3	0.3	0.3	0.3	0.2	
			in.lb	4.4	3.5	3.5	2.7	2.7	2.7	2.7	2.7	1.8	
Max. torsional backlash	j_t	arcmin		Standard ≤ 6 / Reduced ≤ 4									
Torsional rigidity	C_{I21}	Nm/ arcmin		3.5									
			in.lb/ arcmin	31.0									
Max. axial force ^{d)}	F_{2AMax}	N		2400									
			lb _f	540									
Max. radial force ^{d)}	F_{2RMMax}	N		2800									
			lb _f	630									
Max. tilting moment	M_{2KMax}	Nm		152									
			in.lb	1345									
Efficiency at full load	η	%		94									
Service life (For calculation, see the Chapter "Information")	L_h	h		> 20000									
Weight incl. standard adapter plate	m	kg		2.0									
			lb _m	4.4									
Operating noise (with $i=100$ and $n_1=3000$ rpm no load)	L_{PA}	dB(A)		≤ 58									
Max. permitted housing temperature		°C		+90									
			F	194									
Ambient temperature		°C		-15 to +40									
			F	5 to 104									
Lubrication				Lubricated for life									
Paint				Blue RAL 5002									
Direction of rotation				Motor and gearhead same direction									
Protection class				IP 65									
Moment of inertia (relates to the drive)	B	11	J_1	kgcm ²	0.077	0.069	0.068	0.061	0.061	0.057	0.057	0.056	0.056
				10 ⁻³ in.lb.s ²	0.068	0.061	0.060	0.054	0.054	0.050	0.050	0.050	0.050
Clamping hub diameter [mm]	C	14	J_1	kgcm ²	0.17	0.16	0.16	0.16	0.16	0.15	0.15	0.15	0.15
				10 ⁻³ in.lb.s ²	0.15	0.15	0.14	0.14	0.14	0.14	0.13	0.13	0.13

Reduced mass moments of inertia available on request.

^{a)} Other ratios available on request

^{b)} For higher ambient temperatures, please reduce input speed

^{c)} Valid for clamping hub diameter of 11 mm

^{d)} Refers to center of the output shaft or flange

View A

View B

Motor shaft diameter [mm]

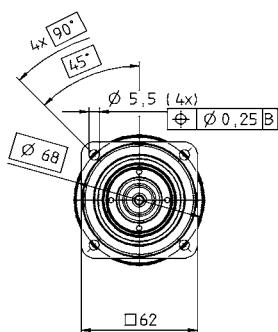
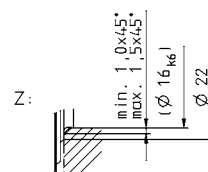
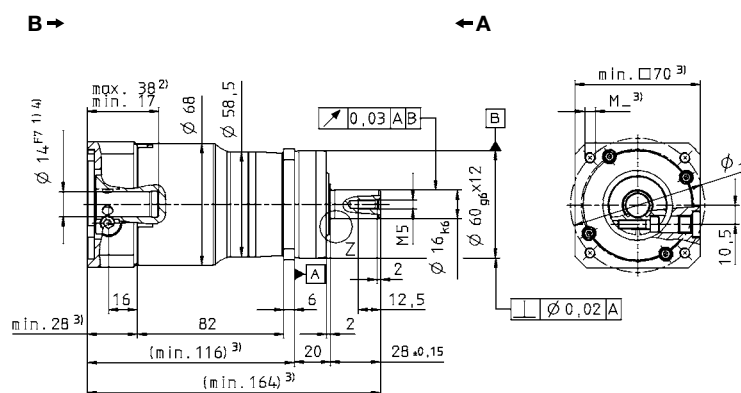
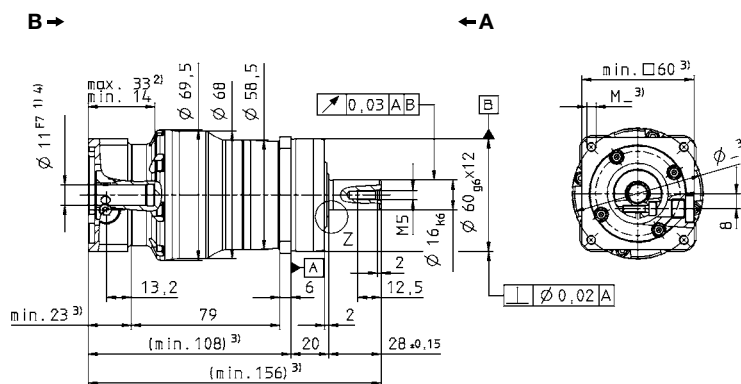
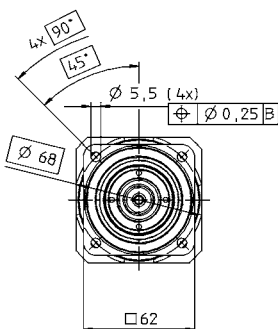
 up to 11⁴⁾(B)
clamping hub diameter

 up to 14⁴⁾(C)
clamping hub diameter

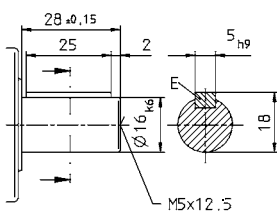
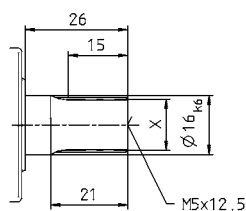
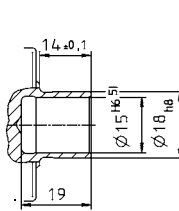
Alternatives: Output shaft variants

 Keywayed output shaft in mm
E = key as per DIN 6885, sheet 1, form A

 Involute gearing DIN 5480 in mm
X = W 16 x 0.8 x 30 x 18 x 6m, DIN 5480

 Shaft mounted
Mounted via shrink disc

Non-tolerated dimensions ± 1 mm

- 1) Check motor shaft fit.
- 2) Min./Max. permissible motor shaft length.
Longer motor shafts are adaptable, please contact us.
- 3) The dimensions depend on the motor.
- 4) Smaller motor shaft diameter is compensated by a bushing with a minimum thickness of 1 mm.
- 5) Tolerance h6 for mounted shaft.

Motor mounting according to operating manual

SP



SP+ 075 MF 1-stage

				1-stage					
Ratio ^{a)}		<i>i</i>		3	4	5	7	10	
cymex [®] -optimized acceleration torque (please contact us regarding the design)	T_{2Bcym}		Nm	–	142	160	142	100	
			in.lb	–	1254	1416	1254	883	
Max. acceleration torque (max. 1000 cycles per hour)	T_{2B}		Nm	85	110	110	110	95	
			in.lb	752	974	974	974	841	
Nominal output torque (with n_{2N})	T_{2N}		Nm	47	75	75	75	52	
			in.lb	416	664	664	664	460	
Emergency stop torque (permitted 1000 times during the service life of the gearhead)	T_{2Not}		Nm	200	250	250	250	200	
			in.lb	1770	2213	2213	2213	1770	
Nominal input speed (with T_{2N} and 20°C ambient temperature) ^{b)}	n_{1N}	rpm		2900	2900	2900	3100	3100	
Max. input speed	n_{1Max}	rpm		6000	6000	6000	6000	6000	
Mean no load running torque (with $n_1=3000$ rpm and 20°C gearhead temperature) ^{c)}	T_{012}		Nm	1.8	1.4	1.1	0.8	0.6	
			in.lb	15.9	12.4	9.7	7.1	5.3	
Max. torsional backlash	j_t	arcmin	Standard ≤ 4 / Reduced ≤ 2						
Torsional rigidity	C_{I21}		Nm/ arcmin	10					
			in.lb/ arcmin	89					
Max. axial force ^{d)}	F_{2AMax}		N	3350					
			lb _f	754					
Max. radial force ^{d)}	F_{2RMax}		N	4200					
			lb _f	945					
Max. tilting moment	M_{2KMax}		Nm	236					
			in.lb	2089					
Efficiency at full load	η	%	97						
Service life (For calculation, see the Chapter "Information")	L_h	h	> 20000						
Weight incl. standard adapter plate	m		kg	3.9					
			lb _m	8.6					
Operating noise (with $i=10$ and $n_1=3000$ rpm no load)	L_{PA}	dB(A)	≤ 59						
Max. permitted housing temperature			°C	+90					
			F	194					
Ambient temperature			°C	-15 to +40					
			F	5 to 104					
Lubrication	Lubricated for life								
Paint	Blue RAL 5002								
Direction of rotation	Motor and gearhead same direction								
Protection class	IP 65								
Moment of inertia (relates to the drive)	C	14	J_1	kgcm ²	0.86	0.61	0.51	0.42	0.38
				10 ⁻³ in.lb.s ²	0.76	0.54	0.46	0.37	0.33
Clamping hub diameter [mm]	E	19	J_1	kgcm ²	1.03	0.78	0.68	0.59	0.54
				10 ⁻³ in.lb.s ²	0.91	0.69	0.60	0.52	0.48
	G	24	J_1	kgcm ²	2.40	2.15	2.05	1.96	1.91
				10 ⁻³ in.lb.s ²	2.12	1.90	1.81	1.73	1.69

Reduced mass moments of inertia available on request.

^{a)} Other ratios available on request

^{b)} For higher ambient temperatures, please reduce input speed

^{c)} Valid for clamping hub diameter of 19 mm

^{d)} Refers to centre of the output shaft or flange

View A

View B

up to 14⁴⁾ (C)
clamping hub diameter

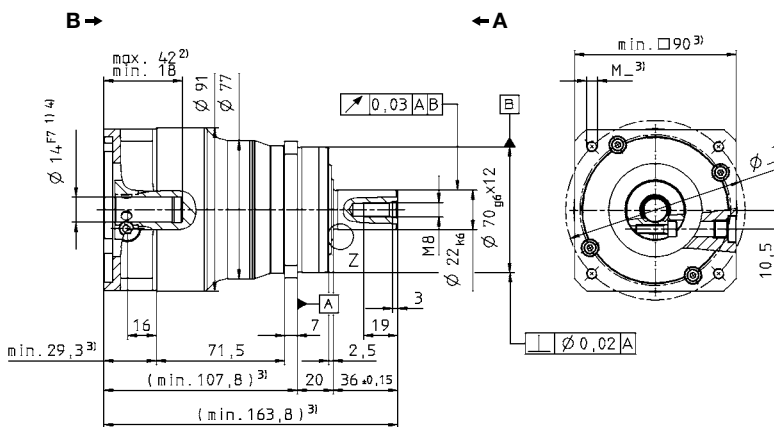
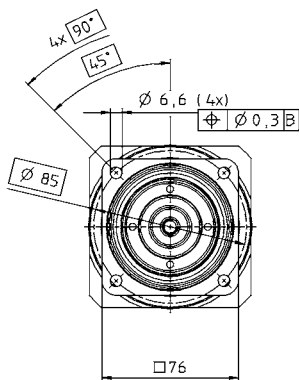

up to 19⁴⁾ (E)
clamping hub diameter

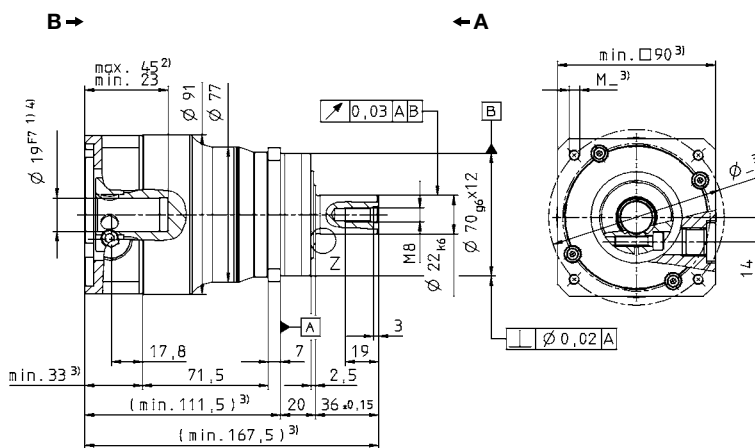
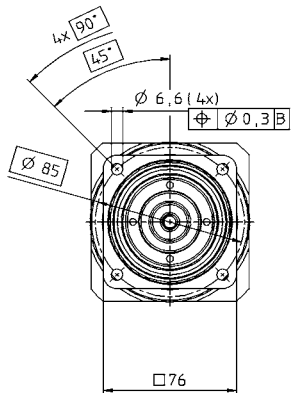

up to 24⁴⁾ (G)
clamping hub diameter

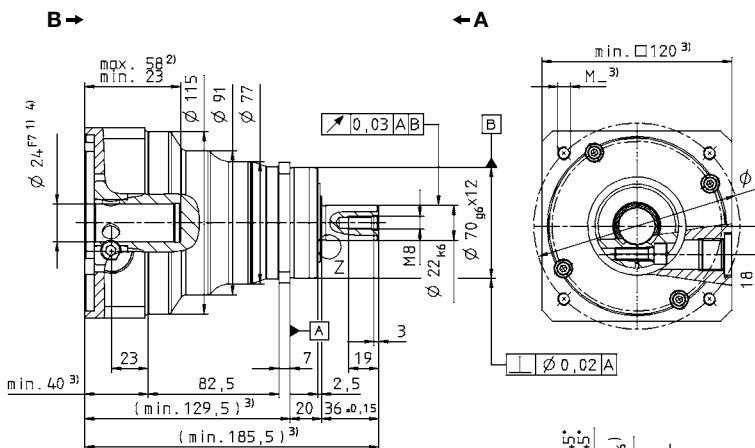
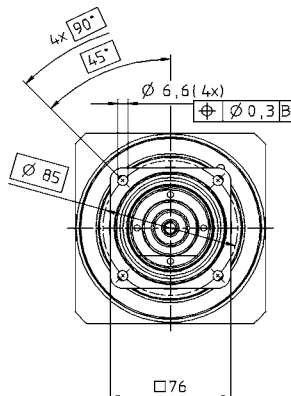

Alternatives: Output shaft variants

Keywayed output shaft in mm
E = key as per DIN 6885, sheet 1, form A

Involute gearing DIN 5480 in mm
X = W 22 x 1.25 x 30 x 16 x 6m, DIN 5480

Shaft mounted
Mounted via shrink disc

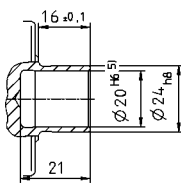
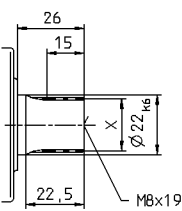
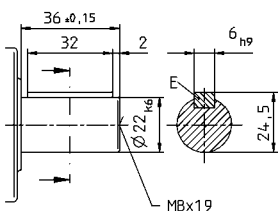

Non-tolerated dimensions ± 1 mm

- 1) Check motor shaft fit.
- 2) Min./Max. permissible motor shaft length.
Longer motor shafts are adaptable, please contact us.
- 3) The dimensions depend on the motor.
- 4) Smaller motor shaft diameter is compensated by a bushing with a minimum thickness of 1 mm.
- 5) Tolerance h6 for mounted shaft.

Motor mounting according to operating manual

SP*



SP+ 075 MF 2-stage

				2-stage									
Ratio ^{a)}		<i>i</i>		16	20	25	28	35	40	50	70	100	
cymex®-optimized acceleration torque (please contact us regarding the design)	T_{2Bcym}	Nm		142	142	160	142	160	135	160	142	100	
				in.lb	1254	1254	1416	1254	1416	1195	1416	1254	883
Max. acceleration torque (max. 1000 cycles per hour)	T_{2B}	Nm		110	110	110	110	110	110	110	110	90	
				in.lb	974	974	974	974	974	974	974	974	797
Nominal output torque (with n_{2N})	T_{2N}	Nm		75	75	75	75	75	75	75	75	52	
				in.lb	664	664	664	664	664	664	664	664	460
Emergency stop torque (permitted 1000 times during the service life of the gearhead)	T_{2Not}	Nm		250	250	250	250	250	250	250	250	200	
				in.lb	2213	2213	2213	2213	2213	2213	2213	2213	1770
Nominal input speed (with T_{2N} and 20°C ambient temperature) ^{b)}	n_{1N}	rpm		3500	3500	3500	3500	3500	3500	3800	4500	4500	
Max. input speed	n_{1Max}	rpm		6000	6000	6000	6000	6000	6000	6000	6000	6000	
Mean no load running torque (with $n_1=3000$ rpm and 20°C gearhead temperature) ^{c)}	T_{012}	Nm		0.8	0.6	0.6	0.5	0.4	0.4	0.3	0.3	0.3	
				in.lb	4.4	3.5	3.5	2.7	2.7	1.8	1.8	1.8	1.8
Max. torsional backlash	j_t	arcmin		Standard ≤ 6 / Reduced ≤ 4									
Torsional rigidity	C_{I21}	Nm/ arcmin		10									
				in.lb/ arcmin	89								
Max. axial force ^{d)}	F_{2AMax}	N		3350									
				lb _f	754								
Max. radial force ^{d)}	F_{2RMMax}	N		4200									
				lb _f	945								
Max. tilting moment	M_{2KMax}	Nm		236									
				in.lb	2089								
Efficiency at full load	η	%		94									
Service life (For calculation, see the Chapter "Information")	L_h	h		> 20000									
Weight incl. standard adapter plate	m	kg		3.6									
				lb _m	8.0								
Operating noise (with $i=100$ and $n_1=3000$ rpm no load)	L_{PA}	dB(A)		≤ 59									
Max. permitted housing temperature		°C		+90									
				F	194								
Ambient temperature		°C		-15 to +40									
				F	5 to 104								
Lubrication				Lubricated for life									
Paint				Blue RAL 5002									
Direction of rotation				Motor and gearhead same direction									
Protection class				IP 65									
Moment of inertia (relates to the drive)	B	11	J_1	kgcm ²	0.16	0.13	0.13	0.10	0.10	0.091	0.090	0.089	0.089
				10 ⁻³ in.lb.s ²	0.14	0.11	0.11	0.092	0.090	0.081	0.080	0.079	0.079
Clamping hub diameter [mm]	C	14	J_1	kgcm ²	0.23	0.20	0.20	0.18	0.18	0.17	0.16	0.16	0.16
				10 ⁻³ in.lb.s ²	0.20	0.18	0.18	0.16	0.16	0.15	0.15	0.14	0.14
	E	19	J_1	kgcm ²	0.55	0.53	0.52	0.50	0.50	0.49	0.49	0.49	0.49
				10 ⁻³ in.lb.s ²	0.49	0.47	0.46	0.44	0.44	0.43	0.43	0.43	0.43

Reduced mass moments of inertia available on request.

^{a)} Other ratios available on request

^{b)} For higher ambient temperatures, please reduce input speed

^{c)} Valid for clamping hub diameter of 14 mm

^{d)} Refers to centre of the output shaft or flange

View A

View B

up to 11⁴⁾ (B)
clamping hub diameter

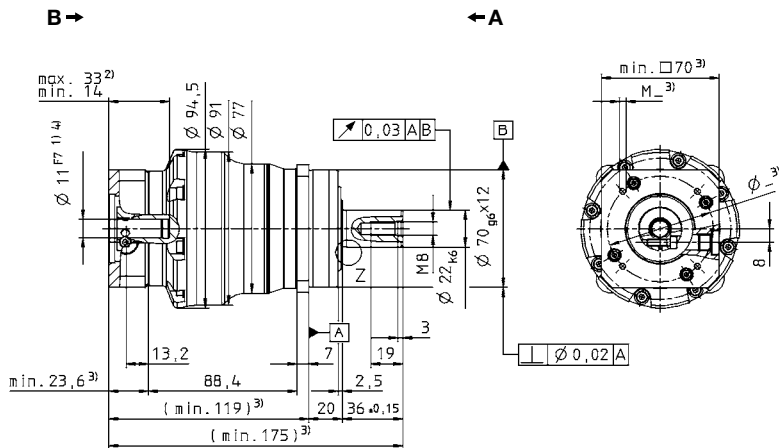
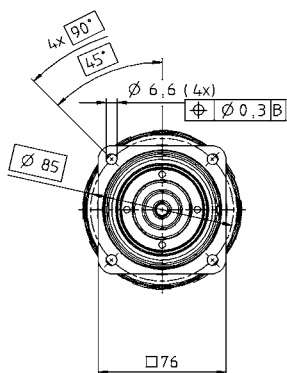

up to 14⁴⁾ (C)
clamping hub diameter

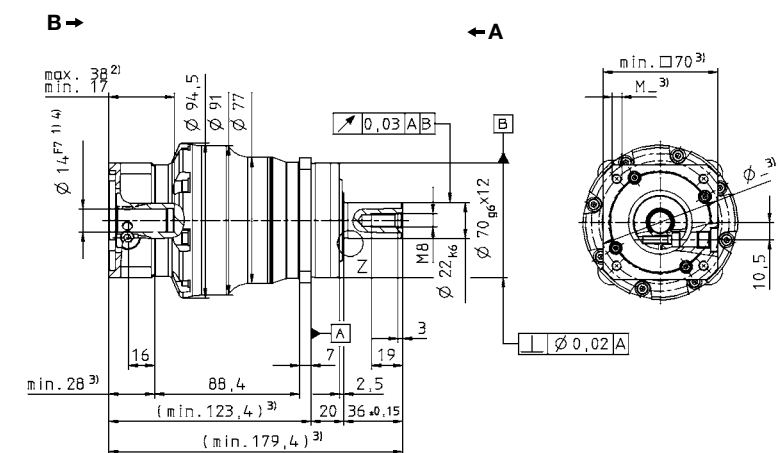
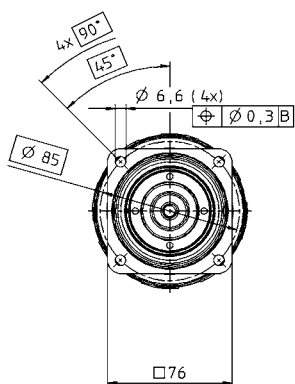

up to 19⁴⁾ (E)
clamping hub diameter

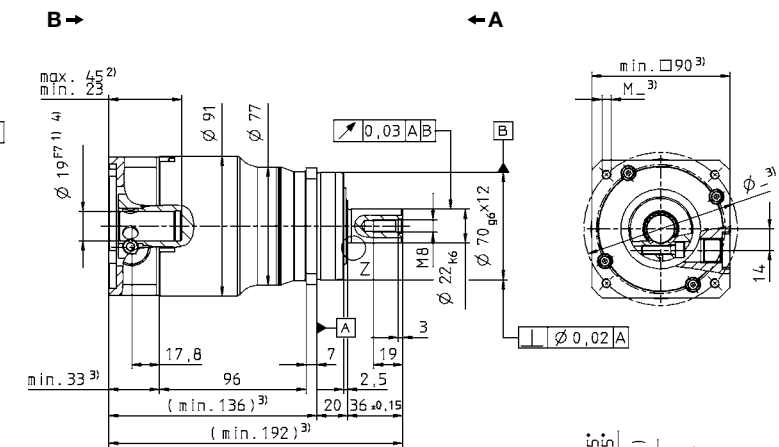
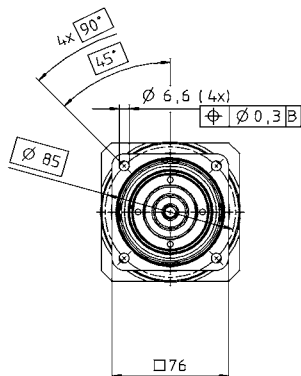

Alternatives: Output shaft variants

Keywayed output shaft in mm
E = key as per DIN 6885, sheet 1, form A

Involute gearing DIN 5480 in mm
X = W 22 x 1.25 x 30 x 16 x 6m, DIN 5480

Shaft mounted
Mounted via shrink disc

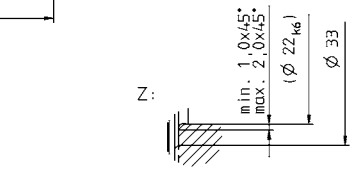
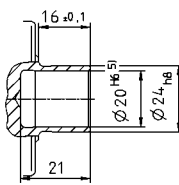
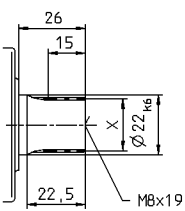
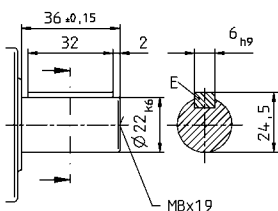

Non-tolerated dimensions ± 1 mm

- 1) Check motor shaft fit.
- 2) Min./Max. permissible motor shaft length.
Longer motor shafts are adaptable, please contact us.
- 3) The dimensions depend on the motor.
- 4) Smaller motor shaft diameter is compensated by a bushing with a minimum thickness of 1 mm.
- 5) Tolerance h6 for mounted shaft.

Motor mounting according to operating manual

SP*



SP+ 100 MF 1-stage

				1-stage					
Ratio ^{a)}		<i>i</i>		3	4	5	7	10	
cymex [®] -optimized acceleration torque (please contact us regarding the design)	T_{2Bcym}	Nm		–	370	400	330	260	
			in.lb	–	3275	3540	2921	2301	
Max. acceleration torque (max. 1000 cycles per hour)	T_{2B}	Nm		235	315	315	315	235	
			in.lb	2080	2788	2788	2788	2080	
Nominal output torque (with n_{1N})	T_{2N}	Nm		120	180	175	170	120	
			in.lb	1062	1593	1549	1505	1062	
Emergency stop torque (permitted 1000 times during the service life of the gearhead)	T_{2Not}	Nm		500	625	625	625	500	
			in.lb	4425	5531	5531	5531	4425	
Nominal input speed (with T_{2N} and 20°C ambient temperature) ^{b)}	n_{1N}	rpm		2500	2500	2500	2800	2800	
Max. input speed	n_{1Max}	rpm		4500	4500	4500	4500	4500	
Mean no load running torque (with $n_1=3000$ rpm and 20°C gearhead temperature) ^{c)}	T_{012}	Nm		3.5	2.7	2.4	1.6	1.4	
			in.lb	31.0	23.9	21.2	14.2	12.4	
Max. torsional backlash	j_t	arcmin		Standard ≤ 3 / Reduced ≤ 1					
Torsional rigidity	C_{I21}	Nm/ arcmin		31					
			in.lb/ arcmin	274					
Max. axial force ^{d)}	F_{2AMax}	N		5650					
			lb _f	1271					
Max. radial force ^{d)}	F_{2RMMax}	N		6600					
			lb _f	1485					
Max. tilting moment	M_{2KMax}	Nm		487					
			in.lb	4310					
Efficiency at full load	η	%		97					
Service life (For calculation, see the Chapter "Information")	L_h	h		> 20000					
Weight incl. standard adapter plate	m	kg		7.7					
			lb _m	17.0					
Operating noise (with $i=10$ and $n_1=3000$ rpm no load)	L_{PA}	dB(A)		≤ 64					
Max. permitted housing temperature			°C	+90					
			F	17.0					
Ambient temperature			°C	-15 to +40					
			F	5 to 104					
Lubrication				Lubricated for life					
Paint				Blue RAL 5002					
Direction of rotation				Motor and gearhead same direction					
Protection class				IP 65					
Moment of inertia (relates to the drive)	E	19	J_1	kgcm ²	3.29	2.35	1.92	1.60	1.38
				10 ⁻⁴ in.lb.s ²	2.91	2.08	1.70	1.42	1.22
Clamping hub diameter [mm]	G	24	J_1	kgcm ²	3.99	3.04	2.61	2.29	2.07
				10 ⁻⁴ in.lb.s ²	3.53	2.69	2.31	2.03	1.83
	H	28	J_1	kgcm ²	3.59	2.65	2.22	1.90	1.68
				10 ⁻⁴ in.lb.s ²	3.18	2.35	1.97	1.68	1.49
K	38	J_1	kgcm ²	11.1	10.1	9.68	9.36	9.14	
			10 ⁻⁴ in.lb.s ²	9.78	8.95	8.57	8.28	8.09	

Reduced mass moments of inertia available on request.

^{a)} Other ratios available on request

^{b)} For higher ambient temperatures, please reduce input speed

^{c)} Valid for clamping hub diameter of 24 mm

^{d)} Refers to centre of the output shaft or flange

View A

View B

up to 19⁴⁾ (E)
clamping hub diameter

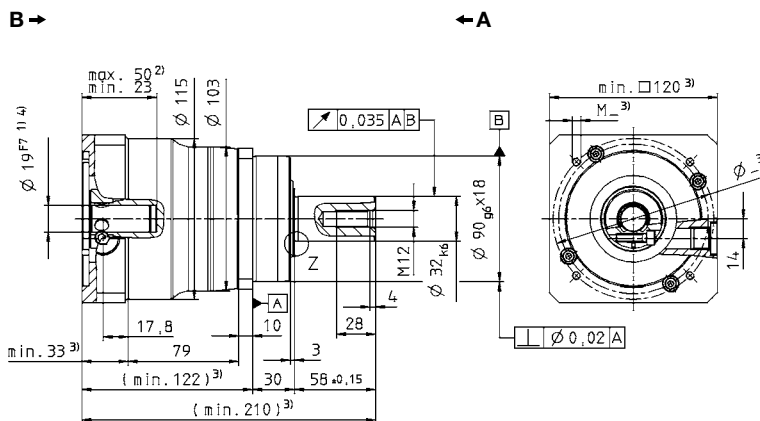
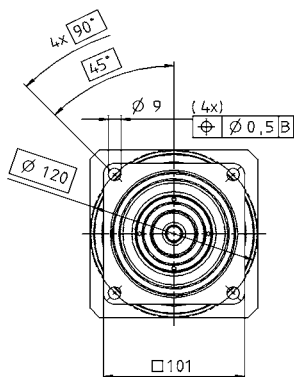

up to 24/28⁴⁾ (G/H)
clamping hub diameter

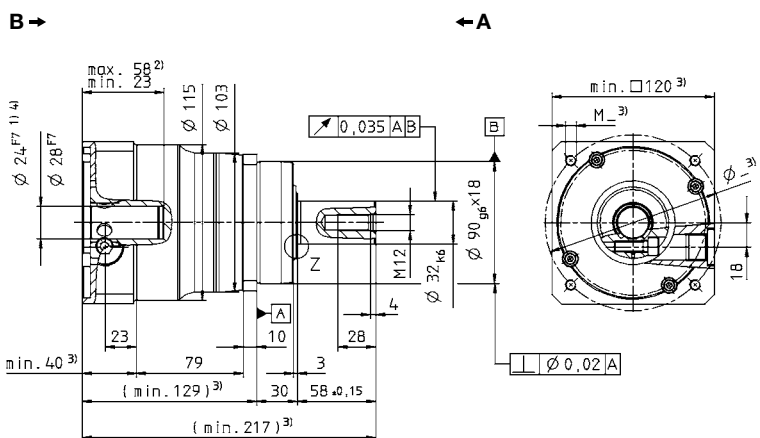
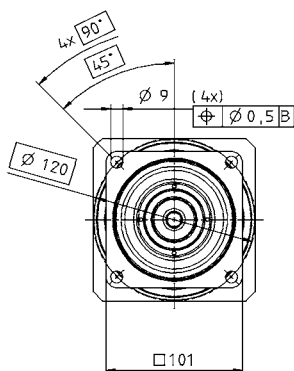

up to 38⁴⁾ (K)
clamping hub diameter

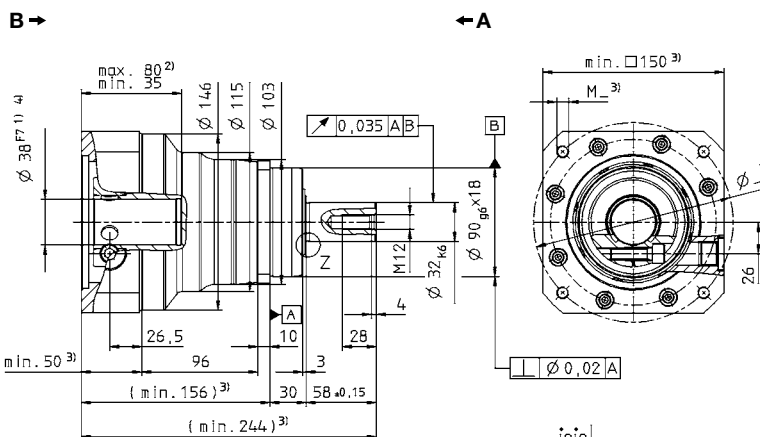
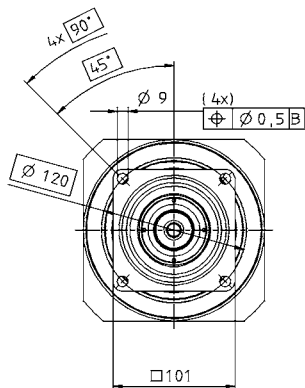

Alternatives: Output shaft variants

Keywayed output shaft in mm
E = key as per DIN 6885, sheet 1, form A

Involute gearing DIN 5480 in mm
X = W 32 x 1.25 x 30 x 24 x 6m, DIN 5480

Shaft mounted
Mounted via shrink disc

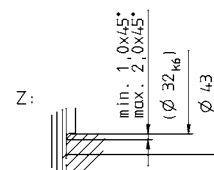
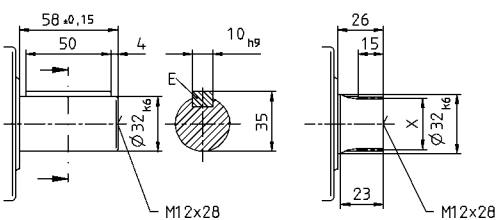

Non-tolerated dimensions ± 1 mm

- 1) Check motor shaft fit.
- 2) Min./Max. permissible motor shaft length.
Longer motor shafts are adaptable, please contact us.
- 3) The dimensions depend on the motor.
- 4) Smaller motor shaft diameter is compensated by a bushing with a minimum thickness of 1 mm.
- 5) Tolerance h6 for mounted shaft.

Motor mounting according to operating manual

SP



SP+ 100 MF 2-stage

				2-stage									
Ratio ^{a)}		<i>i</i>		16	20	25	28	35	40	50	70	100	
cymex [®] -optimized acceleration torque (please contact us regarding the design)	T_{2Bcym}	Nm		370	370	400	370	400	370	400	330	260	
				in.lb	3275	3275	3540	3275	3540	3275	3540	2921	2301
Max. acceleration torque (max. 1000 cycles per hour)	T_{2B}	Nm		315	315	315	315	315	315	315	315	235	
				in.lb	2788	2788	2788	2788	2788	2788	2788	2788	2080
Nominal output torque (with n_{2N})	T_{2N}	Nm		180	180	175	180	175	180	175	170	120	
				in.lb	1593	1593	1549	1593	1549	1593	1549	1505	1062
Emergency stop torque (permitted 1000 times during the service life of the gearhead)	T_{2Not}	Nm		625	625	625	625	625	625	625	625	500	
				in.lb	5531	5531	5531	5531	5531	5531	5531	5531	4425
Nominal input speed (with T_{2N} and 20°C ambient temperature) ^{b)}	n_{1N}	rpm		3100	3100	3100	3100	3100	3100	3500	4200	4200	
Max. input speed	n_{1Max}	rpm		6000	6000	6000	6000	6000	6000	6000	6000	6000	
Mean no load running torque (with $n_1=3000$ rpm and 20°C gearhead temperature) ^{c)}	T_{012}	Nm		1.5	1.2	1.1	0.9	0.8	0.7	0.6	0.5	0.5	
		in.lb		13.3	10.6	9.7	8.8	7.1	6.2	5.3	4.4	4.4	
Max. torsional backlash	j_t	arcmin		Standard ≤ 5 / Reduced ≤ 3									
Torsional rigidity	C_{I21}	Nm/ arcmin		31									
		in.lb/ arcmin		274									
Max. axial force ^{d)}	F_{2AMax}	N		5650									
		lb _f		1271									
Max. radial force ^{d)}	F_{2RMMax}	N		6600									
		lb _f		1485									
Max. tilting moment	M_{2KMax}	Nm		487									
		in.lb		4310									
Efficiency at full load	η	%		94									
Service life (For calculation, see the Chapter "Information")	L_h	h		> 20000									
Weight incl. standard adapter plate	m	kg		7.9									
		lb _m		17.5									
Operating noise (with $i=100$ and $n_1=3000$ rpm no load)	L_{PA}	dB(A)		≤ 60									
Max. permitted housing temperature		°C		+90									
		F		194									
Ambient temperature		°C		-15 to +40									
		F		5 to 104									
Lubrication				Lubricated for life									
Paint				Blue RAL 5002									
Direction of rotation				Motor and gearhead same direction									
Protection class				IP 65									
Moment of inertia (relates to the drive)	C	14	J_1	kgcm ²	0.64	0.54	0.52	0.43	0.43	0.38	0.38	0.37	0.37
				10 ⁻³ in.lb.s ²	0.57	0.47	0.46	0.38	0.38	0.34	0.33	0.33	0.33
Clamping hub diameter [mm]	E	19	J_1	kgcm ²	0.81	0.70	0.69	0.60	0.59	0.55	0.54	0.54	0.54
				10 ⁻³ in.lb.s ²	0.72	0.62	0.61	0.53	0.52	0.48	0.48	0.48	0.47
	G	24	J_1	kgcm ²	2.18	2.07	2.05	1.97	1.96	1.92	1.91	1.91	1.91
				10 ⁻³ in.lb.s ²	1.93	1.83	1.82	1.74	1.74	1.70	1.69	1.69	1.69

Reduced mass moments of inertia available on request.

^{a)} Other ratios available on request

^{b)} For higher ambient temperatures, please reduce input speed

^{c)} Valid for clamping hub diameter of 19 mm

^{d)} Refers to centre of the output shaft or flange

View A

View B

up to 14⁴⁾ (C)
clamping hub diameter

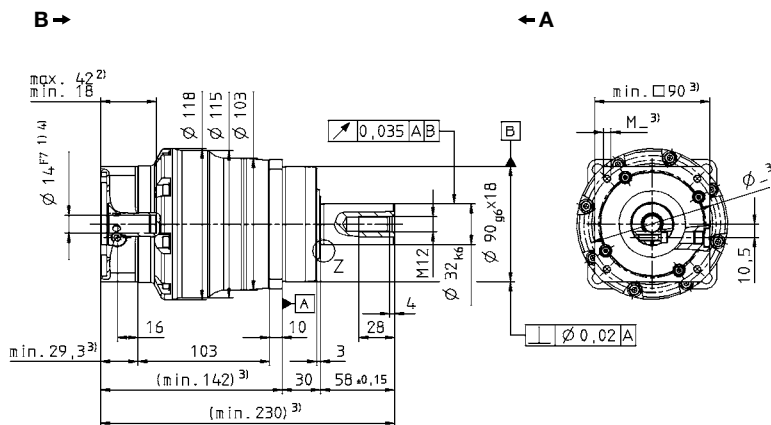
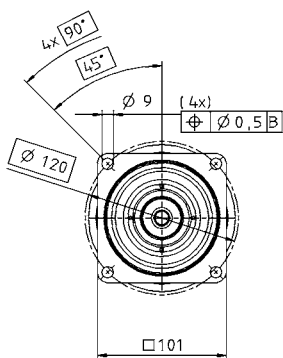

up to 19⁴⁾ (E)
clamping hub diameter

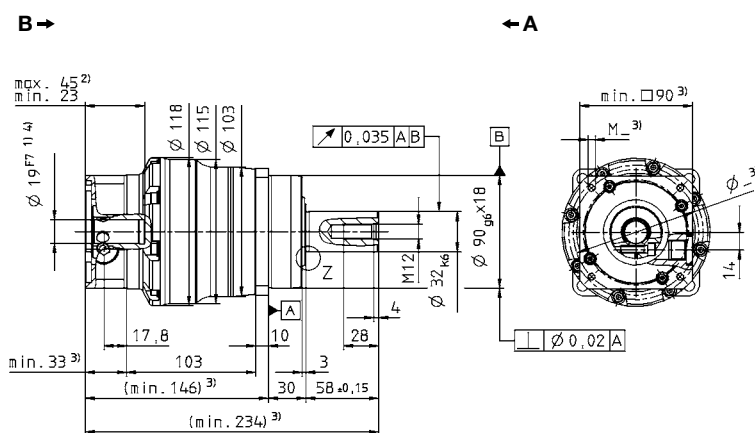
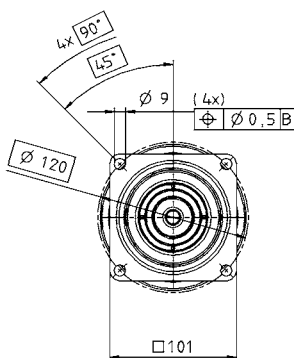

up to 24⁴⁾ (G)
clamping hub diameter

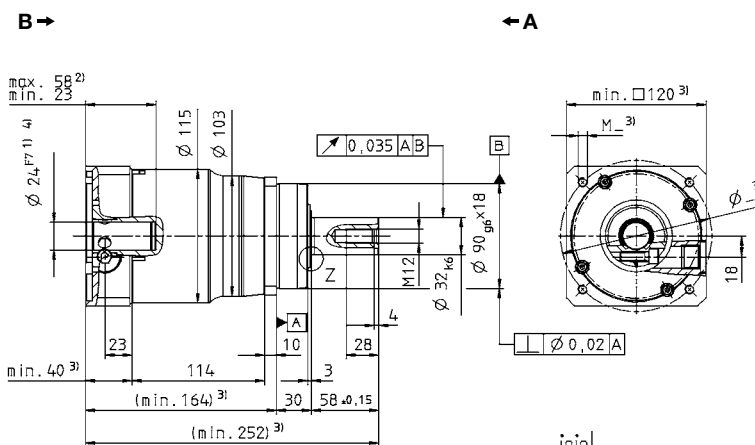
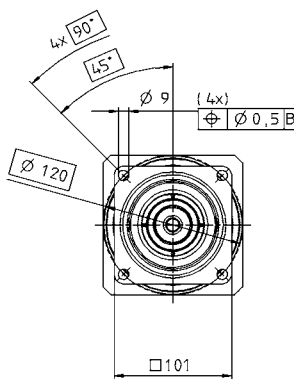

Alternatives: Output shaft variants

Keywayed output shaft in mm
E = key as per DIN 6885, sheet 1, form A

Involute gearing DIN 5480 in mm
X = W 32 x 1.25 x 30 x 24 x 6m, DIN 5480

Shaft mounted
Mounted via shrink disc

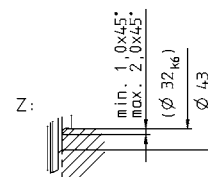
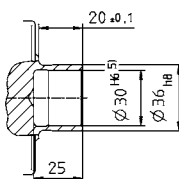
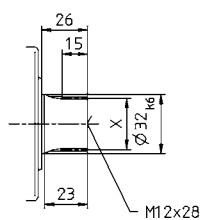
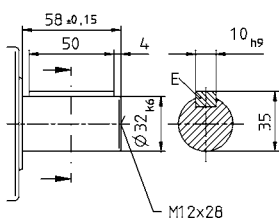

Non-tolerated dimensions ± 1 mm

- 1) Check motor shaft fit.
- 2) Min./Max. permissible motor shaft length.
Longer motor shafts are adaptable, please contact us.
- 3) The dimensions depend on the motor.
- 4) Smaller motor shaft diameter is compensated by a bushing with a minimum thickness of 1 mm.
- 5) Tolerance h6 for mounted shaft.

Motor mounting according to operating manual

SP



SP+ 140 MF 1-stage

				1-stage					
Ratio ^{a)}	<i>i</i>			3	4	5	7	10	
cymex®-optimized acceleration torque (please contact us regarding the design)	T_{2Bcym}	Nm		–	710	755	680	560	
		in.lb		–	6284	6682	6018	4956	
Max. acceleration torque (max. 1000 cycles per hour)	T_{2B}	Nm		390	660	660	660	530	
		in.lb		3451.5	5841	5841	5841	4691	
Nominal output torque (with n_{1N})	T_{2N}	Nm		200	360	360	360	220	
		in.lb		1770	3186	3186	3186	1947	
Emergency stop torque (permitted 1000 times during the service life of the gearhead)	T_{2Not}	Nm		1000	1250	1250	1250	1000	
		in.lb		8850	11063	11063	11063	8850	
Nominal input speed (with T_{2N} and 20°C ambient temperature) ^{b)}	n_{1N}	rpm		2100	2100	2100	2600	2600	
Max. input speed	n_{1Max}	rpm		4000	4000	4000	4000	4000	
Mean no load running torque (with $n_1=3000$ rpm and 20°C gearhead temperature) ^{c)}	T_{012}	Nm		7.6	5.8	4.7	3.4	2.5	
		in.lb		67	51	42	30	22	
Max. torsional backlash	j_t	arcmin		Standard ≤ 3 / Reduced ≤ 1					
Torsional rigidity	C_{I21}	Nm/ arcmin		53					
		in.lb/ arcmin		469					
Max. axial force ^{d)}	F_{2AMax}	N		9870					
		lb _f		2221					
Max. radial force ^{d)}	F_{2RMMax}	N		9900					
		lb _f		2228					
Max. tilting moment	M_{2KMax}	Nm		952					
		in.lb		8425					
Efficiency at full load	η	%		97					
Service life (For calculation, see the Chapter "Information")	L_h	h		> 20000					
Weight incl. standard adapter plate	m	kg		17.2					
		lb _m		38.0					
Operating noise (with $i=10$ and $n_1=3000$ rpm no load)	L_{PA}	dB(A)		≤ 65					
Max. permitted housing temperature			°C		+90				
			F		194				
Ambient temperature			°C		-15 to +40				
			F		5 to 104				
Lubrication				Lubricated for life					
Paint				Blue RAL 5002					
Direction of rotation				Motor and gearhead same direction					
Protection class				IP 65					
Moment of inertia (relates to the drive)	G	24	J_1	kgcm ²	10.7	7.82	6.79	5.84	5.28
				10 ⁻⁴ in.lb.s ²	9.45	6.92	6.01	5.17	4.67
Clamping hub diameter [mm]	I	32	J_1	kgcm ²	13.8	11.0	9.95	9.01	8.44
				10 ⁻⁴ in.lb.s ²	12.3	9.72	8.81	7.97	7.47
	K	38	J_1	kgcm ²	14.9	12.1	11.0	10.1	9.51
				10 ⁻⁴ in.lb.s ²	13.2	10.7	9.76	8.92	8.42
M	48	J_1	kgcm ²	29.5	26.7	25.6	24.7	24.2	
			10 ⁻⁴ in.lb.s ²	26.1	23.6	22.7	21.9	21.4	

Reduced mass moments of inertia available on request.

^{a)} Other ratios available on request

^{b)} For higher ambient temperatures, please reduce input speed

^{c)} Valid for clamping hub diameter of 38 mm

^{d)} Refers to center of the output shaft or flange

View A

View B

up to 24⁴⁾ (G)
clamping hub diameter

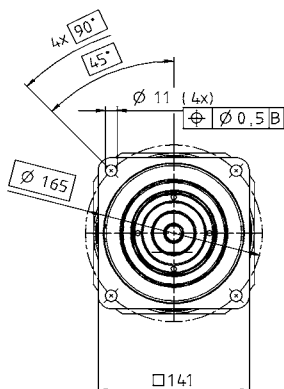

up to 32/38⁴⁾
(I/K) clamping
hub diameter

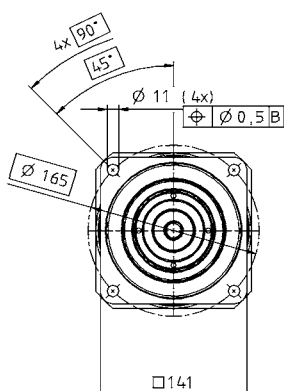

up to 48⁴⁾ (M)
clamping hub diameter

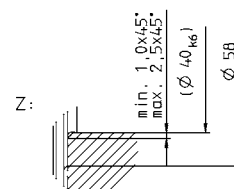
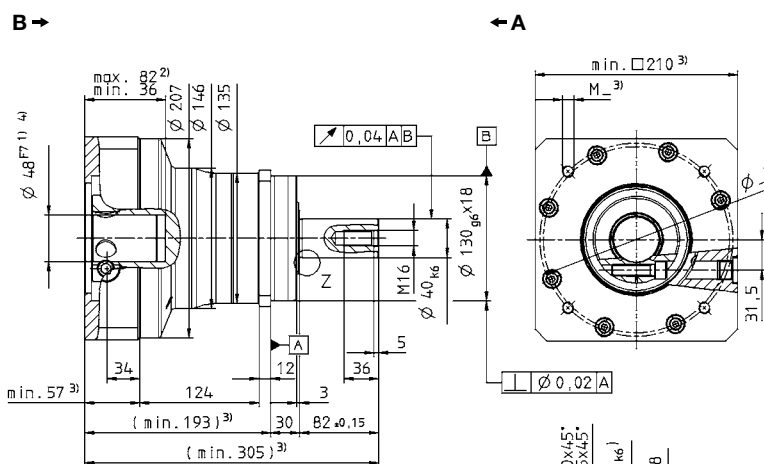
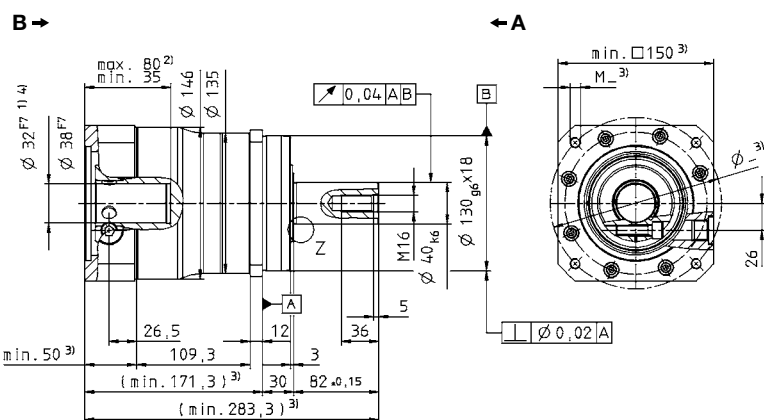
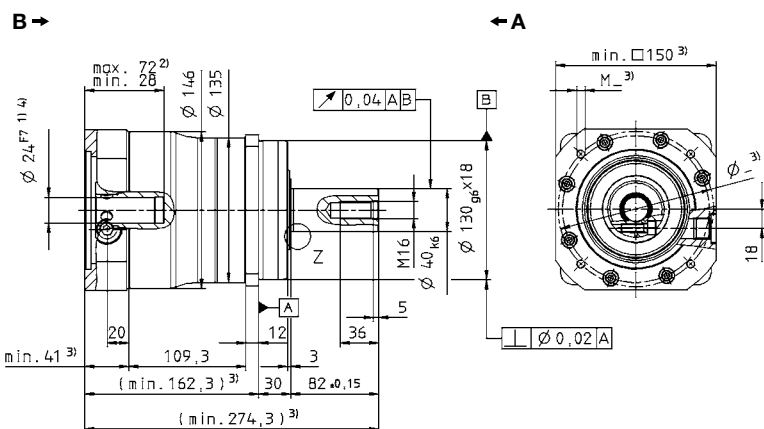
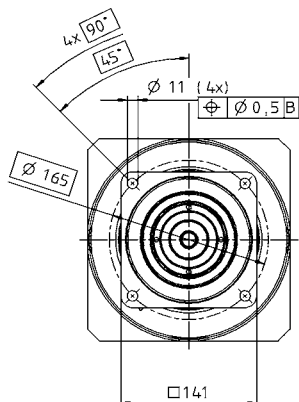

Alternatives: Output shaft variants

Keywayed output shaft in mm
E = key as per DIN 6885, sheet 1, form A

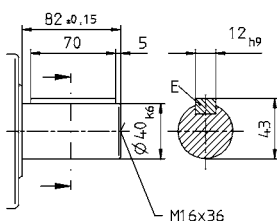

Involute gearing DIN 5480 in mm
X = W 40 x 2 x 30 x 18 x 6, DIN 5480

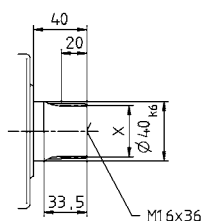

Shaft mounted
Mounted via shrink disc

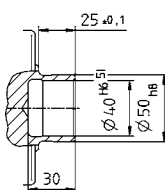

Non-tolerated dimensions ± 1 mm

- 1) Check motor shaft fit.
- 2) Min./Max. permissible motor shaft length.
Longer motor shafts are adaptable, please contact us.
- 3) The dimensions depend on the motor.
- 4) Smaller motor shaft diameter is compensated by a bushing with a minimum thickness of 1 mm.
- 5) Tolerance h6 for mounted shaft.

⚠ Motor mounting according to operating manual

SP*



SP+ 140 MF 2-stage

				2-stage									
Ratio ^{a)}		<i>i</i>		16	20	25	28	35	40	50	70	100	
cymex®-optimized acceleration torque (please contact us regarding the design)	T_{2Bcym}	Nm		710	710	755	710	755	710	755	680	560	
				in.lb	6284	6284	6682	6284	6682	6284	6682	6018	4956
Max. acceleration torque (max. 1000 cycles per hour)	T_{2B}	Nm		660	660	660	660	660	660	660	660	530	
				in.lb	5841	5841	5841	5841	5841	5841	5841	5841	4691
Nominal output torque (with n_{2N})	T_{2N}	Nm		360	360	360	360	360	360	360	360	220	
				in.lb	3186	3186	3186	3186	3186	3186	3186	3186	1947
Emergency stop torque (permitted 1000 times during the service life of the gearhead)	T_{2Not}	Nm		1250	1250	1250	1250	1250	1250	1250	1250	1000	
				in.lb	11063	11063	11063	11063	11063	11063	11063	11063	8850
Nominal input speed (with T_{2N} and 20°C ambient temperature) ^{b)}	n_{1N}	rpm		2900	2900	2900	2900	2900	2900	3200	3200	3900	
Max. input speed ^{c)}	n_{1Max}	rpm		5000	5000	5000	5000	5000	5000	5000	5000	5000	
Mean no load running torque (with $n_1=3000$ rpm and 20°C gearhead temperature) ^{d)}	T_{012}	Nm		3.3	2.7	2.4	1.9	1.8	1.4	1.3	1.2	1.1	
		in.lb		29.2	23.9	21.2	16.9	15.9	12.4	11.5	10.6	9.7	
Max. torsional backlash	j_t	arcmin		Standard ≤ 5 / Reduced ≤ 3									
Torsional rigidity	C_{I21}	Nm/ arcmin		53									
		in.lb/ arcmin		469									
Max. axial force ^{d)}	F_{2AMax}	N		9870									
		lb _f		2221									
Max. radial force ^{d)}	F_{2RMax}	N		9900									
		lb _f		2228									
Max. tilting moment	M_{2KMax}	Nm		952									
		in.lb		8425									
Efficiency at full load	η	%		94									
Service life (For calculation, see the Chapter "Information")	L_h	h		> 20000									
Weight incl. standard adapter plate	m	kg		17									
		lb _m		37.6									
Operating noise (with $i=100$ and $n_1=3000$ rpm no load)	L_{PA}	dB(A)		≤ 63									
Max. permitted housing temperature		°C		+90									
		F		194									
Ambient temperature		°C		-15 to +40									
		F		5 to 104									
Lubrication				Lubricated for life									
Paint				Blue RAL 5002									
Direction of rotation				Motor and gearhead same direction									
Protection class				IP 65									
Moment of inertia (relates to the drive)	E	19	J_1	kgcm ²	2.50	2.01	1.97	1.65	1.63	1.40	1.39	1.38	1.38
				10 ⁻³ in.lb.s ²	2.21	1.78	1.75	1.46	1.44	1.24	1.23	1.22	1.22
Clamping hub diameter [mm]	G	24	J_1	kgcm ²	3.19	2.71	2.67	2.34	2.32	2.10	2.08	2.08	2.07
				10 ⁻³ in.lb.s ²	2.82	2.40	2.36	2.07	2.05	1.85	1.85	1.84	1.83
	K	38	J_1	kgcm ²	10.3	9.77	9.73	9.41	9.39	9.16	9.15	9.14	9.14
				10 ⁻³ in.lb.s ²	9.07	8.65	8.61	8.33	8.31	8.11	8.10	8.09	8.09

Reduced mass moments of inertia available on request.

^{a)} Other ratios available on request

^{b)} For higher ambient temperatures, please reduce input speed

^{c)} Valid for clamping hub diameter of 24 mm

^{d)} Refers to center of the output shaft or flange

View A

View B

up to 19⁴⁾ (E)
clamping hub diameter

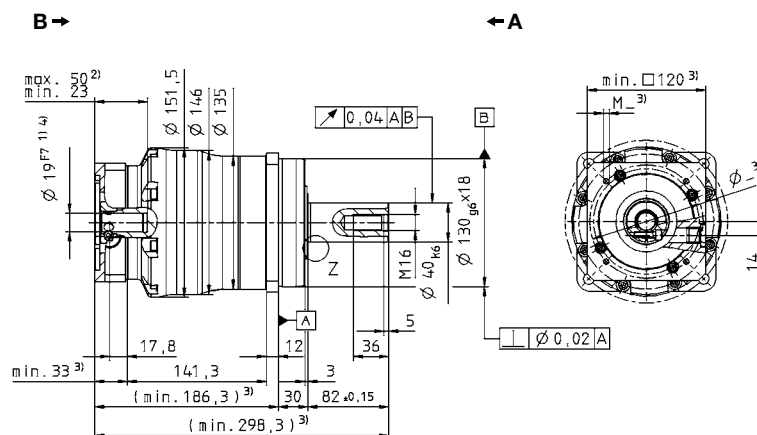
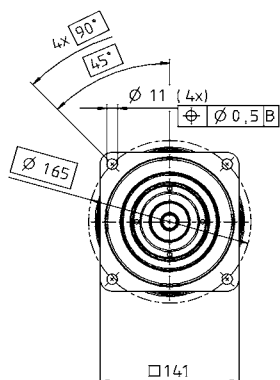

up to 24⁴⁾ (G)
clamping hub diameter

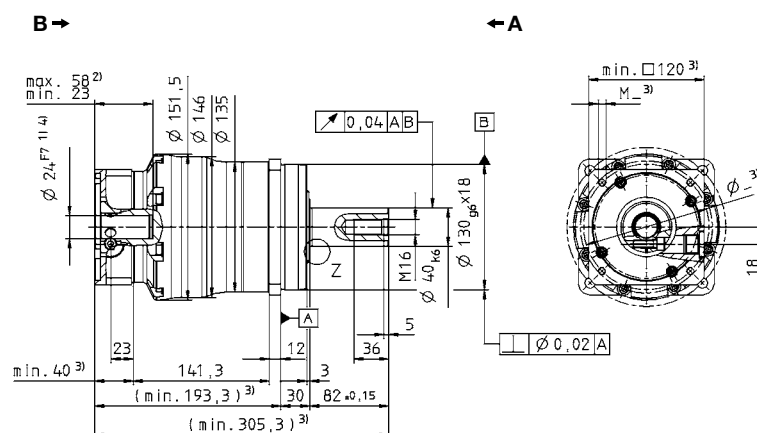
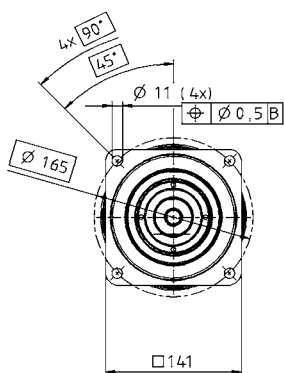

up to 38⁴⁾ (K)
clamping hub diameter

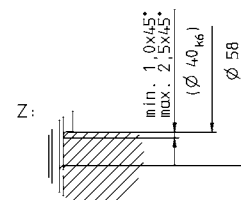
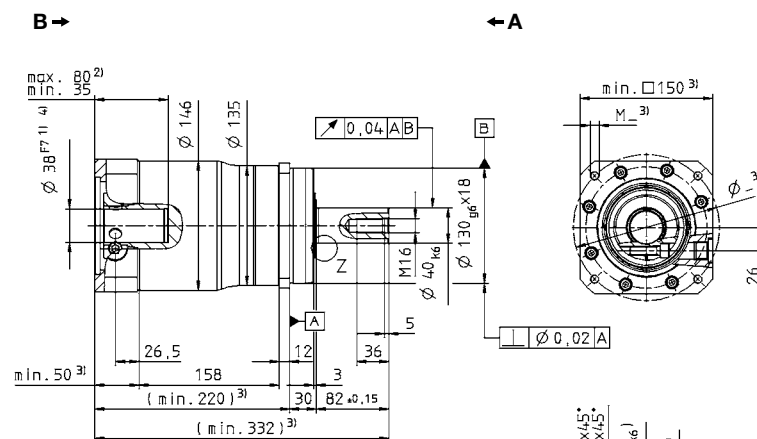
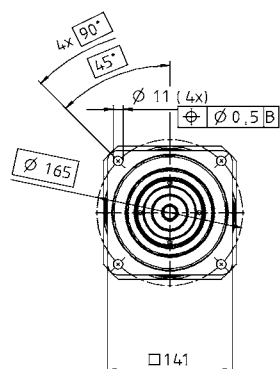

Alternatives: Output shaft variants

Keywayed output shaft in mm
E = key as per DIN 6885, sheet 1, form A

Involute gearing DIN 5480 in mm
X = W 40 x 2 x 30 x 18 x 6m, DIN 5480

Shaft mounted
Mounted via shrink disc

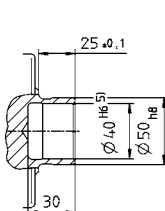
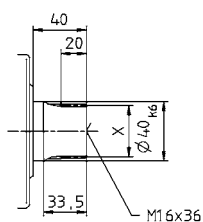
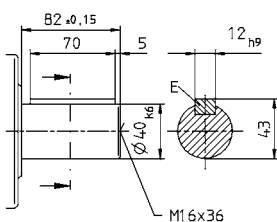

Non-tolerated dimensions ± 1 mm

- 1) Check motor shaft fit.
- 2) Min./Max. permissible motor shaft length.
Longer motor shafts are adaptable, please contact us.
- 3) The dimensions depend on the motor.
- 4) Smaller motor shaft diameter is compensated by a bushing with a minimum thickness of 1 mm.
- 5) Tolerance h6 for mounted shaft.

⚠ Motor mounting according to operating manual

SP*



SP+ 180 MF 1-stage

				1-stage					
Ratio ^{a)}		<i>i</i>		3	4	5	7	10	
cymex®-optimized acceleration torque (please contact us regarding the design)	T_{2Bcym}	Nm		–	1785	1890	1785	1400	
			in.lb	–	15797	16727	15797	12390	
Max. acceleration torque (max. 1000 cycles per hour)	T_{2B}	Nm		970	1210	1210	1210	970	
			in.lb	8585	10709	10709	10709	8585	
Nominal output torque (with n_{2N})	T_{2N}	Nm		530	750	750	750	750	
			in.lb	4691	6638	6638	6638	6638	
Emergency stop torque (permitted 1000 times during the service life of the gearhead)	T_{2Not}	Nm		2200	2750	2750	2750	2200	
			in.lb	19470	24338	24338	24338	29470	
Nominal input speed (with T_{2N} and 20°C ambient temperature) ^{b)}	n_{1N}	rpm		1500	1500	1500	2300	2300	
Max. input speed	n_{1Max}	rpm		3500	3500	3500	3500	3500	
Mean no load running torque (with $n_1=3000$ rpm and 20°C gearhead temperature) ^{c)}	T_{012}	Nm		14.0	11.0	9.0	6.8	5.0	
		in.lb		123.9	97.4	79.7	60.2	44.3	
Max. torsional backlash	j_t	arcmin		Standard ≤ 3 / Reduced ≤ 1					
Torsional rigidity	C_{I21}	Nm/ arcmin		175					
		in.lb/ arcmin		1549					
Max. axial force ^{d)}	F_{2AMax}	N		14150					
		lb _f		3184					
Max. radial force ^{d)}	F_{2RMax}	N		15400					
		lb _f		3465					
Max. tilting moment	M_{2KMax}	Nm		1600					
		in.lb		14160					
Efficiency at full load	η	%		97					
Service life (For calculation, see the Chapter "Information")	L_h	h		> 20000					
Weight incl. standard adapter plate	m	kg		34					
		lb _m		75.1					
Operating noise (with $i=10$ and $n_1=3000$ rpm no load)	L_{PA}	dB(A)		≤ 66					
Max. permitted housing temperature		°C		+90					
		F		194					
Ambient temperature		°C		-15 to +40					
		F		5 to 104					
Lubrication				Lubricated for life					
Paint				Blue RAL 5002					
Direction of rotation				Motor and gearhead same direction					
Protection class				IP 65					
Moment of inertia (relates to the drive)	K	38	J_1	kgcm ²	50.8	33.9	27.9	22.2	19.2
				10 ⁻³ in.lb.s ²	45.0	30.0	24.7	19.7	17.0
Clamping hub diameter [mm]	M	48	J_1	kgcm ²	58.2	41.2	35.3	29.6	26.5
				10 ⁻³ in.lb.s ²	51.5	36.5	31.2	26.2	23.5

Reduced mass moments of inertia available on request.

^{a)} Other ratios available on request

^{b)} For higher ambient temperatures, please reduce input speed

^{c)} Valid for clamping hub diameter of 48 mm

^{d)} Refers to center of the output shaft or flange

View A

View B

Motor shaft diameter [mm]

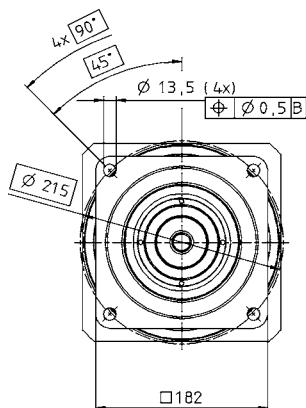
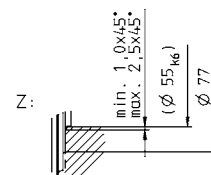
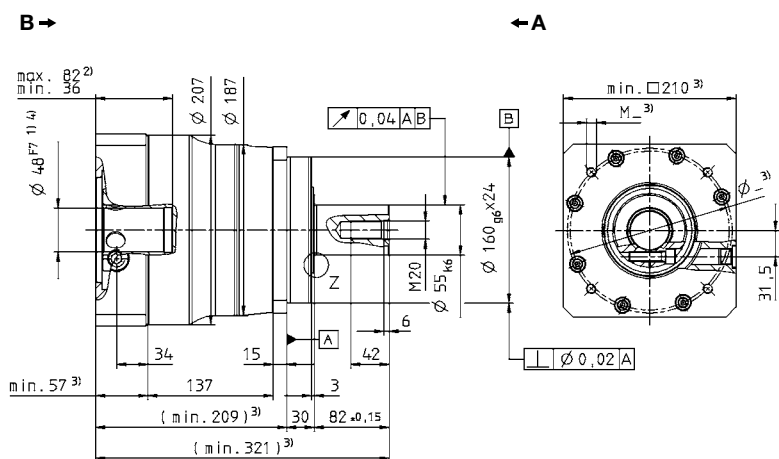
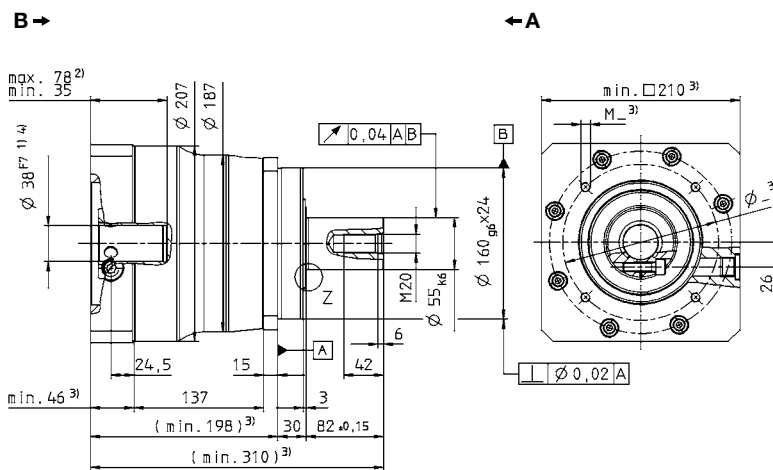
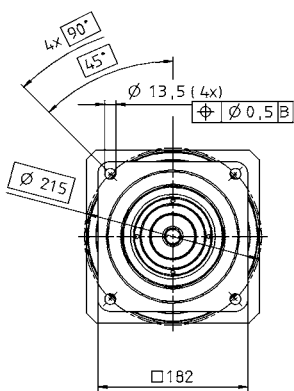
 up to 38⁴⁾ (K)
clamping hub diameter

 up to 48⁴⁾ (M)
clamping hub diameter

Alternatives: Output shaft variants

 Keywayed output shaft in mm
E = key as per DIN 6885, sheet 1, form A

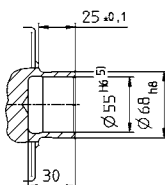
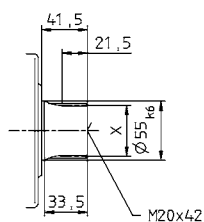
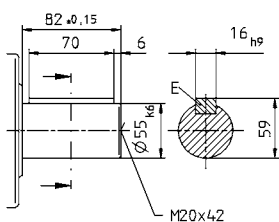
 Involute gearing DIN 5480 in mm
X = W 55 x 2 x 30 x 26 x 6m, DIN 5480

 Shaft mounted
Mounted via shrink disc

Non-tolerated dimensions ± 1 mm

- 1) Check motor shaft fit.
- 2) Min./Max. permissible motor shaft length.
Longer motor shafts are adaptable, please contact us.
- 3) The dimensions depend on the motor.
- 4) Smaller motor shaft diameter is compensated by a bushing with a minimum thickness of 1 mm.
- 5) Tolerance h6 for mounted shaft.

Motor mounting according to operating manual

SP



SP+ 180 MF 2-stage

				2-stage									
Ratio ^{a)}		<i>i</i>		16	20	25	28	35	40	50	70	100	
cymex®-optimized acceleration torque (please contact us regarding the design)	T_{2Bcym}	Nm		1785	1785	1890	1785	1890	1785	1800	1785	1400	
				in.lb	15797	15797	16727	15797	16727	15797	15930	15797	12390
Max. acceleration torque (max. 1000 cycles per hour)	T_{2B}	Nm		1210	1210	1210	1210	1210	1210	1210	1210	970	
				in.lb	10709	10709	10709	10709	10709	10709	10709	10709	8585
Nominal output torque (with n_{2N})	T_{2N}	Nm		750	750	750	750	750	750	750	750	750	
				in.lb	6638	6638	6638	6638	6638	6638	6637	6638	6638
Emergency stop torque (permitted 1000 times during the service life of the gearhead)	T_{2Not}	Nm		2750	2750	2750	2750	2750	2750	2750	2750	2200	
				in.lb	24338	24338	24338	24338	24338	24338	24338	24338	19470
Nominal input speed (with T_{2N} and 20°C ambient temperature) ^{b)}	n_{1N}	rpm		2700	2700	2700	2700	2700	2700	2900	3200	3400	
Max. input speed ^{c)}	n_{1Max}	rpm		4500	4500	4500	4500	4500	4000	4500	4500	4500	
Mean no load running torque (with $n_1=3000$ rpm and 20°C gearhead temperature) ^{d)}	T_{012}	Nm		5.3	4.3	3.9	3.1	2.8	2.3	2.1	1.9	1.7	
				in.lb	46,9	38,1	34,5	27,4	24,8	20,4	18,6	16,8	15,0
Max. torsional backlash	j_t	arcmin		Standard ≤ 5 / Reduced ≤ 3									
Torsional rigidity	C_{I21}	Nm/ arcmin		175									
				in.lb/ arcmin	1549								
Max. axial force ^{d)}	F_{2AMax}	N		14150									
				lb _f	3184								
Max. radial force ^{d)}	F_{2RMMax}	N		15400									
				lb _f	3465								
Max. tilting moment	M_{2KMax}	Nm		1600									
				in.lb	14160								
Efficiency at full load	η	%		94									
Service life (For calculation, see the Chapter "Information")	L_h	h		> 20000									
Weight incl. standard adapter plate	m	kg		36.4									
				lb _m	80.4								
Operating noise (with $i=100$ and $n_1=3000$ rpm no load)	L_{PA}	dB(A)		≤ 66									
Max. permitted housing temperature		°C		+90									
				F	194								
Ambient temperature		°C		-15 to +40									
				F	5 to 104								
Lubrication				Lubricated for life									
Paint				Blue RAL 5002									
Direction of rotation				Motor and gearhead same direction									
Protection class				IP 65									
Moment of inertia (relates to the drive)	G	24	J_1	kgcm ²	9.27	7.72	7.48	6.32	6.20	5.51	5.45	5.39	5.36
				10 ⁻⁴ in.lb.s ²	8.20	6.83	6.62	5.59	5.49	4.88	4.82	4.77	4.74
Clamping hub diameter [mm]	I	32	J_1	kgcm ²	12.4	10.9	10.6	9.48	9.36	8.67	8.61	8.55	8.52
				10 ⁻⁴ in.lb.s ²	11.0	9.63	9.42	8.39	8.28	7.67	7.62	7.57	7.54
	K	38	J_1	kgcm ²	13.5	12.0	11.7	10.6	10.4	9.74	9.68	9.63	9.60
				10 ⁻⁴ in.lb.s ²	12.0	10.6	10.4	9.34	9.23	8.62	8.57	8.52	8.49
M	48	J_1	kgcm ²	28.1	26.6	26.3	25.2	25.1	24.4	24.3	24.3	24.3	
			10 ⁻⁴ in.lb.s ²	24.9	23.5	23.3	22.3	22.2	21.6	21.5	21.5	21.5	

Reduced mass moments of inertia available on request.

^{a)} Other ratios available on request

^{b)} For higher ambient temperatures, please reduce input speed

^{c)} Valid for clamping hub diameter of 38 mm

^{d)} Refers to center of the output shaft or flange

View A

View B

up to 24⁴⁾ (G)
clamping hub diameter

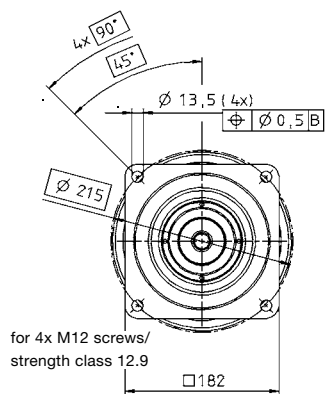

B →

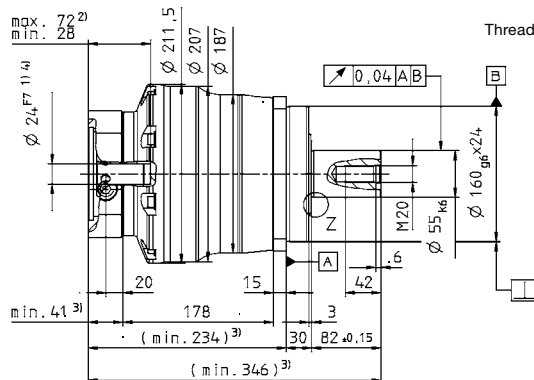

← A

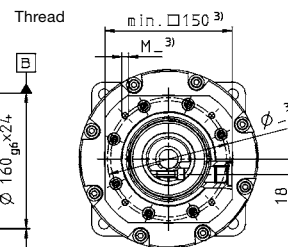

Motor shaft diameter [mm]

up to 32/38⁴⁾ (I/K)
clamping hub diameter

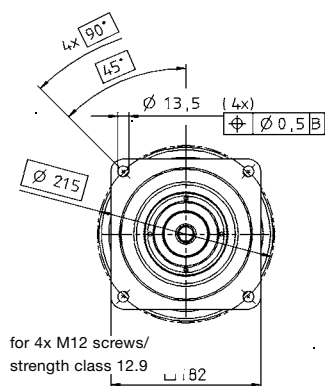

B →

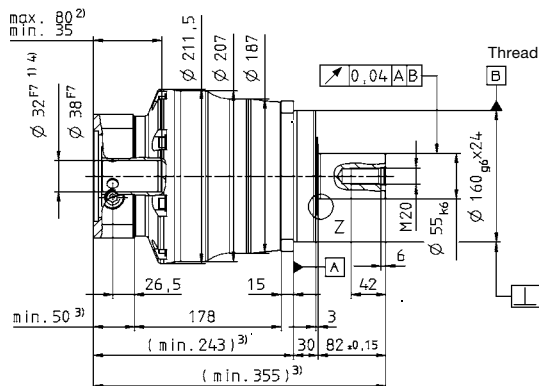

← A

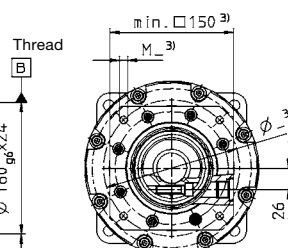

up to 48⁴⁾ (M)
clamping hub diameter

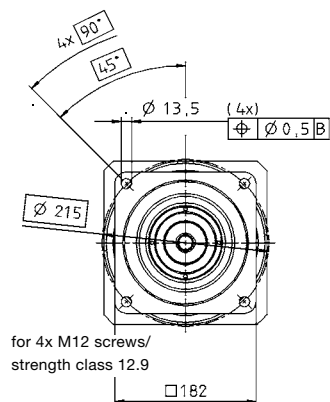

B →

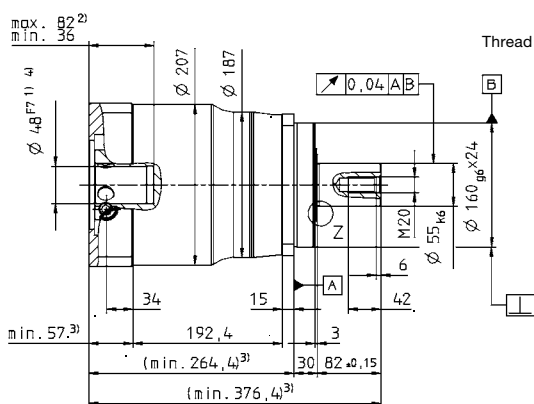

← A

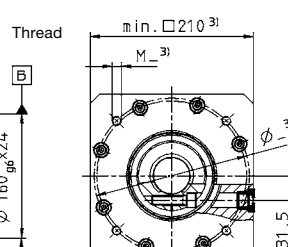

Alternatives: Output shaft variants

Keywayed output shaft in mm
E = key as per DIN 6885, sheet 1, form A

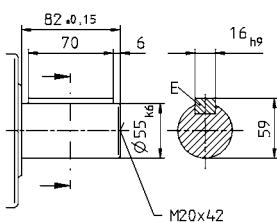

Involute gearing DIN 5480 in mm
X = W 55 x 2 x 30 x 26 x 6m, DIN 5480

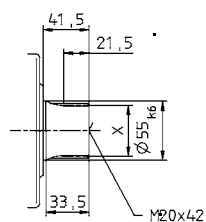

Shaft mounted
Mounted via shrink disc

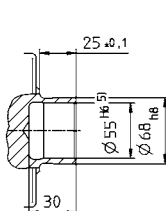

Z: Detail

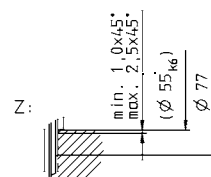

Connecting part

Non-tolerated dimensions ± 1 mm

- 1) Check motor shaft fit.
- 2) Min./Max. permissible motor shaft length.
Longer motor shafts are adaptable, please contact us.
- 3) The dimensions depend on the motor.
- 4) Smaller motor shaft diameter is compensated by a bushing with a minimum thickness of 1 mm.
- 5) Tolerance h6 for mounted shaft.

⚠ Motor mounting according to operating manual

SP:



SP+ 210 MF 1/2-stage

				1-stage					2-stage													
Ratio ^{a)}				3	4	5	7	10	16	20	25	28	35	40	50	70	100					
cymex [®] -optimized acceleration torque (please contact us regarding the design)				T_{2Bcym}	Nm in.lb		- Please contact us -															
Max. acceleration torque (max. 1000 cycles per hour)				T_{2B}	Nm in.lb	1600 14160	2500 22125	2500 22125	2400 21240	1900 16815	2400 21240	2500 22125	2500 22125	2400 21240	2400 21240	2400 21240	1900 16815					
Nominal output torque (with n_n)				T_{2N}	Nm in.lb	1100 9735	1500 13275	1500 13275	1400 12390	1000 8850	1500 13275	1500 13275	1500 13275	1500 13275	1500 13275	1500 13275	1400 12390	1000 8850				
Emergency stop torque (permitted 1000 times during the service life of the gearhead)				T_{2Not}	Nm in.lb	5000 44250	5200 46020	5200 46020	5200 46020	5000 44250	5200 46020	5200 46020	5200 46020	5200 46020	5200 46020	5200 46020	5200 46020	5000 44250				
Nominal input speed (with T_{2N} and 20°C ambient temperature) ^{b)}				n_{1N}	rpm	1200	1200	1500	1700	2000	2500	2500	2500	2500	2500	2500	3000	3000				
Max. input speed				n_{1Max}	rpm	2500	2500	2500	2500	2500	3500	3500	3500	3500	3500	3500	3500	3500				
Mean no load running torque (with $n_n=2000$ rpm and 20°C gearhead temperature)				T_{012}	Nm in.lb	32 283	22 195	17 151	11 97	7,0 62	7,0 62	6,0 53	5,5 49	4,5 40	4,0 35	3,5 31	3,5 31	3,5 31	3,0 27			
Max. torsional backlash				j_t	arcmin	Standard ≤ 3 / Reduced ≤ 1					Standard ≤ 5 / Reduced ≤ 3											
Torsional rigidity				C_{121}	Nm/arcmin in.lb/arcmin	400 3540					400 3540											
Max. axial force ^{c)}				F_{2AMax}	N lb _f	30000 6750					30000 6750											
Max. radial force ^{c)}				F_{2RMax}	N lb _f	21000 4725					21000 4725											
Max. tilting moment				M_{2KMMax}	Nm in.lb	3100 27435					3100 2744											
Efficiency at full load				η	%	97					94											
Service life (For calculation, see the Chapter "Information")				L_h	h	> 20000					> 20000											
Weight incl. standard adapter plate				m	kg lb _m	56 124					53 117											
Operating noise (with $i=10$ and $n_n=3000$ rpm no load)				L_{PA}	dB(A)	≤ 64																
Max. permitted housing temperature					°C F	+90 194																
Ambient temperature					°C F	-15 to +40 5 to 104																
Lubrication						Lubricated for life																
Paint						Blue RAL 5002																
Direction of rotation						Motor and gearhead same direction																
Protection class						IP 65																
Moment of inertia (relates to the drive)				M	48	J_1	kgcm ² 10 ⁻² in.lb.s ²	-	-	-	-	-	34.5	31.5	30.8	30.0	29.7	28.5	28.3	28.1	28.0	
Clamping hub diameter (mm)				N	55	J_1	kgcm ² 10 ⁻² in.lb.s ²	139.0	94.3	76.9	61.5	53.1	-	-	-	-	-	-	-	-	-	-

Reduced mass moments of inertia available on request.

^{a)} Other ratios available on request

^{b)} For higher ambient temperatures, please reduce input speed

^{c)} Refers to center of the output shaft or flange

1-stage:

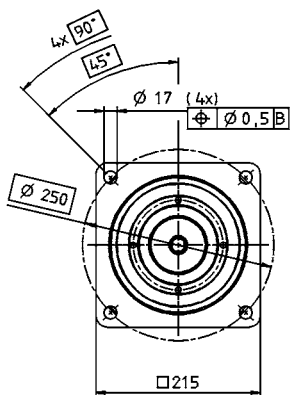

up to 55⁴⁾ (N)
clamping hub
diameter

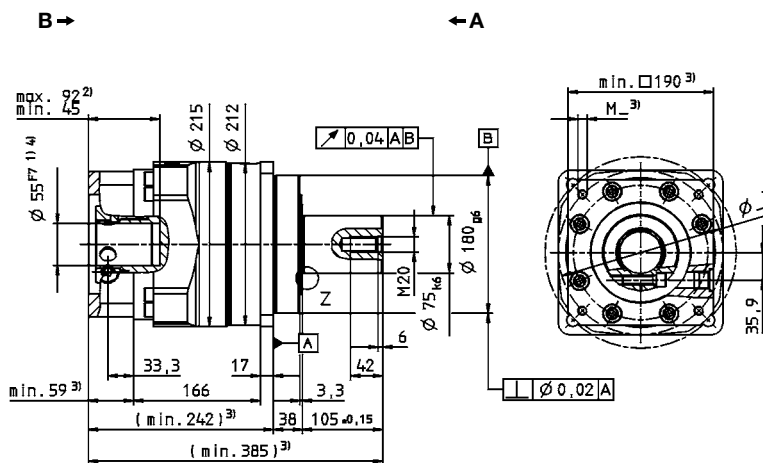

2-stage:

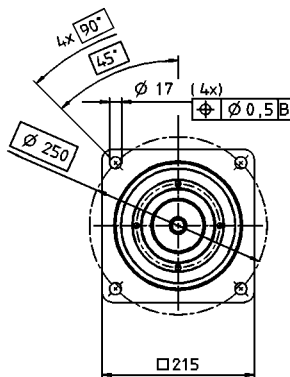

up to 48⁴⁾ (M)
clamping hub
diameter

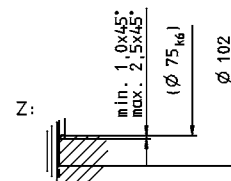
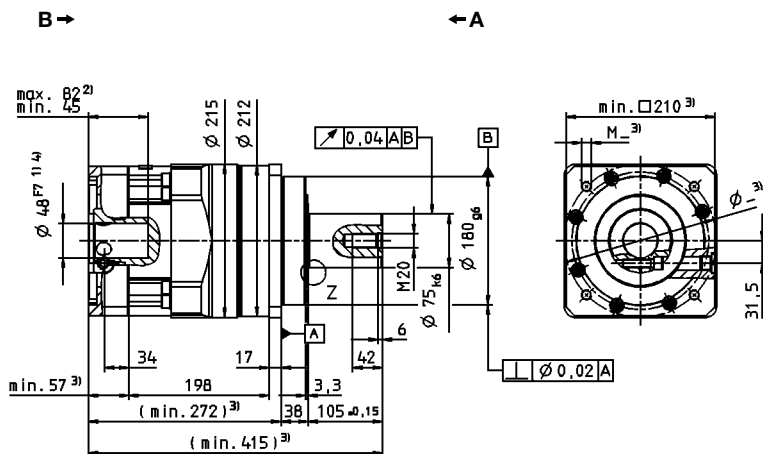

Alternatives: Output shaft variants

Keywayed output shaft in mm
E = key as per DIN 6885, sheet 1, form A

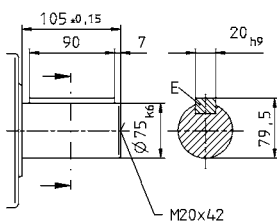

Involute gearing DIN 5480 in mm
X = W 70 x 2 x 30 x 34 x 6m, DIN 5480

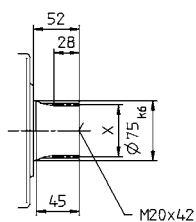

Non-tolerated dimensions ± 1.5 mm

- 1) Check motor shaft fit.
- 2) Min./Max. permissible motor shaft length.
Longer motor shafts are adaptable, please contact us.
- 3) The dimensions depend on the motor.
- 4) Smaller motor shaft diameter is compensated by a bushing with a minimum thickness of 1 mm.

⚠ Motor mounting according to operating manual



SP+ 240 MF 1/2-stage

				1-stage					2-stage										
Ratio ^{a)}		<i>i</i>		3	4	5	7	10	16	20	25	28	35	40	50	70	100		
cymex [®] -optimized acceleration torque (please contact us regarding the design)		T_{2Bcym}	Nm	- Please contact us -															
			in.lb																
Max. acceleration torque (max. 1000 cycles per hour)		T_{2B}	Nm	2750	4500	4500	4300	3400	4500	4500	4500	4500	4500	4000	4300	4300	3400		
			in.lb	24338	39825	39825	38055	30090	39825	39825	39825	39825	39825	39825	35400	38055	38055	30090	
Nominal output torque (with n_{2N})		T_{2N}	Nm	1500	2500	2500	2300	1700	2500	2500	2500	2500	2500	2500	2500	2300	1700		
			in.lb	13275	22125	22125	20355	15045	22125	22125	22125	22125	22125	22125	22125	20355	15045		
Emergency stop torque (permitted 1000 times during the service life of the gearhead)		T_{2Not}	Nm	6800	8500	8500	8500	6800	8500	8500	8500	8500	8500	8500	8500	8500	6800		
			in.lb	60180	75225	75225	75225	60180	75225	75225	75225	75225	75225	75225	75225	75225	60180		
Nominal input speed (with T_{2N} and 20°C ambient temperature) ^{b)}		n_{1N}	rpm	1000	1000	1200	1500	1700	2300	2500	2500	2500	2500	2500	2500	2800	2800		
Max. input speed		n_{1Max}	rpm	2500	2500	2500	2500	2500	3500	3500	3500	3500	3500	3500	3500	3500	3500		
Mean no load running torque (with $n_1=2000$ rpm and 20°C gearhead temperature)		T_{012}	Nm	45	35	26	16	11	11	9,0	8,0	7,0	6,0	5,0	4,5	4,0	4,0		
			in.lb	398	310	230	142	97	97	80	71	62	53	44	40	35	35		
Max. torsional backlash		j_t	arcmin	Standard ≤ 3 / Reduced ≤ 1					Standard ≤ 5 / Reduced ≤ 3										
Torsional rigidity		C_{I21}	Nm/arcmin	550					550										
			in.lb/arcmin	4868					4868										
Max. axial force ^{c)}		F_{2AMax}	N	33000					33000										
			lb _f	7425					7425										
Max. radial force ^{c)}		F_{2RMax}	N	30000					30000										
			lb _f	6750					6750										
Max. tilting moment		M_{2KMMax}	Nm	5000					5000										
			in.lb	44250					44250										
Efficiency at full load		η	%	97					94										
Service life (For calculation, see the Chapter "Information")		L_h	h	> 20000					> 20000										
Weight incl. standard adapter plate		m	kg	77					76										
			lb _m	170					168										
Operating noise (with $i=10$ and $n_1=3000$ rpm no load)		L_{PA}	dB(A)	≤ 66															
Max. permitted housing temperature			°C	+90															
			F	194															
Ambient temperature			°C	-15 to +40															
			F	5 to 104															
Lubrication				Lubricated for life															
Paint				Blue RAL 5002															
Direction of rotation				Motor and gearhead same direction															
Protection class				IP 65															
Moment of inertia (relates to the drive)		M	48	J_1	kgcm ²	-	-	-	-	-	39.2	34.6	33.2	30.5	29.7	28.2	27.9	27.6	27.5
					10 ³ in.lb.s ²	-	-	-	-	-	-	34.7	30.6	29.4	27.0	26.3	25.0	24.7	24.4
Clamping hub diameter [mm]		O	60	J_1	kgcm ²	260.2	198.2	163.0	84.4	70.8	-	-	-	-	-	-	-	-	-
					10 ³ in.lb.s ²	230.3	175.4	144.3	74.7	62.7	-	-	-	-	-	-	-	-	-

Reduced mass moments of inertia available on request.

^{a)} Other ratios available on request

^{b)} For higher ambient temperatures, please reduce input speed

^{c)} Refers to center of the output shaft or flange

Motor shaft diameter [mm]

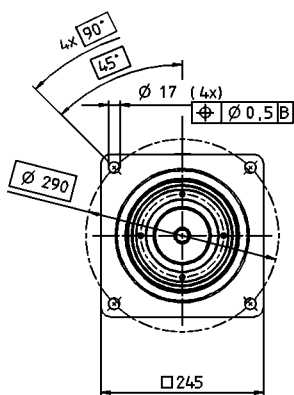
1-stage:

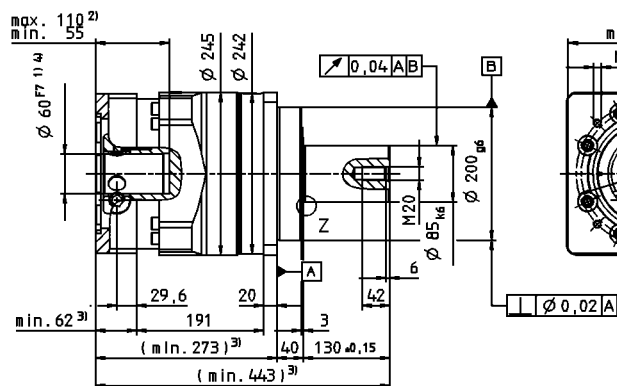
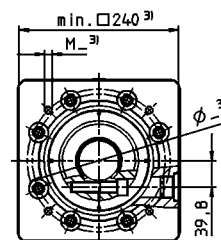
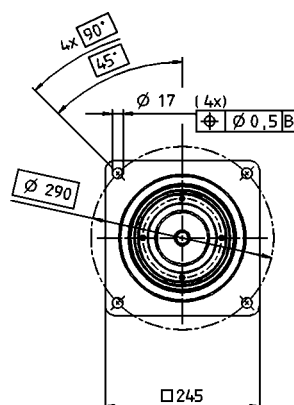
 up to 60⁴⁾ (O)
clamping hub
diameter

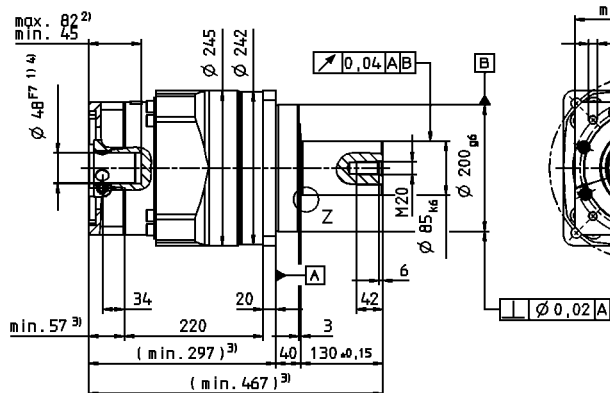
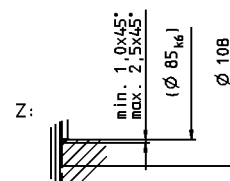
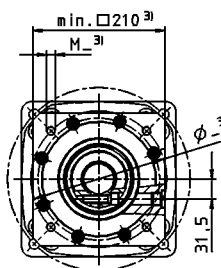
B →

← A

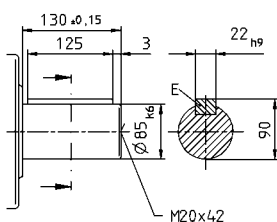
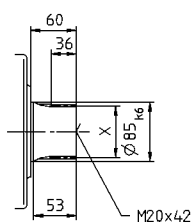
2-stage:

 up to 48⁴⁾ (M)
clamping hub
diameter

B →

← A

Alternatives: Output shaft variants

 Keywayed output shaft in mm
E = key as per DIN 6885, sheet 1, form A

 Involute gearing DIN 5480 in mm
X = W 80 x 2 x 30 x 38 x 6m, DIN 5480

Non-tolerated dimensions ± 1.5 mm

- 1) Check motor shaft fit.
- 2) Min./Max. permissible motor shaft length.
Longer motor shafts are adaptable, please contact us.
- 3) The dimensions depend on the motor.
- 4) Smaller motor shaft diameter is compensated by a bushing with a minimum thickness of 1 mm.

Motor mounting according to operating manual

SP



SP+ MC version HIGH SPEED®

Energy saving bulb in the drive

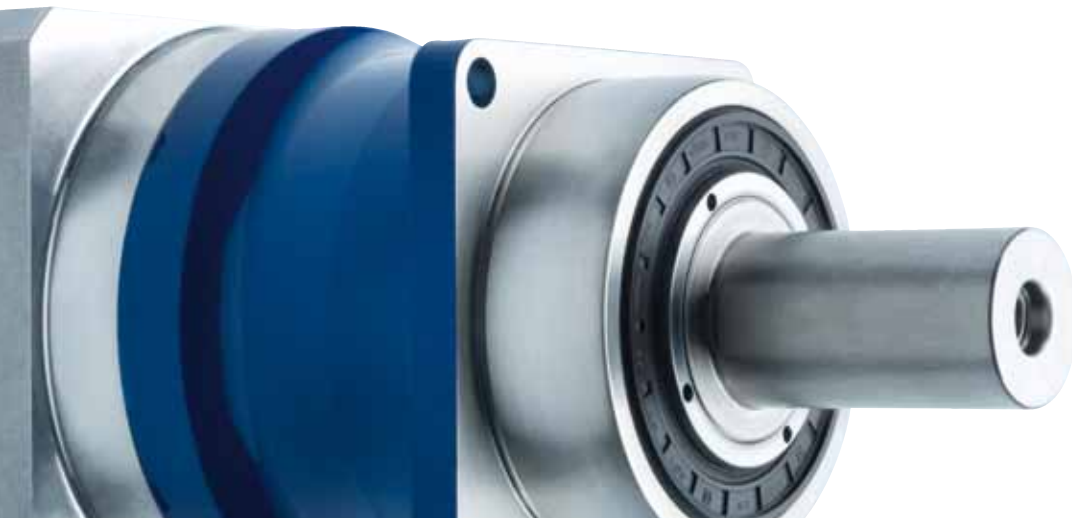

MC version HIGH SPEED®

Preferred use:

- Long duty cycles (>60%)
- High nominal speeds
- Temperature-sensitive applications
- Drive trains with high control quality

Friction optimized MC version (L)

Preferred use:

- Long duty cycles (>60%)
- Very high nominal speeds
- Highly temperature-sensitive applications
- Drive trains with high control quality
- Very low no-load running torque

SP+

Specifications \ Version	SP+ MC HIGH SPEED®		
	+	++	+++
Positioning accuracy		██████████	
Rigidity		██████████	
Smooth-running			██████████
Speed capacity			██████████
Power density		██████████	
Max. axial/radial forces		██████████	

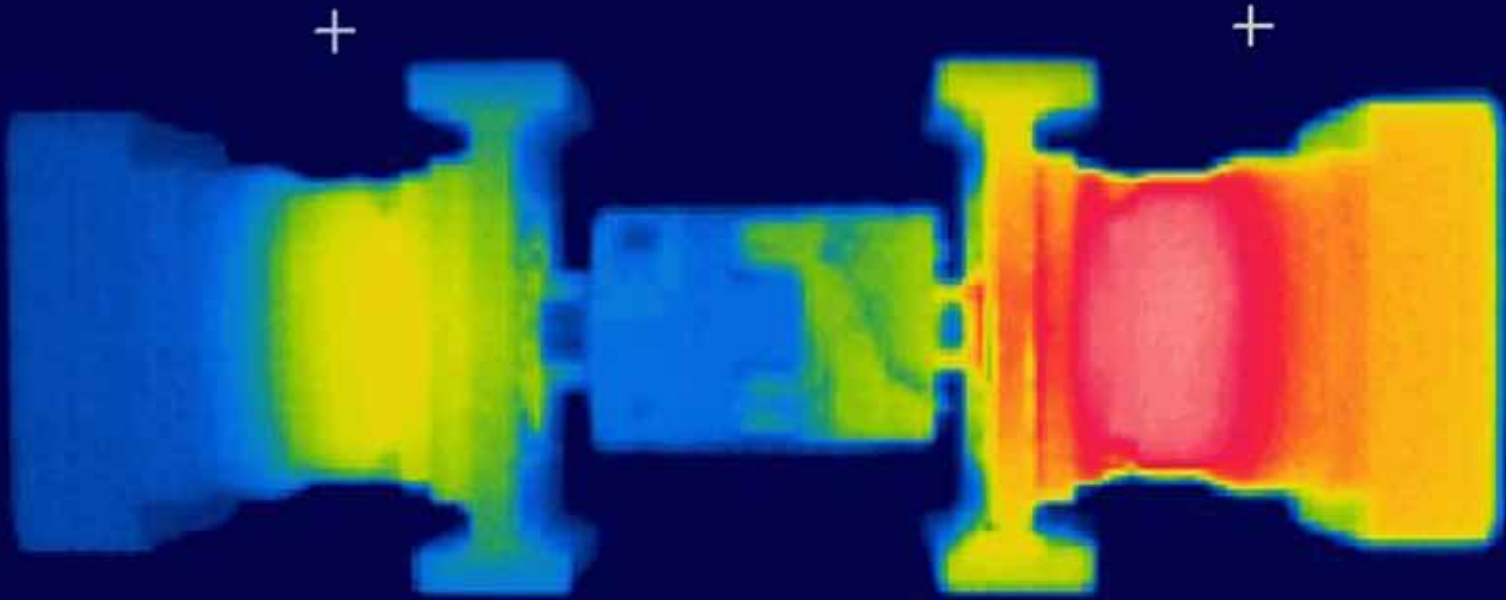

SP+ MC version HIGH SPEED®
The energy saver from WITTENSTEIN alpha

Industrial standard

Compared with conventional planetary gearheads, the SP+ HIGH SPEED® represents a significant development in efficiency. This can be illustrated directly using thermal imaging. Left: the alpha energy saver; right: a conventional industrial standard gearhead. You can see how the gearhead on the right becomes hot (due to radiated heat loss), while the SP+ HIGH SPEED® remains cool. In absolute values, this means: approx. 40 degrees Celsius (104 degrees Fahrenheit) on the left, approx. 80 degrees Celsius (176 degrees Fahrenheit) on the right.

Options

- Food-grade grease 
- Version with optimized mass moment of inertia
- L version (high nominal speed, friction optimized)

Performance data description, MC/L version

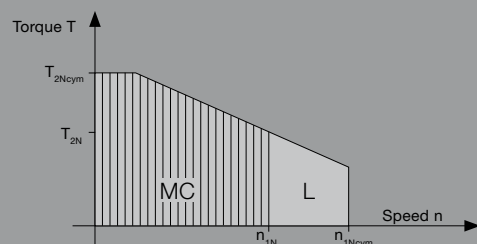

Accessories

- Rack / Pinion (see page 310)
- Shrink disc (see page 342)
- Couplings (see page 342)
- Sensor flange

SP+ 075 MC HIGH SPEED® 1-stage

				1-stage					
Ratio ^{a)}	<i>i</i>			3	4	5	7	10	
Max. acceleration torque (max. 1000 cycles per hour)	T_{2B}	Nm		68	90	90	90	70	
			in.lb	602	797	797	797	620	
cymex®-optimal nominal torque (please contact us regarding the design)	T_{2Ncym}	Nm		–	60	60	60	35	
			in.lb	–	531	531	531	310	
Nominal output torque (with n_{2N})	T_{2N}	Nm		28	48	48	48	30	
			in.lb	248	425	425	425	266	
Emergency stop torque (permitted 1000 times during the service life of the gearhead)	T_{2Not}	Nm		200	250	250	250	200	
			in.lb	1770	2213	2213	2213	1770	
Nominal input speed (with T_{2N} and 20°C ambient temperature) ^{b)}	n_{1N}	rpm		4500	4500	4500	4500	4500	
Max. input speed	n_{1Max}	rpm		6000	6000	6000	6000	6000	
Mean no load running torque (with $n_1=3000$ rpm and 20°C gearhead temperature) ^{c)}	T_{012}	Nm		1.4	1.1	0.9	0.6	0.5	
			in.lb	12.4	9.7	8.0	5.3	4.4	
Max. torsional backlash	j_t	arcmin	Standard ≤ 6 / Reduced ≤ 4						
Torsional rigidity	C_{I21}	Nm/ arcmin		10					
			in.lb/ arcmin	89					
Max. axial force ^{d)}	F_{2AMax}	N		3350					
			lb _f	754					
Max. radial force ^{d)}	F_{2RMax}	N		4200					
			lb _f	945					
Max. tilting moment	M_{2KMax}	Nm		236					
			in.lb	2089					
Efficiency at full load	η	%		98.5					
Service life (For calculation, see the Chapter "Information")	L_h	h		> 30000					
Weight incl. standard adapter plate	m	kg		3.9					
			lb _m	8.6					
Operating noise (with $i=10$ and $n_1=3000$ rpm no load)	L_{PA}	dB(A)		≤ 59					
Max. permitted housing temperature			°C	+90					
			F	194					
Ambient temperature			°C	-15 to +40					
			F	5 to 104					
Lubrication				Lubricated for life					
Paint				Blue RAL 5002					
Direction of rotation				Motor and gearhead same direction					
Protection class				IP 65					
Moment of inertia (relates to the drive)	E	19	J_1	kgcm ²	1.03	0.78	0.68	0.59	0.54
				10 ⁻⁴ in.lb.s ²	0.91	0.69	0.60	0.52	0.48
Clamping hub diameter [mm]	G	24	J_1	kgcm ²	2.40	2.15	2.05	1.96	1.91
				10 ⁻⁴ in.lb.s ²	2.12	1.90	1.81	1.73	1.69

Reduced mass moments of inertia available on request.

^{a)} Other ratios available on request

^{b)} For higher ambient temperatures, please reduce input speed

^{c)} Valid for clamping hub diameter of 19 mm

^{d)} Refers to centre of the output shaft or flange

View A

View B

Motor shaft diameter [mm]

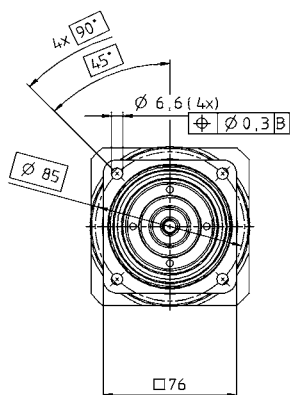
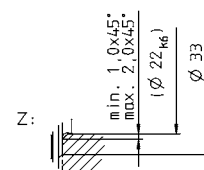
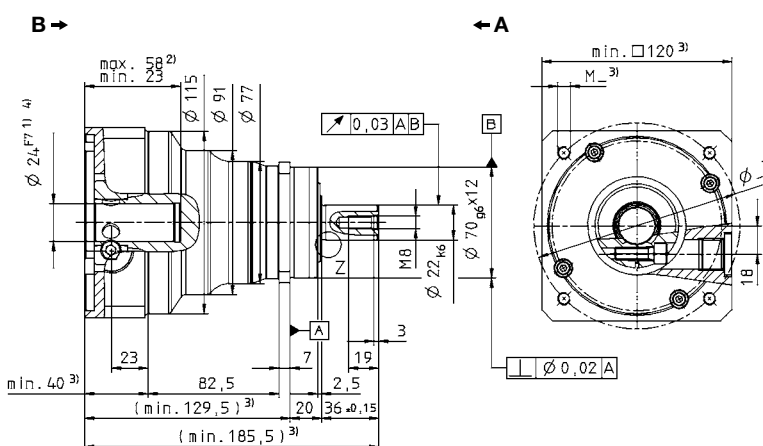
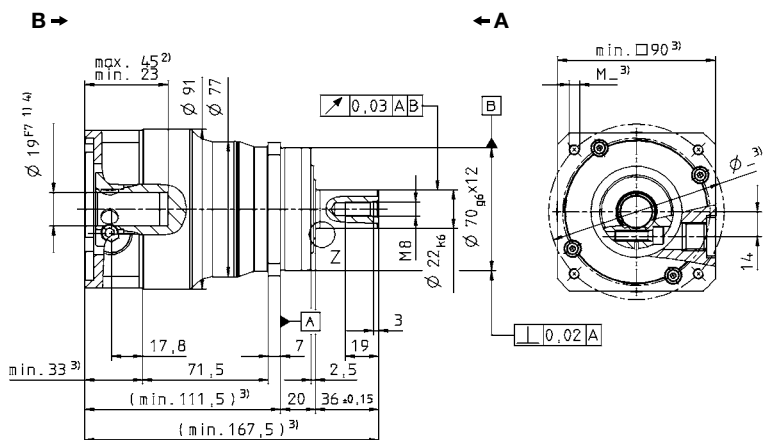
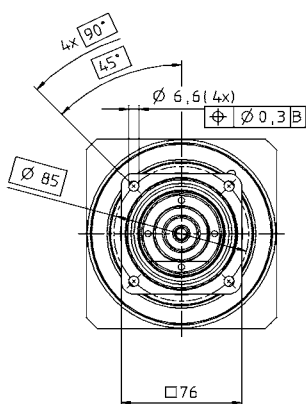
up to 19⁴⁾ (E)
clamping hub diameterup to 24⁴⁾ (G)
clamping hub diameter

Alternatives: Output shaft variants

Keywayed output shaft in mm
E = key as per DIN 6885, sheet 1, form A

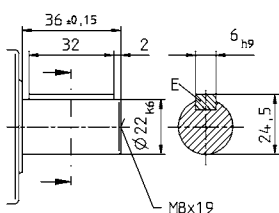

Involute gearing DIN 5480 in mm
X = W 22 x 1.25 x 30 x 16 x 6m, DIN 5480

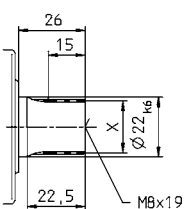

Shaft mounted
Mounted via shrink disc

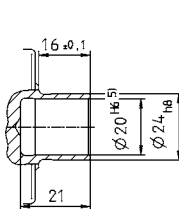

Non-tolerated dimensions ± 1 mm

- 1) Check motor shaft fit.
- 2) Min./Max. permissible motor shaft length.
Longer motor shafts are adaptable, please contact us.
- 3) The dimensions depend on the motor.
- 4) Smaller motor shaft diameter is compensated by a bushing with a minimum thickness of 1 mm.
- 5) Tolerance h6 for mounted shaft.

Motor mounting according to operating manual

SP



SP+ 075 MC HIGH SPEED® 2-stage

				2-stage									
Ratio ^{a)}	<i>i</i>			16	20	25	28	35	40	50	70	100	
Max. acceleration torque (max. 1000 cycles per hour)	T_{2B}	Nm	in.lb	90	90	90	90	90	90	90	90	70	
				797	797	797	797	797	797	797	797	620	
cymex®-optimal nominal torque (please contact us regarding the design)	T_{2Ncym}	Nm	in.lb	-	-	-	-	-	60	-	-	35	
									531			310	
Nominal output torque (with n_{2N})	T_{2N}	Nm	in.lb	60	60	60	60	60	55	60	60	30	
				531	531	531	531	531	487	531	531	266	
Emergency stop torque (permitted 1000 times during the service life of the gearhead)	T_{2Not}	Nm	in.lb	250	250	250	250	250	250	250	250	200	
				2213	2213	2213	2213	2213	2213	2213	2213	1770	
Nominal input speed (with T_{2N} and 20°C ambient temperature) ^{b)}	n_{1N}	rpm		4500	4500	4500	4500	4500	4500	4500	4500	4500	
Max. input speed	n_{1Max}	rpm		6000	6000	6000	6000	6000	6000	6000	6000	6000	
Mean no load running torque (with $n_1=3000$ rpm and 20°C gearhead temperature) ^{c)}	T_{012}	Nm	in.lb	0.5	0.4	0.4	0.3	0.3	0.2	0.2	0.2	0.2	
				4.4	3.5	3.5	2.7	2.7	1.8	1.8	1.8	1.8	
Max. torsional backlash	j_t	arcmin	Standard ≤ 8 / Reduced ≤ 6										
Torsional rigidity	C_{I21}	Nm/ arcmin	in.lb/ arcmin	10									
				89									
Max. axial force ^{d)}	F_{2AMax}	N	lb _f	3350									
				754									
Max. radial force ^{d)}	F_{2RMMax}	N	lb _f	4200									
				945									
Max. tilting moment	M_{2KMax}	Nm	in.lb	236									
				2089									
Efficiency at full load	η	%	96,5										
Service life (For calculation, see the Chapter "Information")	L_h	h	> 30000										
Weight incl. standard adapter plate	m	kg	lb _m	3,6									
				8,0									
Operating noise (with $i=100$ and $n_1=3000$ rpm no load)	L_{PA}	dB(A)	≤ 59										
Max. permitted housing temperature		°C	F	+90									
				194									
Ambient temperature		°C	F	-15 to +40									
				5 to 104									
Lubrication	Lubricated for life												
Paint	Blue RAL 5002												
Direction of rotation	Motor and gearhead same direction												
Protection class	IP 65												
Moment of inertia (relates to the drive)	C	14	J_1	kgcm ²	0.23	0.20	0.20	0.18	0.18	0.16	0.16	0.16	0.16
				10 ⁻⁴ in.lb.s ²	0.20	0.18	0.18	0.16	0.16	0.15	0.15	0.14	0.14
Clamping hub diameter [mm]	E	19	J_1	kgcm ²	0.55	0.53	0.52	0.50	0.50	0.49	0.49	0.49	0.49
				10 ⁻⁴ in.lb.s ²	0.49	0.47	0.46	0.45	0.44	0.43	0.43	0.43	0.43

Reduced mass moments of inertia available on request.

^{a)} Other ratios available on request

^{b)} For higher ambient temperatures, please reduce input speed

^{c)} Valid for clamping hub diameter of 14 mm

^{d)} Refers to centre of the output shaft or flange

View A

View B

Motor shaft diameter [mm]

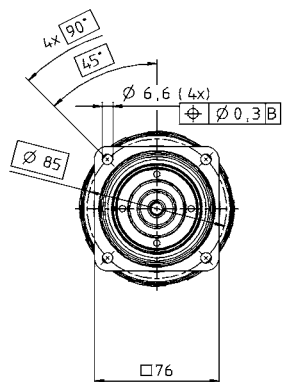
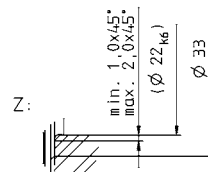
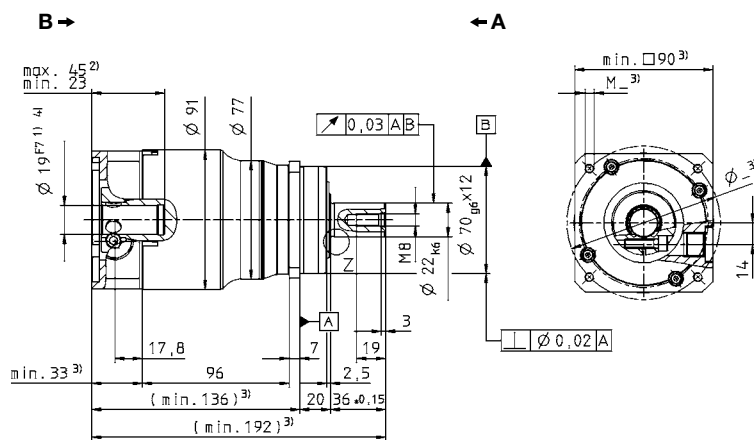
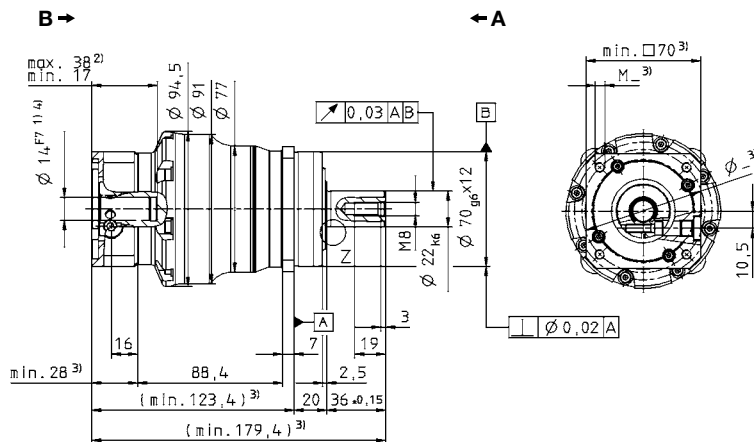
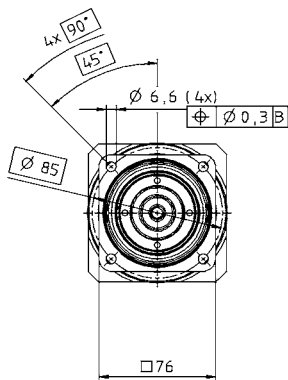
 up to 14⁴⁾ (C)
clamping hub diameter

 up to 19⁴⁾ (E)
clamping hub diameter

Alternatives: Output shaft variants

 Keywayed output shaft in mm
E = key as per DIN 6885, sheet 1, form A

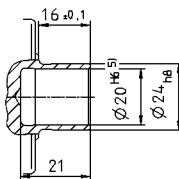
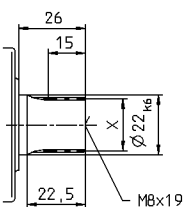
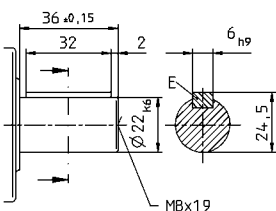
 Involute gearing DIN 5480 in mm
X = W 22 x 1.25 x 30 x 16 x 6m, DIN 5480

 Shaft mounted
Mounted via shrink disc

Non-tolerated dimensions ± 1 mm

- 1) Check motor shaft fit.
- 2) Min./Max. permissible motor shaft length.
Longer motor shafts are adaptable, please contact us.
- 3) The dimensions depend on the motor.
- 4) Smaller motor shaft diameter is compensated by a bushing with a minimum thickness of 1 mm.
- 5) Tolerance h6 for mounted shaft.

Motor mounting according to operating manual

SP



SP+ 100 MC HIGH SPEED® 1-stage

Ratio ^{a)}			<i>i</i>	Standard version MC					Friction optimized version L					
				3	4	5	7	10	3	4	5	7	10	
Max. acceleration torque (max. 1000 cycles per hour)	T_{2B}	Nm	180	240	240	240	180	180	240	240	240	180		
		in.lb	1593	2124	2124	2124	1593	1593	2124	2124	2124	1593		
cymex®-optimal nominal torque (please contact us regarding the design)	T_{2Ncym}	Nm	95	135	135	135	90	95	135	135	135	90		
		in.lb	841	1195	1195	1195	797	841	1195	1195	1195	797		
Nominal output torque (with n_{1N})	T_{2N}	Nm	70	100	105	105	80	70	100	105	105	80		
		in.lb	620	885	929	929	708	620	885	929	929	708		
Emergency stop torque (permitted 1000 times during the service life of the gearhead)	T_{2Not}	Nm	500	625	625	625	500	500	625	625	625	500		
		in.lb	4425	5531	5531	5531	4425	4425	5531	5531	5531	4425		
Nominal input speed (with T_{2N} and 20°C ambient temperature) ^{b)}	n_{1N}	rpm	3500	4000	4500	4500	4500	3500	4000	4500	4500	4500		
cymex® optimized speed (please contact us regarding the design)	n_{1Ncym}	rpm	-	-	-	-	-	4500	5000	5000	5000	5000		
Max. input speed	n_{1Max}	rpm	6000	6000	6000	6000	6000	6000	6000	6000	6000	6000		
Mean no load running torque (with $n_1=3000$ rpm and 20°C gearhead temperature) ^{c)}	T_{012}	Nm	2.4	2.1	1.8	1.1	0.8	0.7	-	-	-	-		
		in.lb	21.2	18.6	15.9	9.74	7.08	6.2	-	-	-	-		
Max. torsional backlash	j_t	arcmin	Standard ≤ 4 / Reduced ≤ 2											
Torsional rigidity	C_{t21}	Nm/ arcmin	31											
		in.lb/ arcmin	274											
Max. axial force ^{d)}	F_{2AMax}	N	5650					-						
		lb _f	1271					-						
Max. radial force ^{d)}	F_{2RMax}	N	6600					1000						
		lb _f	1485					225						
Max. tilting moment	M_{2KMax}	Nm	487					72						
		in.lb	4310					637						
Efficiency at full load	η	%	98.5					99						
Service life (For calculation, see the Chapter "Information")	L_h	h	> 30000											
Weight incl. standard adapter plate	m	kg	7.7											
		lb _m	17.0											
Operating noise (with $i=10$ and $n_1=3000$ rpm no load)	L_{PA}	dB(A)	≤ 64											
Max. permitted housing temperature		°C	+90											
		F	194											
Ambient temperature		°C	-15 to +40											
		F	5 to 104											
Lubrication			Lubricated for life											
Paint			Blue RAL 5002											
Direction of rotation			Motor and gearhead same direction											
Protection class			IP 65					IP 52						
Moment of inertia (relates to the drive)	G	24	J_1	kgcm ²	3.99	3.04	2.61	2.29	2.07	3.99	3.04	2.61	2.29	2.07
				10 ⁻³ in.lb.s ²	3.53	2.69	2.31	2.03	1.83	3.53	2.69	2.31	2.03	1.83
Clamping hub diameter [mm]	K	38	J_1	kgcm ²	11.1	10.1	9.68	9.36	9.14	11.1	10.1	9.68	9.36	9.14
				10 ⁻³ in.lb.s ²	9.78	8.95	8.57	8.28	8.09	9.78	8.95	8.57	8.28	8.09

Reduced mass moments of inertia available on request.

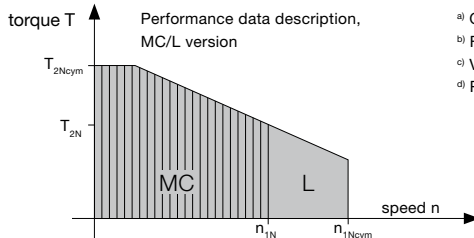

- ^{a)} Other ratios available on request
- ^{b)} For higher ambient temperatures, please reduce input speed
- ^{c)} Valid for clamping hub diameter of 24 mm
- ^{d)} Refers to centre of the output shaft or flange

View A

View B

Motor shaft diameter [mm]

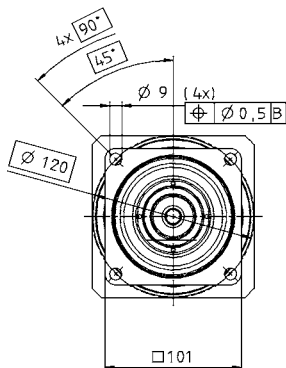
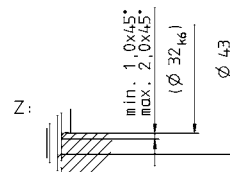
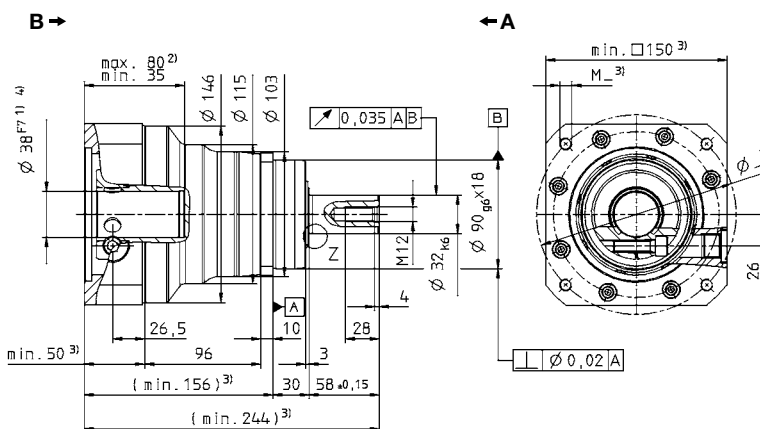
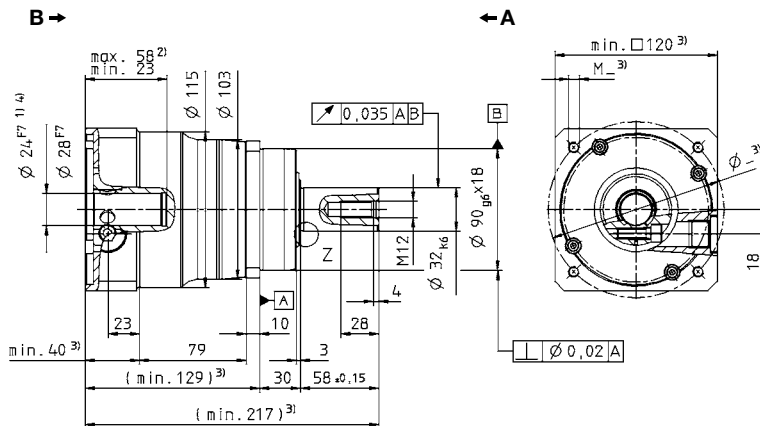
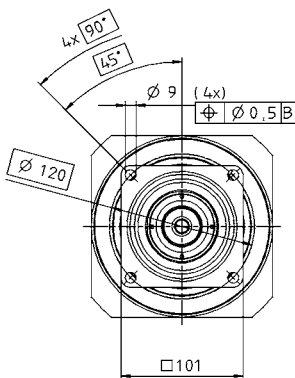
 up to 24⁴⁾(G)
clamping hub diameter

 up to 38⁴⁾(K)
clamping hub diameter

Alternatives: Output shaft variants

 Keywayed output shaft in mm
E = key as per DIN 6885, sheet 1, form A

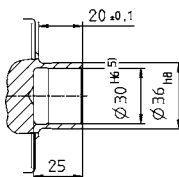
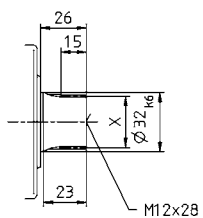
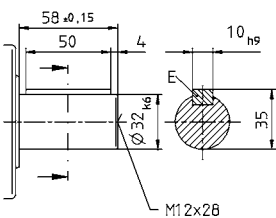
 Involute gearing DIN 5480 in mm
X = W 32 x 1.25 x 30 x 24 x 6m, DIN 5480

 Shaft mounted
Mounted via shrink disc

Non-tolerated dimensions ± 1 mm

- 1) Check motor shaft fit.
- 2) Min./Max. permissible motor shaft length.
Longer motor shafts are adaptable, please contact us.
- 3) The dimensions depend on the motor.
- 4) Smaller motor shaft diameter is compensated by a bushing with a minimum thickness of 1 mm.
- 5) Tolerance h6 for mounted shaft.

Motor mounting according to operating manual

SP



SP+ 100 MC HIGH SPEED® 2-stage

				2-stage									
Ratio ^{a)}		<i>i</i>		16	20	25	28	35	40	50	70	100	
Max. acceleration torque (max. 1000 cycles per hour)	T_{2B}	Nm		240	240	240	240	240	240	240	240	180	
			in.lb	2124	2124	2124	2124	2124	2124	2124	2124	1593	
cymex®-optimal nominal torque (please contact us regarding the design)	T_{2Ncym}	Nm		-	-	-	-	-	-	-	-	90	
			in.lb										797
Nominal output torque (with n_{2N})	T_{2N}	Nm		140	140	140	140	140	140	140	135	80	
			in.lb	1239	1239	1239	1239	1239	1239	1239	1195	708	
Emergency stop torque (permitted 1000 times during the service life of the gearhead)	T_{2Not}	Nm		625	625	625	625	625	625	625	625	500	
			in.lb	5531	5531	5531	5531	5531	5531	5531	5531	4425	
Nominal input speed (with T_{2N} and 20°C ambient temperature) ^{b)}	n_{1N}	rpm		4500	4500	4500	4500	4500	4500	4500	4500	4500	
Max. input speed	n_{1Max}	rpm		6000	6000	6000	6000	6000	6000	6000	6000	6000	
Mean no load running torque (with $n_1=3000$ rpm and 20°C gearhead temperature) ^{c)}	T_{012}	Nm		0.8	0.7	0.6	0.5	0.4	0.4	0.3	0.3	0.3	
			in.lb	7.1	6.2	5.3	4.4	3.5	3.5	2.7	2.7	2.7	
Max. torsional backlash	j_t	arcmin		Standard ≤ 6 / Reduced ≤ 4									
Torsional rigidity	C_{I21}	Nm/ arcmin		31									
			in.lb/ arcmin	274									
Max. axial force ^{d)}	F_{2AMax}	N		5650									
			lb _f	1271									
Max. radial force ^{d)}	F_{2RMMax}	N		6600									
			lb _f	1485									
Max. tilting moment	M_{2KMax}	Nm		487									
			in.lb	4310									
Efficiency at full load	η	%		96.5									
Service life (For calculation, see the Chapter "Information")	L_h	h		> 30000									
Weight incl. standard adapter plate	m	kg		7.9									
			lb _m	17.5									
Operating noise (with $i=100$ and $n_1=3000$ rpm no load)	L_{PA}	dB(A)		≤ 60									
Max. permitted housing temperature		°C		+90									
			F	194									
Ambient temperature		°C		-15 to +40									
			F	5 to 104									
Lubrication				Lubricated for life									
Paint				Blue RAL 5002									
Direction of rotation				Motor and gearhead same direction									
Protection class				IP 65									
Moment of inertia (relates to the drive)	E	19	J_1	kgcm ²	0.81	0.70	0.69	0.60	0.59	0.55	0.54	0.54	0.54
				10 ⁻³ in.lb.s ²	0.72	0.62	0.61	0.53	0.52	0.48	0.48	0.48	0.48
Clamping hub diameter [mm]	G	24	J_1	kgcm ²	2.18	2.07	2.05	1.97	1.96	1.92	1.91	1.91	1.91
				10 ⁻³ in.lb.s ²	1.93	1.83	1.82	1.74	1.74	1.70	1.69	1.69	1.69

Reduced mass moments of inertia available on request.

^{a)} Other ratios available on request

^{b)} For higher ambient temperatures, please reduce input speed

^{c)} Valid for clamping hub diameter of 19 mm

^{d)} Refers to centre of the output shaft or flange

View A

View B

Motor shaft diameter [mm]

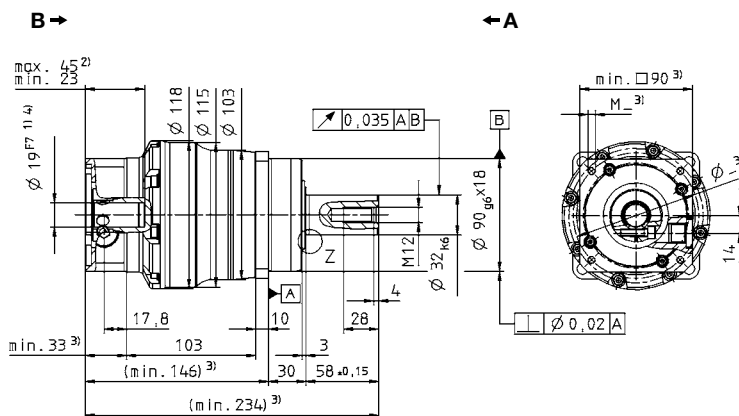
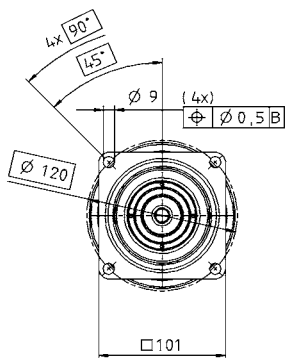
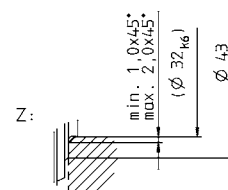
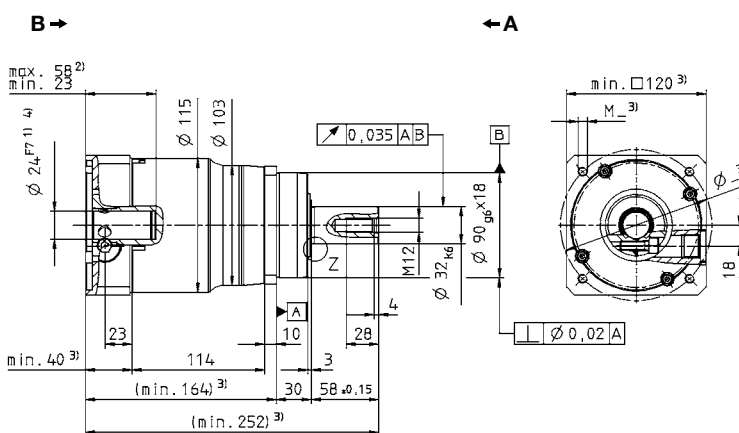
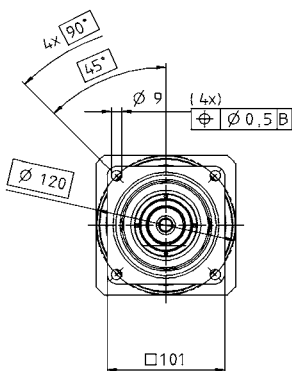
 up to 19⁴⁾ (E)
clamping hub diameter

 up to 24⁴⁾ (G)
clamping hub diameter

Alternatives: Output shaft variants

Keywayed output shaft in mm
 E = key as per DIN 6885, sheet 1, form A

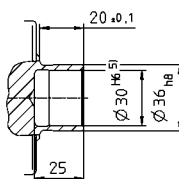
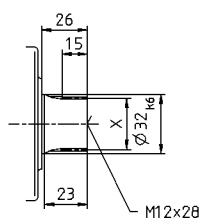
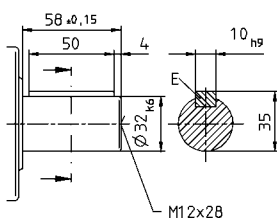
Involute gearing DIN 5480 in mm
 X = W 32 x 1.25 x 30 x 24 x 6m, DIN 5480

Shaft mounted
 Mounted via shrink disc

Non-tolerated dimensions ± 1 mm

- 1) Check motor shaft fit.
- 2) Min./Max. permissible motor shaft length.
Longer motor shafts are adaptable, please contact us.
- 3) The dimensions depend on the motor.
- 4) Smaller motor shaft diameter is compensated by a bushing with a minimum thickness of 1 mm.
- 5) Tolerance h6 for mounted shaft.

Motor mounting according to operating manual

SP



SP+ 140 MC HIGH SPEED® 1-stage

Ratio ^{a)}			<i>i</i>	Standard version MC					Friction optimized version L				
				3	4	5	7	10	3	4	5	7	10
Max. acceleration torque (max. 1000 cycles per hour)	T_{2B}	Nm	310	480	480	480	380	310	480	480	480	380	
		in.lb	2744	4248	4248	4248	3363	2744	4248	4248	4248	3363	
cymex®-optimal nominal torque (please contact us regarding the design)	T_{2Ncym}	Nm	150	240	240	270	180	150	240	240	270	180	
		in.lb	1328	2124	2124	2390	1593	2744	4248	4248	4248	3363	
Nominal output torque (with n_{1N})	T_{2N}	Nm	130	195	205	210	160	130	195	205	210	160	
		in.lb	1151	1726	1814	1859	1416	1151	1726	1814	1859	1416	
Emergency stop torque (permitted 1000 times during the service life of the gearhead)	T_{2Not}	Nm	1000	1250	1250	1250	1000	1000	1250	1250	1250	1000	
		in.lb	8850	11063	11063	11063	8850	8850	11063	11063	11063	8850	
Nominal input speed (with T_{2N} and 20°C ambient temperature) ^{b)}	n_{1N}	rpm	3000	3500	4500	4500	4500	3000	3500	4500	4500	4500	
cymex® optimized speed (please contact us regarding the design)	n_{1Ncym}	rpm	-	-	-	-	-	4000	4500	5000	5000	5000	
Max. input speed	n_{1Max}	rpm	6000	6000	6000	6000	6000	6000	6000	6000	6000	6000	
Mean no load running torque (with $n_1=3000$ rpm and 20°C gearhead temperature) ^{c)}	T_{012}	Nm	5.1	3.9	3.1	2.3	1.6	1.0	-	-	-	-	
		in.lb	45.1	34.5	27.4	20.4	14.2	8.9	-	-	-	-	
Max. torsional backlash	j_t	arcmin	Standard ≤ 4 / Reduced ≤ 2										
Torsional rigidity	C_{t21}	Nm/ arcmin	53										
		in.lb/ arcmin	469										
Max. axial force ^{d)}	F_{2AMax}	N	9870					-					
		lb _f	2221					-					
Max. radial force ^{d)}	F_{2RMax}	N	9900					1200					
		lb _f	2228					270					
Max. tilting moment	M_{2KMax}	Nm	952					110					
		in.lb	8425					974					
Efficiency at full load	η	%	98.5					99					
Service life (For calculation, see the Chapter "Information")	L_h	h	> 30000										
Weight incl. standard adapter plate	m	kg	17.2										
		lb _m	38										
Operating noise (with $i=10$ and $n_1=3000$ rpm no load)	L_{pA}	dB(A)	≤ 65										
Max. permitted housing temperature		°C	+90										
		F	194										
Ambient temperature		°C	-15 to +40										
		F	5 to 104										
Lubrication			Lubricated for life										
Paint			Blue RAL 5002										
Direction of rotation			Motor and gearhead same direction										
Protection class			IP 65					IP 52					
Moment of inertia (relates to the drive)	K 38	J_1	kgcm ²	14.9	12.1	11.0	10.1	9.51	14.9	12.1	11.0	10.1	9.51
			10 ⁻³ in.lb.s ²	13.2	10.7	9.8	8.9	8.4	13.2	10.7	9.8	8.9	8.4
Clamping hub diameter [mm]	M 48	J_1	kgcm ²	29.5	26.7	25.6	24.7	24.2	29.5	26.7	25.6	24.7	24.2
			10 ⁻³ in.lb.s ²	26.1	23.6	22.7	21.9	21.4	26.1	23.6	22.7	21.9	21.4

Reduced mass moments of inertia available on request.

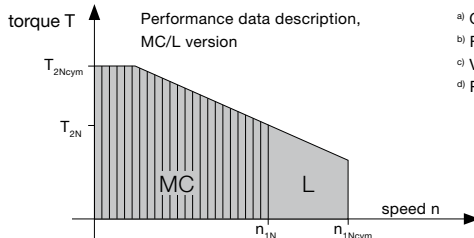

^{a)} Other ratios available on request

^{b)} For higher ambient temperatures, please reduce input speed

^{c)} Valid for clamping hub diameter of 38 mm

^{d)} Refers to center of the output shaft or flange

View A

View B

Motor shaft diameter [mm]

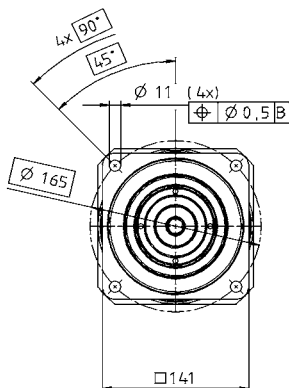
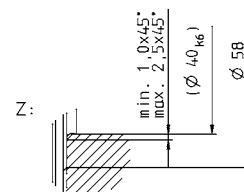
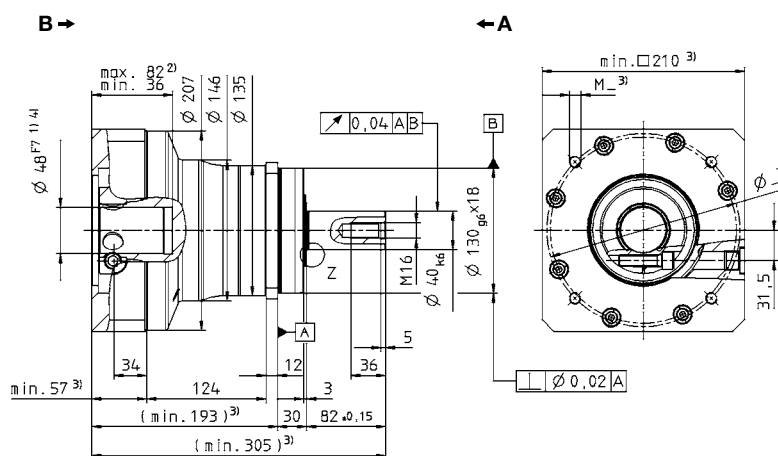
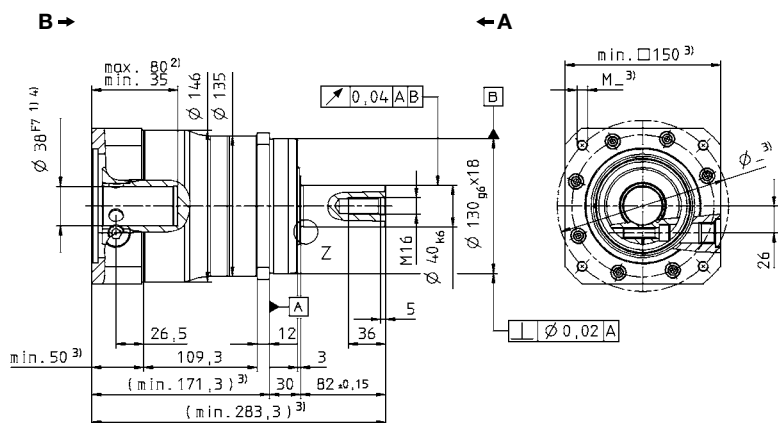
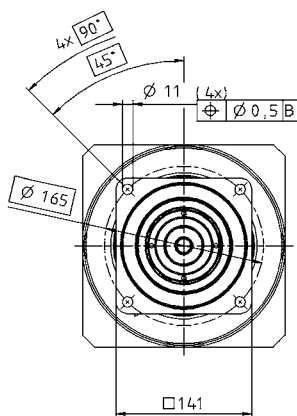
up to 38⁴⁾ (K)
clamping hub diameterup to 48⁴⁾ (M)
clamping hub diameter

Alternatives: Output shaft variants

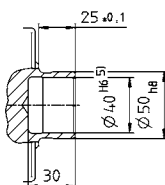
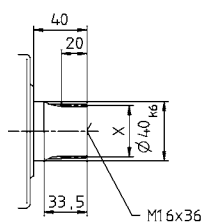
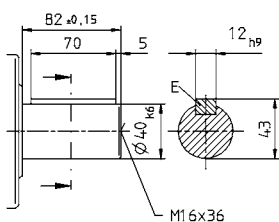
Keywayed output shaft in mm
E = key as per DIN 6885, sheet 1, form AInvolute gearing DIN 5480 in mm
X = W 40 x 2 x 30 x 18 x 6m, DIN 5480Shaft mounted
Mounted via shrink disc

Non-tolerated dimensions ± 1 mm

- 1) Check motor shaft fit.
- 2) Min./Max. permissible motor shaft length.
Longer motor shafts are adaptable, please contact us.
- 3) The dimensions depend on the motor.
- 4) Smaller motor shaft diameter is compensated by a bushing with a minimum thickness of 1 mm.
- 5) Tolerance h6 for mounted shaft.

Motor mounting according to operating manual

SP:



SP+ 140 MC HIGH SPEED® 2-stage

				2-stage									
Ratio ^{a)}	<i>i</i>			16	20	25	28	35	40	50	70	100	
Max. acceleration torque (max. 1000 cycles per hour)	T_{2B}	Nm		480	480	480	480	480	480	480	480	380	
			in.lb	4248	4248	4248	4248	4248	4248	4248	4248	3363	
cymex®-optimal nominal torque (please contact us regarding the design)	T_{2Ncym}	Nm		290	290	290	-	-	-	-	-	-	
			in.lb	2567	2567	2567							
Nominal output torque (with n_{2N})	T_{2N}	Nm		260	280	280	290	290	290	290	260	180	
			in.lb	2301	2478	2478	2567	2567	2567	2567	2301	1593	
Emergency stop torque (permitted 1000 times during the service life of the gearhead)	T_{2Not}	Nm		1250	1250	1250	1250	1250	1250	1250	1250	1000	
			in.lb	11063	11063	11063	11063	11063	11063	11063	11063	8850	
Nominal input speed (with T_{2N} and 20°C ambient temperature) ^{b)}	n_{1N}	rpm		4500	4500	4500	4500	4500	4500	4500	4500	4500	
Max. input speed	n_{1Max}	rpm		6000	6000	6000	6000	6000	6000	6000	6000	6000	
Mean no load running torque (with $n_1=3000$ rpm and 20°C gearhead temperature) ^{c)}	T_{012}	Nm		1.6	1.3	1.2	1.0	0.9	0.7	0.6	0.5	0.5	
			in.lb	14.2	11.5	10.6	8.9	8.0	6.2	5.3	4.4	4.4	
Max. torsional backlash	j_t	arcmin		Standard ≤ 6 / Reduced ≤ 4									
Torsional rigidity	C_{I21}	Nm/ arcmin		53									
			in.lb/ arcmin	469									
Max. axial force ^{d)}	F_{2AMax}	N		9870									
			lb _f	2221									
Max. radial force ^{d)}	F_{2RMMax}	N		9900									
			lb _f	2228									
Max. tilting moment	M_{2KMax}	Nm		952									
			in.lb	8425									
Efficiency at full load	η	%		96.5									
Service life (For calculation, see the Chapter "Information")	L_h	h		> 30000									
Weight incl. standard adapter plate	<i>m</i>	kg		17									
			lb _m	38									
Operating noise (with $i=100$ and $n_1=3000$ rpm no load)	L_{PA}	dB(A)		≤ 63									
Max. permitted housing temperature		°C		+90									
			F	194									
Ambient temperature		°C		-15 to +40									
			F	5 to 104									
Lubrication				Lubricated for life									
Paint				Blue RAL 5002									
Direction of rotation				Motor and gearhead same direction									
Protection class				IP 65									
Moment of inertia (relates to the drive)	G	24	J_1	kgcm ²	3.19	2.71	2.67	2.34	2.32	2.10	2.08	2.08	2.07
				10 ⁻⁴ in.lb.s ²	2.82	2.40	2.36	2.07	2.05	1.85	1.85	1.84	1.83
Clamping hub diameter [mm]	K	38	J_1	kgcm ²	10.3	9.77	9.73	9.41	9.39	9.16	9.15	9.14	9.14
				10 ⁻⁴ in.lb.s ²	9.07	8.65	8.61	8.33	8.31	8.11	8.10	8.09	8.09

Reduced mass moments of inertia available on request.

^{a)} Other ratios available on request

^{b)} For higher ambient temperatures, please reduce input speed

^{c)} Valid for clamping hub diameter of 24 mm

^{d)} Refers to center of the output shaft or flange

View A

View B

Motor shaft diameter [mm]

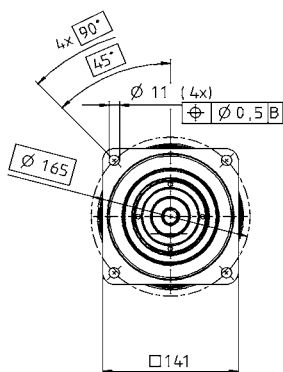
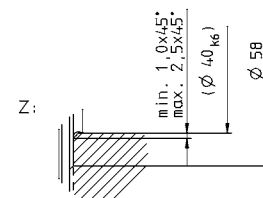
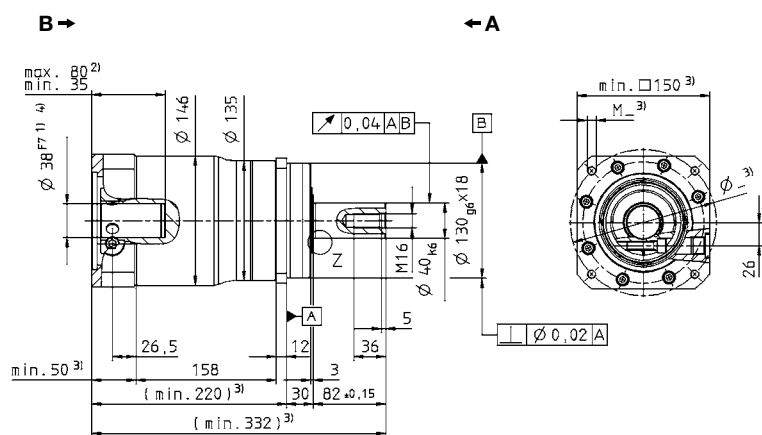
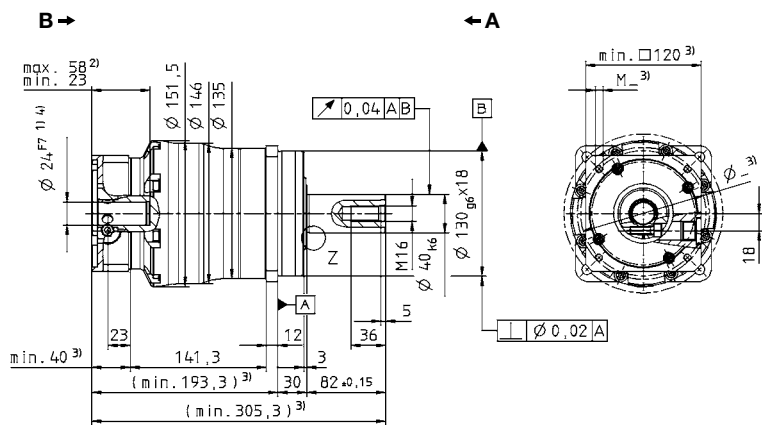
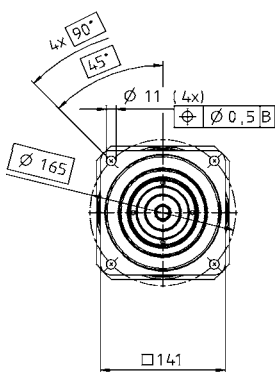
up to 24⁴⁾ (G)
clamping hub diameterup to 38⁴⁾ (K)
clamping hub diameter

Alternatives: Output shaft variants

Keywayed output shaft in mm
E = key as per DIN 6885, sheet 1, form A

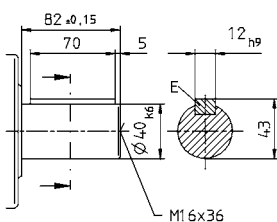

Involute gearing DIN 5480 in mm
X = W 40 x 2 x 30 x 18 x 6m, DIN 5480

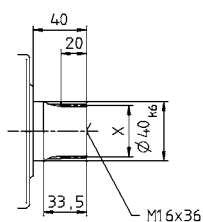

Shaft mounted
Mounted via shrink disc

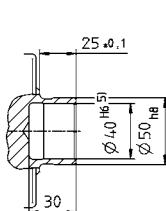

Non-tolerated dimensions ± 1 mm

- 1) Check motor shaft fit.
- 2) Min./Max. permissible motor shaft length.
Longer motor shafts are adaptable, please contact us.
- 3) The dimensions depend on the motor.
- 4) Smaller motor shaft diameter is compensated by a bushing with a minimum thickness of 1 mm.
- 5) Tolerance h6 for mounted shaft.

⚠ Motor mounting according to operating manual

SP*



SP+ 180 MC HIGH SPEED® 1-stage

			Standard version MC					Friction optimized version L						
Ratio ^{a)}	<i>i</i>		3	4	5	7	10	3	4	5	7	10		
Max. acceleration torque (max. 1000 cycles per hour)	T_{2B}	Nm	700	880	880	880	700	700	880	880	880	700		
		in.lb	6195	7788	7788	7788	6195							
cymex®-optimal nominal torque (please contact us regarding the design)	T_{2Ncym}	Nm	350	600	600	600	540	350	600	600	600	540		
		in.lb	3098	5310	5310	5310	4779							
Nominal output torque (with n_{1N})	T_{2N}	Nm	290	450	440	450	400	290	450	450	450	400		
		in.lb	2567	3983	3894	3983	3540							
Emergency stop torque (permitted 1000 times during the service life of the gearhead)	T_{2Not}	Nm	2200	2750	2750	2750	2200	2200	2750	2750	2750	2200		
		in.lb	19470	24338	24338	24338	19470							
Nominal input speed (with T_{2N} and 20°C ambient temperature) ^{b)}	n_{1N}	rpm	3000	3500	4500	4500	4500	3000	3500	4500	4500	4500		
cymex® optimized speed (please contact us regarding the design)	n_{1Ncym}	rpm	-	-	-	-	-	4000	4500	5000	5000	5000		
Max. input speed	n_{1Max}	rpm	4500	6000	6000	6000	6000	4500	6000	6000	6000	6000		
Mean no load running torque (with $n_1=3000$ rpm and 20°C gearhead temperature) ^{c)}	T_{012}	Nm	10.2	7.7	6.2	4.5	3.2	3.0	-	-	-	-		
		in.lb	90.3	68.1	54.9	39.8	28.3	26.6	-	-	-	-		
Max. torsional backlash	j_t	arcmin	Standard ≤ 4 / Reduced ≤ 2											
Torsional rigidity	C_{t21}	Nm/ arcmin	175											
		in.lb/ arcmin	1549											
Max. axial force ^{d)}	F_{2AMax}	N	14150					-						
		lb _f	3184					-						
Max. radial force ^{d)}	F_{2RMax}	N	15400					2000						
		lb _f	3465					450						
Max. tilting moment	M_{2KMax}	Nm	1600					208						
		in.lb	14160					1841						
Efficiency at full load	η	%	98.5					99						
Service life (For calculation, see the Chapter "Information")	L_h	h	> 30000											
Weight incl. standard adapter plate	m	kg	34											
		lb _m	75											
Operating noise (with $i=10$ and $n_1=3000$ rpm no load)	L_{PA}	dB(A)	≤ 66											
Max. permitted housing temperature		°C	+90											
		F	194											
Ambient temperature		°C	-15 to +40											
		F	5 to 104											
Lubrication	Lubricated for life													
Paint	Blue RAL 5002													
Direction of rotation	Motor and gearhead same direction													
Protection class	IP 65						IP 52							
Moment of inertia (relates to the drive)	M	48	J_1	kgcm ²	58.5	41.6	35.6	30.0	26.9	58.5	41.6	35.6	30.0	26.9
				10 ³ in.lb.s ²	51.8	36.8	31.5	26.6	23.8	51.8	36.8	31.5	26.6	23.8

Reduced mass moments of inertia available on request.

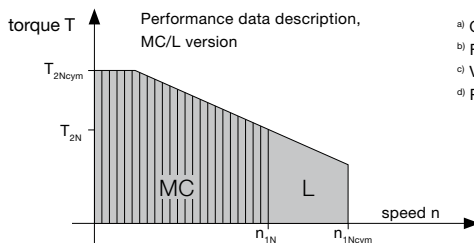

- ^{a)} Other ratios available on request
- ^{b)} For higher ambient temperatures, please reduce input speed
- ^{c)} Valid for clamping hub diameter of 48 mm
- ^{d)} Refers to center of the output shaft or flange

View A

View B

Motor shaft diameter [mm]

up to 48 ⁴⁾ (M)
clamping hub diameter

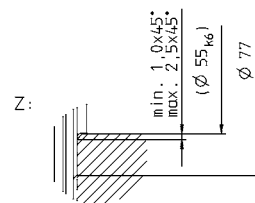
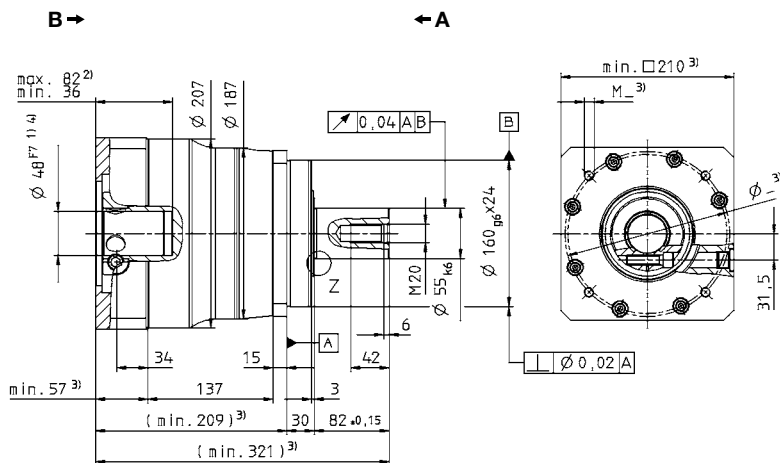
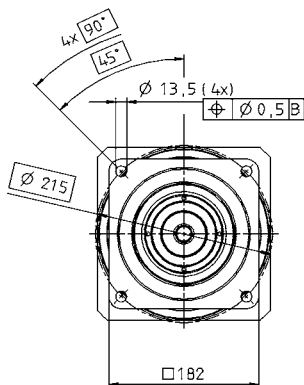

Alternatives: Output shaft variants

Keywayed output shaft in mm
E = key as per DIN 6885, sheet 1, form A

Involute gearing DIN 5480 in mm
X = W 55 x 2 x 30 x 26 x 6m, DIN 5480

Shaft mounted
Mounted via shrink disc

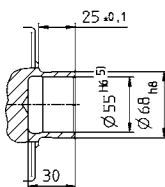
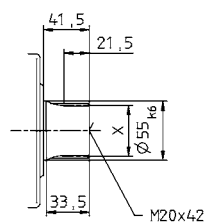
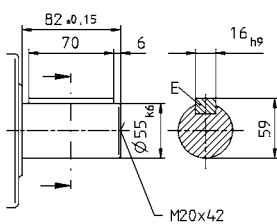

Non-tolerated dimensions ± 1 mm

- 1) Check motor shaft fit.
- 2) Min./Max. permissible motor shaft length.
Longer motor shafts are adaptable, please contact us.
- 3) The dimensions depend on the motor.
- 4) Smaller motor shaft diameter is compensated by a bushing with a minimum thickness of 1 mm.
- 5) Tolerance h6 for mounted shaft.

⚠ Motor mounting according to operating manual

SP



SP+ 180 MC HIGH SPEED® 2-stage

				2-stage									
Ratio ^{a)}	<i>i</i>			16	20	25	28	35	40	50	70	100	
Max. acceleration torque (max. 1000 cycles per hour)	T_{2B}	Nm	in.lb	880	880	880	880	880	880	880	880	700	
				7788	7788	7788	7788	7788	7788	7788	7788	7788	6195
cymex®-optimal nominal torque (please contact us regarding the design)	T_{2Ncym}	Nm	in.lb	-	-	-	-	-	-	-	-	-	
Nominal output torque (with n_{2N})	T_{2N}	Nm	in.lb	600	600	600	600	600	600	600	600	600	
				5310	5310	5310	5310	5310	5310	5310	5310	5310	5310
Emergency stop torque (permitted 1000 times during the service life of the gearhead)	T_{2Not}	Nm	in.lb	2750	2750	2750	2750	2750	2750	2750	2750	2200	
				24338	24338	24338	24338	24338	24338	24338	24338	24338	19470
Nominal input speed (with T_{2N} and 20°C ambient temperature) ^{b)}	n_{1N}	rpm		4500	4500	4500	4500	4500	4500	4500	4500	4500	
Max. input speed	n_{1Max}	rpm		6000	6000	6000	6000	6000	6000	6000	6000	6000	
Mean no load running torque (with $n_1=3000$ rpm and 20°C gearhead temperature) ^{c)}	T_{012}	Nm	in.lb	3.2	2.6	2.3	1.9	1.7	1.4	1.2	1.0	0.9	
				28.3	23.0	20.4	16.8	15.0	12.4	10.6	8.9	8.0	
Max. torsional backlash	j_t	arcmin		Standard ≤ 6 / Reduced ≤ 4									
Torsional rigidity	C_{I21}	Nm/ arcmin	in.lb/ arcmin	175									
				149									
Max. axial force ^{d)}	F_{2AMax}	N	lb _f	14150									
				3184									
Max. radial force ^{d)}	F_{2RMMax}	N	lb _f	15400									
				3465									
Max. tilting moment	M_{2KMax}	Nm	in.lb	1600									
				14160									
Efficiency at full load	η	%		96.5									
Service life (For calculation, see the Chapter "Information")	L_h	h		> 30000									
Weight incl. standard adapter plate	<i>m</i>	kg	lb _m	36									
				80									
Operating noise (with $i=100$ and $n_1=3000$ rpm no load)	L_{PA}	dB(A)		≤ 66									
Max. permitted housing temperature		°C	F	+90									
				194									
Ambient temperature		°C	F	-15 to +40									
				5 to 104									
Lubrication				Lubricated for life									
Paint				Blue RAL 5002									
Direction of rotation				Motor and gearhead same direction									
Protection class				IP 65									
Moment of inertia (relates to the drive)	K	38	J_i	kgcm ²	13.5	12.0	11.7	10.6	10.4	9.74	9.68	9.63	9.60
				10 ⁻³ in.lb.s ²	12.0	10.6	10.4	9.34	9.23	8.62	8.57	8.52	8.49

Reduced mass moments of inertia available on request.

^{a)} Other ratios available on request

^{b)} For higher ambient temperatures, please reduce input speed

^{c)} Valid for clamping hub diameter of 38 mm

^{d)} Refers to center of the output shaft or flange

View A

View B

Motor shaft diameter [mm]

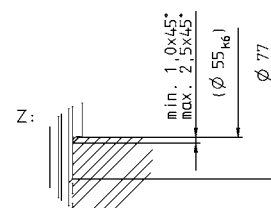
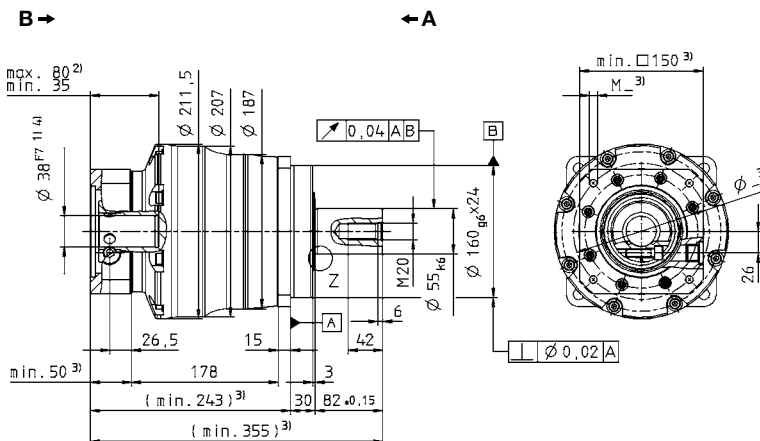
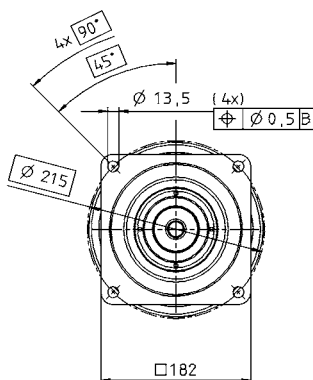
up to 38⁴⁾ (K)
clamping hub diameter

Alternatives: Output shaft variants

Keywayed output shaft in mm
E = key as per DIN 6885, sheet 1, form A

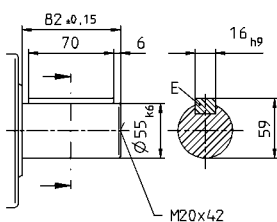

Involute gearing DIN 5480 in mm
X = W 55 x 2 x 30 x 26 x 6m, DIN 5480

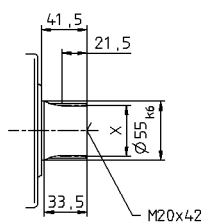

Shaft mounted
Mounted via shrink disc

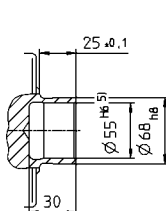

Non-tolerated dimensions ± 1 mm

- 1) Check motor shaft fit.
- 2) Min./Max. permissible motor shaft length.
Longer motor shafts are adaptable, please contact us.
- 3) The dimensions depend on the motor.
- 4) Smaller motor shaft diameter is compensated by a bushing with a minimum thickness of 1 mm.
- 5) Tolerance h6 for mounted shaft.

⚠ Motor mounting according to operating manual

SP



SP+ 210 MC HIGH SPEED® 1/2-stage

				1-stage					2-stage									
Ratio ^{a)}		<i>i</i>		3	4	5	7	10	16	20	25	28	35	40	50	70	100	
Max. acceleration torque (max. 1000 cycles per hour)	T_{2B}	Nm		1200	2000	2000	1700	1200	1680	1800	2000	1680	1920	1040	1300	1700	1200	
		in.lb		10620	17700	17700	15045	10620	14868	15930	17700	14868	16992	9204	11505	15045	10620	
cymex®-optimal nominal torque (please contact us regarding the design)	T_{2Ncym}	Nm		- Please contact us -														
		in.lb																
Nominal output torque (with n_{2N})	T_{2N}	Nm		900	1300	1150	1000	800	840	780	975	780	975	800	1000	1000	800	
		in.lb		7965	11505	10178	8850	7080	7434	6903	8629	6903	8629	7080	8850	8850	7080	
Emergency stop torque (permitted 1000 times during the service life of the gearhead)	T_{2Nst}	Nm		5000	5200	5200	5200	5000	5200	5200	5200	5200	5200	5200	5200	5200	5000	
		in.lb		44250	46020	46020	46020	44250	46020	46020	46020	46020	46020	46020	46020	46020	44250	
Nominal input speed (with T_{2N} and 20°C ambient temperature) ^{b)}	n_{1N}	rpm		2250	2500	3500	3500	3500	3500	4500	4500	4500	4500	4500	4500	4500	4500	
Max. input speed	n_{1Max}	rpm		3400	6000	6000	6000	6000	6000	6000	6000	6000	6000	6000	6000	6000	6000	
Mean no load running torque (with $n_1=2000$ rpm and 20°C gearhead temperature)	T_{012}	Nm		13.0	9.0	6.5	4.0	2.5	3.0	2,5	2,5	2,0	2,0	1,5	1,5	1,5	1,5	
		in.lb		115.1	79.7	57.5	35.4	22.1	27	22	22	18	18	13	13	13	13	
Max. torsional backlash	j_t	arcmin		Standard ≤ 4 / Reduced ≤ 2					Standard ≤ 5 / Reduced ≤ 4									
Torsional rigidity	C_{I2I}	Nm/arcmin		400					400									
		in.lb/arcmin		3540					3540									
Max. axial force ^{c)}	F_{2AMax}	N		30000					30000									
		lb _f		6750					6750									
Max. radial force ^{c)}	F_{2RMax}	N		21000					21000									
		lb _f		4725					4725									
Max. tilting moment	M_{2KMMax}	Nm		3100					3100									
		in.lb		27435					27435									
Efficiency at full load	η	%		98.5					96.5									
Service life (For calculation, see the Chapter "Information")	L_h	h		> 30000					> 30000									
Weight incl. standard adapter plate	m	kg		56					53									
		lb _m		124					117									
Operating noise (with $i=10$ and $n_1=2000$ rpm no load)	L_{PA}	dB(A)		≤ 64														
Max. permitted housing temperature		°C		+90														
		F		194														
Ambient temperature		°C		-15 to +40														
		F		32 to 194														
Lubrication				Lubricated for life														
Paint				Blue RAL 5002														
Direction of rotation				Motor and gearhead same direction														
Protection class				IP 65														
Moment of inertia (relates to the drive)	M	48	J_1	kgcm ²	-	-	-	-	-	34.5	31.5	30.8	30.0	29.7	28.5	28.3	28.1	28.0
				10 ⁻³ in.lb.s ²														
Clamping hub diameter (mm)	N	55	J_1	kgcm ²	139.0	94.3	76.9	61.5	53.1	-	-	-	-	-	-	-	-	-
				10 ⁻³ in.lb.s ²	123.0	83.5	68.1	54.4	47.0									

Reduced mass moments of inertia available on request.

^{a)} Other ratios available on request

^{b)} For higher ambient temperatures, please reduce input speed

^{c)} Refers to center of the output shaft or flange

Motor shaft diameter [mm]

1-stage:

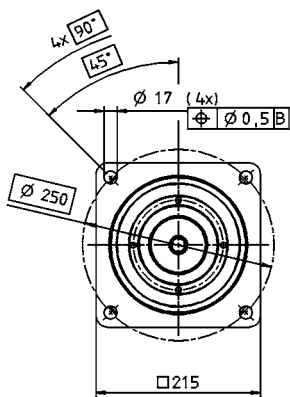

up to 55⁴⁾ (N)
clamping hub
diameter

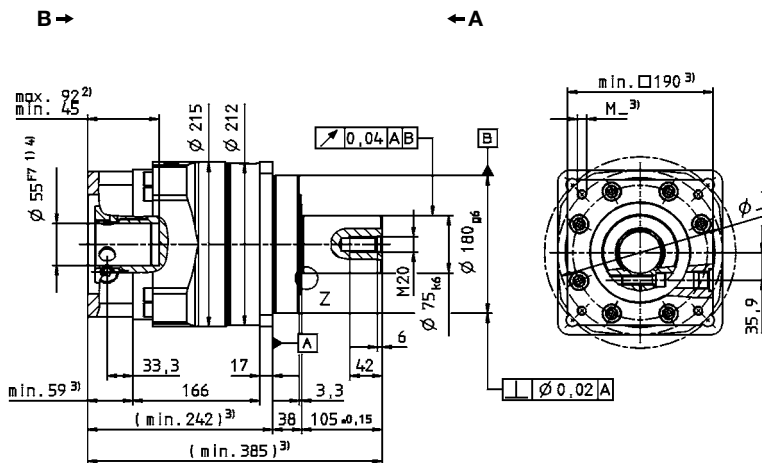

2-stage:

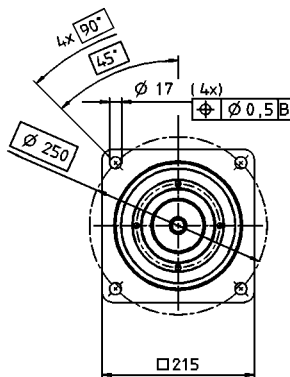

up to 48⁴⁾ (M)
clamping hub
diameter

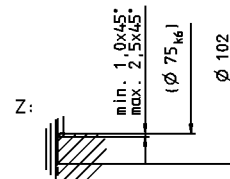
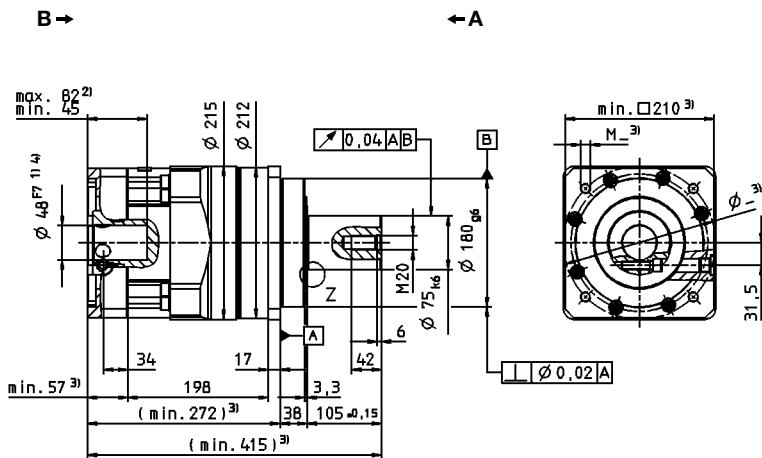

Alternatives: Output shaft variants

Keywayed output shaft in mm
E = key as per DIN 6885, sheet 1, form A

Involute gearing DIN 5480 in mm
X = W 70 x 2 x 30 x 34 x 6m, DIN 5480

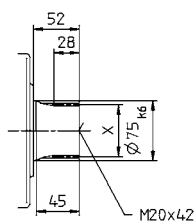
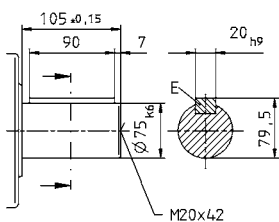

Non-tolerated dimensions ± 1.5 mm

- 1) Check motor shaft fit.
- 2) Min./Max. permissible motor shaft length.
Longer motor shafts are adaptable, please contact us.
- 3) The dimensions depend on the motor.
- 4) Smaller motor shaft diameter is compensated by a bushing with a minimum thickness of 1 mm.

⚠ Motor mounting according to operating manual

SP:



SP+ 240 MC HIGH SPEED® 1/2-stage

				1-stage					2-stage									
Ratio ^{a)}		<i>i</i>		3	4	5	7	10	16	20	25	28	35	40	50	70	100	
Max. acceleration torque (max. 1000 cycles per hour)	T_{2B}	Nm		1750	3500	3600	2700	1800	3500	3500	3600	2900	3600	1680	2100	2700	1800	
		in.lb		15488	30975	31860	23895	15930	30975	30975	31860	25665	31860	14868	18585	23895	15930	
cymex®-optimal nominal torque (please contact us regarding the design)	T_{2Ncym}	Nm		- Please contact us -														
		in.lb		- Please contact us -														
Nominal output torque (with n_n)	T_{2N}	Nm		1400	1960	1770	1500	1100	1790	1770	1730	1840	1930	1300	1625	1500	1100	
		in.lb		12390	17346	15665	13275	9735	15842	15665	15311	16284	17081	11505	14381	13275	9735	
Emergency stop torque (permitted 1000 times during the service life of the gearhead)	T_{2Not}	Nm		6800	8500	8500	8500	6800	8500	8500	8500	8500	8500	8500	8500	8500	6800	
		in.lb		60180	75225	75225	75225	60180	75225	75225	75225	75225	75225	75225	75225	75225	60180	
Nominal input speed (with T_{2N} and 20°C ambient temperature) ^{b)}	n_{1N}	rpm		1750	2250	3000	3000	3000	3500	4500	4500	4500	4500	4500	4500	4500	4500	
Max. input speed	n_{1Max}	rpm		3400	4000	5000	5000	5000	6000	6000	6000	6000	6000	6000	6000	6000	6000	
Mean no load running torque (with $n_n=2000$ rpm and 20°C gearhead temperature)	T_{012}	Nm		24	18	13	7,0	5,0	5,0	4,5	4,0	3,5	3,0	2,5	2,5	2,5	2,0	
		in.lb		212	159	115	62	44	44	40	35	31	27	22	22	22	18	
Max. torsional backlash	j_t	arcmin		Standard ≤ 4 / Reduced ≤ 2					Standard ≤ 5 / Reduced ≤ 4									
Torsional rigidity	C_{I21}	Nm/arcmin		550					550									
		in.lb/arcmin		4868					4868									
Max. axial force ^{c)}	F_{2AMax}	N		33000					33000									
		lb _f		7425					7425									
Max. radial force ^{c)}	F_{2RMax}	N		30000					30000									
		lb _f		6750					6750									
Max. tilting moment	M_{2KMMax}	Nm		5000					5000									
		in.lb		44250					44250									
Efficiency at full load	η	%		98.5					96.5									
Service life (For calculation, see the Chapter "Information")	L_h	h		> 30000					> 30000									
Weight incl. standard adapter plate	m	kg		77					76									
		lb _m		170					168									
Operating noise (with $i=10$ and $n_n=3000$ rpm no load)	L_{PA}	dB(A)		≤ 66														
Max. permitted housing temperature		°C		+90														
		F		194														
Ambient temperature		°C		-15 to +40														
		F		5 to 104														
Lubrication				Lubricated for life														
Paint				Blue RAL 5002														
Direction of rotation				Motor and gearhead same direction														
Protection class				IP 65														
Moment of inertia (relates to the drive)	M	48	J_1	kgcm ²	-	-	-	-	-	39.2	34.6	33.2	30.5	29.7	28.2	27.9	27.6	27.5
				10 ³ in.lb.s ²	-	-	-	-	-	34.7	30.6	29.4	27.0	26.3	25.0	24.7	24.4	24.3
Clamping hub diameter [mm]	O	60	J_1	kgcm ²	260.2	198.2	163.0	84.4	70.8	-	-	-	-	-	-	-	-	-
				10 ³ in.lb.s ²	230.3	175.4	144.3	74.7	62.7	-	-	-	-	-	-	-	-	-

Reduced mass moments of inertia available on request.

^{a)} Other ratios available on request

^{b)} For higher ambient temperatures, please reduce input speed

^{c)} Refers to center of the output shaft or flange

Motor shaft diameter [mm]

1-stage:

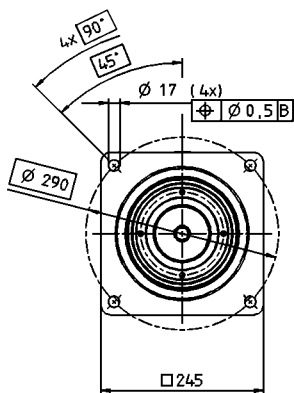

up to 60⁴⁾ (O)
clamping hub diameter

B →

← A

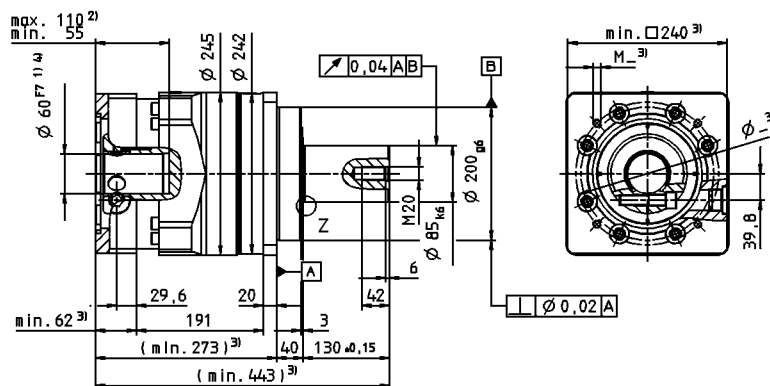

2-stage:

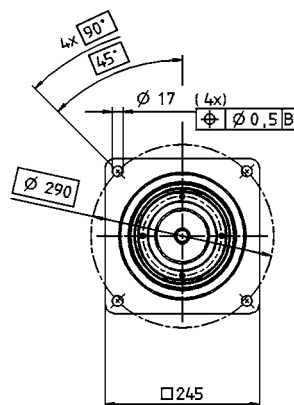

up to 48⁴⁾ (M)
clamping hub diameter

B →

← A

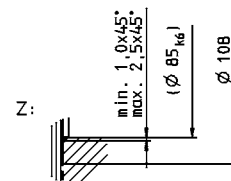
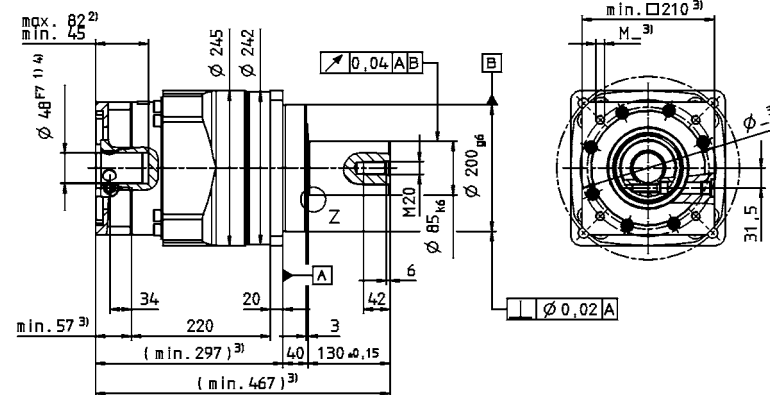

Alternatives: Output shaft variants

Keywayed output shaft in mm
E = key as per DIN 6885, sheet 1, form A

Involute gearing DIN 5480 in mm
X = W 80 x 2 x 30 x 38 x 6m, DIN 5480

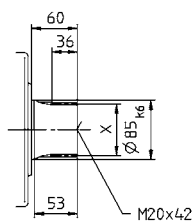
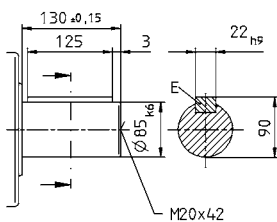

Non-tolerated dimensions ± 1.5 mm

- 1) Check motor shaft fit.
- 2) Min./Max. permissible motor shaft length.
Longer motor shafts are adaptable, please contact us.
- 3) The dimensions depend on the motor.
- 4) Smaller motor shaft diameter is compensated by a bushing with a minimum thickness of 1 mm.

⚠ Motor mounting according to operating manual

SP:



LP+/LPB+ – Economical precision

A reliable and durable player among planetary gearheads



LP+/LPB+

Specifications \ Version	LP+/LPB+		
	+	++	+++
Positioning accuracy	[Progressive bar chart]		
Rigidity	[Progressive bar chart]		
Smooth-running	[Progressive bar chart]		
Speed capacity	[Progressive bar chart]		
Power density	[Progressive bar chart]		
Max. axial/radial forces	[Progressive bar chart]		



NEMA flange



Belt pulley (PLPB)



Output flange (LPB+)



Couplings



Shrink disc



Rack / Pinion

Options

Smooth output shaft
Output flange (LPB+)
Food-grade grease 

Accessories

Rack / Pinion (see page 310)
Belt pulley (PLPB)
Couplings (see page 342)
Shrink disc (see page 342)
NEMA flange

LP+ 050 1/2-stage

Ratio		<i>i</i>	1-stage				2-stage						
			4	5	7	10	16	20	25	35	50	70	100
Max. acceleration torque (max. 1000 cycles per hour)	T_{2B}	Nm	11	12	12	11	11	11	12	12	12	12	11
		in.lb	100	110	110	100	100	100	110	110	110	110	100
Nominal output torque (with n_{1N})	T_{2N}	Nm	5.2	5.7	5.7	5.2	5.2	5.2	5.7	5.7	5.7	5.7	5.2
		in.lb	46	50	50	46	46	46	50	50	50	50	46
Emergency stop torque (permitted 1000 times during the service life of the gearhead)	T_{2Not}	Nm	26	26	26	26	26	26	26	26	26	26	26
		in.lb	230	230	230	230	230	230	230	230	230	230	230
Nominal input speed (with T_{2N} and 20°C ambient temperature ^{a)})	n_{1N}	rpm	4000	4000	4000	4000	4000	4000	4000	4000	4000	4000	
Max. input speed	n_{1Max}	rpm	8000	8000	8000	8000	8000	8000	8000	8000	8000	8000	
Mean no load running torque (with $n_1=3000$ rpm and 20°C gearhead temperature)	T_{012}	Nm	0.05	0.05	0.05	0.05	0.05	0.05	0.05	0.05	0.05	0.05	
		in.lb	0.4	0.4	0.4	0.4	0.4	0.4	0.4	0.4	0.4	0.4	
Max. torsional backlash	j_t	arcmin	Standard ≤ 12 / Reduced ≤ 10				Standard ≤ 15 / Reduced ≤ 13						
Torsional rigidity	C_{t21}	Nm/arcmin	1.2	1.2	1.2	0.9	1.2	1.2	1.2	1.2	1.2	1.2	0.9
		in.lb/arcmin	11	11	11	8	11	11	11	11	11	11	8
Max. axial force ^{b)}	F_{2AMax}	N	700				700						
		lb _f	160				160						
Max. radial force ^{b)}	F_{2RMax}	N	650				650						
		lb _f	150				150						
Efficiency at full load	η	%	97				95						
Service life (For calculation, see the Chapter "Information")	L_n	h	> 20000				> 20000						
Weight incl. standard adapter plate	m	kg	0.75				0.95						
		lb _m	1.7				2.1						
Operating noise (with $n_1=3000$ rpm no load)	L_{PA}	dB(A)	≤ 68										
Max. permitted housing temperature		°C	+90										
		F	194										
Ambient temperature		°C	-15 to +40										
		F	5 to 104										
Lubrication			Lubricated for life										
Paint			Blue RAL 5002										
Direction of rotation			Motor and gearhead same direction										
Protection class			IP 64										
Moment of inertia (relates to the drive)	11	J_1	kgcm ²	0.05	0.05	0.05	0.05	0.05	0.05	0.05	0.05	0.05	0.05
			10 ⁻² in.lb.in ²	0.05	0.04	0.04	0.04	0.05	0.04	0.04	0.04	0.04	0.04
Clamping hub diameter (mm)	14	J_1	kgcm ²	0.2	0.2	0.2	0.2	0.2	0.2	0.2	0.2	0.2	0.2
			10 ⁻² in.lb.in ²	0.2	0.2	0.2	0.2	0.2	0.2	0.2	0.2	0.2	0.2

^{a)} For higher ambient temperatures, please reduce input speed

^{b)} Refers to center of the output shaft, if $n_2 = 100$ rpm

LP+ 1-stage:

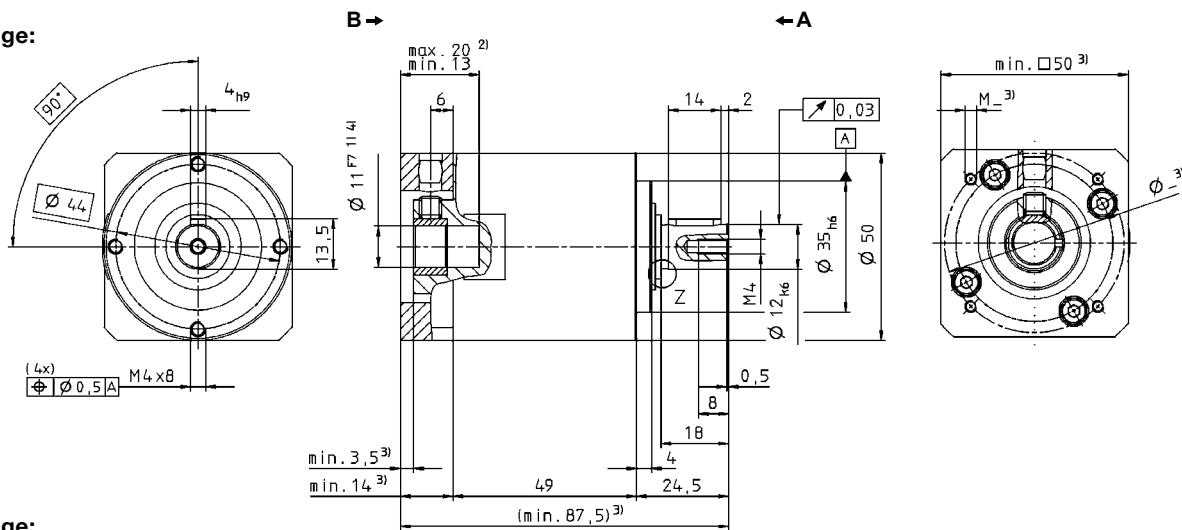

LP+ 2-stage:

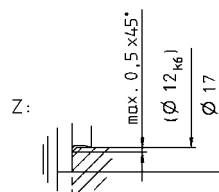
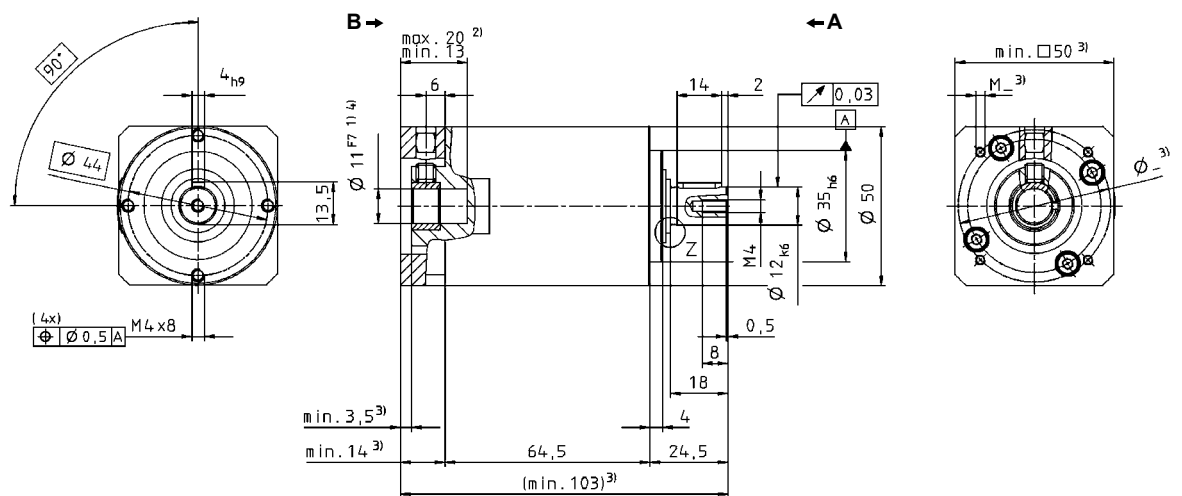

Non-tolerated dimensions ± 1 mm

- 1) Check motor shaft fit.
- 2) Min./Max. permissible motor shaft length. Longer motor shafts are adaptable, please contact us.
- 3) The dimensions depend on the motor.
- 4) Smaller motor shaft diameter is compensated by a bushing. Motor shaft diameters up to 14mm available – please contact WITTENSTEIN alpha

Motor mounting according to operating manual



LP+ 070 1/2-stage

		1-stage					2-stage										
Ratio	<i>i</i>	3	4	5	7	10	15	16	20	25	30	35	50	70	100		
Max. acceleration torque (max. 1000 cycles per hour)	T_{2B}	Nm	32	35	35	35	32	32	35	35	35	35	32	35	35	32	
		in.lb	280	310	310	310	280	280	310	310	310	280	310	310	310	280	
Nominal output torque (with n_{1N})	T_{2N}	Nm	16.5	18	18	18	16.5	16.5	18	18	18	16.5	18	18	16.5		
		in.lb	150	160	160	160	150	150	160	160	160	150	160	160	150		
Emergency stop torque (permitted 1000 times during the service life of the gearhead)	T_{2Not}	Nm	65	75	75	75	75	75	75	75	75	75	75	75	75		
		in.lb	580	660	660	660	660	660	660	660	660	660	660	660	660		
Nominal input speed (with T_{2N} and 20°C ambient temperature ^{a)})	n_{1N}	rpm	3700	3700	3700	3700	3700	3700	3700	3700	3700	3700	3700	3700	3700		
Max. input speed	n_{1Max}	rpm	6000	6000	6000	6000	6000	6000	6000	6000	6000	6000	6000	6000	6000		
Mean no load running torque (with $n_1=3000$ rpm and 20°C gearhead temperature)	T_{012}	Nm	0.3	0.3	0.2	0.1	0.1	0.1	0.1	0.1	0.1	0.1	0.1	0.1	0.1		
		in.lb	2.7	2.2	1.8	1.2	1.2	1.2	1.2	1.2	1.2	1.2	1.2	1.2	0.9		
Max. torsional backlash	j_t	arcmin	Standard ≤ 12 / Reduced ≤ 8					Standard ≤ 15 / Reduced ≤ 10									
Torsional rigidity	C_{t21}	Nm/ arcmin	2.8	3.3	3.3	3.3	2.8	2.8	3.3	3.3	3.3	3.3	2.8	3.3	3.3	3.3	
		in.lb/ arcmin	25	29	29	29	25	25	29	29	29	29	25	29	29	29	
Max. axial force ^{b)}	F_{2AMax}	N	1550					1550									
		lb _f	349					349									
Max. radial force ^{b)}	F_{2RMax}	N	1450					1450									
		lb _f	326					326									
Efficiency at full load	η	%	97					95									
Service life (For calculation, see the Chapter "Information")	L_n	h	> 20000					> 20000									
Weight incl. standard adapter plate	m	kg	2.0					2.4									
		lb _m	4.4					5.3									
Operating noise (with $n_1=3000$ rpm no load)	L_{PA}	dB(A)	≤ 70														
Max. permitted housing temperature		°C	+90														
		F	194														
Ambient temperature		°C	-15 to +40														
		F	5 to 104														
Lubrication			Lubricated for life														
Paint			Blue RAL 5002														
Direction of rotation			Motor and gearhead same direction														
Protection class			IP 64														
Moment of inertia (relates to the drive)	16	J_1	kgcm ²	0.3	0.3	0.2	0.2	0.2	0.2	0.2	0.2	0.2	0.2	0.2	0.2		
			10 ⁻³ in.lb.in ²	0.3	0.2	0.2	0.2	0.2	0.2	0.2	0.2	0.2	0.2	0.2	0.2		
Clamping hub diameter (mm)	19	J_1	kgcm ²	0.6	0.5	0.5	0.5	0.5	0.5	0.5	0.5	0.5	0.5	0.5			
			10 ⁻³ in.lb.in ²	0.5	0.5	0.5	0.4	0.4	0.5	0.5	0.5	0.5	0.4	0.5			

^{a)} For higher ambient temperatures, please reduce input speed

^{b)} Refers to center of the output shaft, if $n_2 = 100$ rpm

LP+ 1-stage:

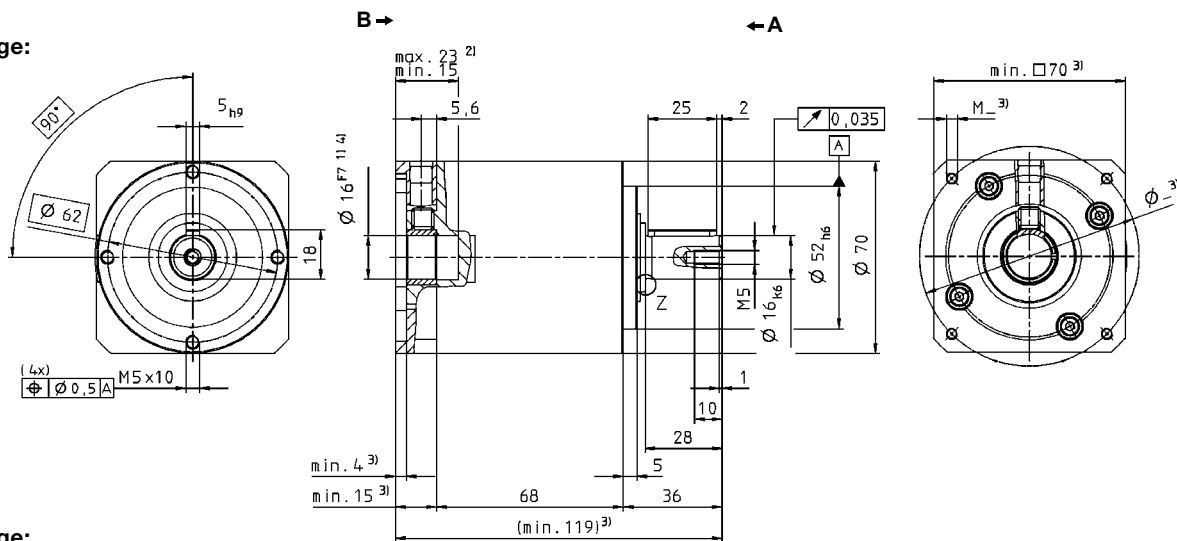

LP+ 2-stage:

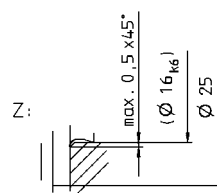
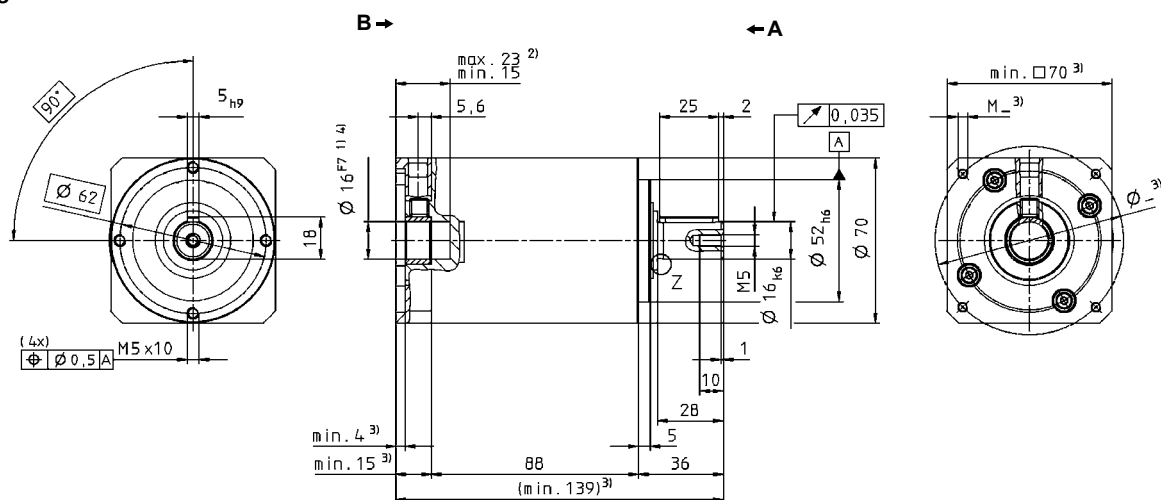

Non-tolerated dimensions $\pm 1\text{mm}$

- 1) Check motor shaft fit.
- 2) Min./Max. permissible motor shaft length. Longer motor shafts are adaptable, please contact us.
- 3) The dimensions depend on the motor.
- 4) Smaller motor shaft diameter is compensated by a bushing. Motor shaft diameters up to 19mm available – please contact WITTENSTEIN alpha



LPB+ 070 1 stage

			1-stage				
Ratio	<i>i</i>		3	4	5	7	10
Max. acceleration torque (max. 1000 cycles per hour)	T_{2B}	Nm	32	35	35	35	32
		in.lb	280	310	310	310	280
Nominal output torque (with n_{1N})	T_{2N}	Nm	16.5	18	18	18	16.5
		in.lb	150	160	160	160	150
Emergency stop torque (permitted 1000 times during the service life of the gearhead)	T_{2Not}	Nm	65	75	75	75	75
		in.lb	580	660	660	660	660
Nominal input speed (with T_{2N} and 20°C ambient temperature ^{a)})	n_{1N}	rpm	3700	3700	3700	3700	3700
Max. input speed	n_{1Max}	rpm	6000	6000	6000	6000	6000
Mean no load running torque (with $n_1=3000$ rpm and 20°C gearhead temperature)	T_{012}	Nm	0.3	0.3	0.2	0.1	0.1
		in.lb	2.7	2.2	1.8	1.2	1.2
Max. torsional backlash	j_t	arcmin	Standard ≤ 12 / Reduced ≤ 8				
Torsional rigidity	C_{t21}	Nm/ arcmin	-	-	-	-	-
		in.lb/ arcmin	-	-	-	-	-
Max. axial force ^{b)}	F_{2AMax}	N	1550				
		lb _f	349				
Max. radial force ^{c)}	F_{2RMax}	N	3000				
		lb _f	675				
Efficiency at full load	η	%	97				
Service life (For calculation, see the Chapter "Information")	L_n	h	> 20000				
Weight incl. standard adapter plate	m	kg	1.6				
		lb _m	3.5				
Operating noise (with $n_1=3000$ rpm no load)	L_{PA}	dB(A)	≤ 70				
Max. permitted housing temperature		°C	+90				
		F	194				
Ambient temperature		°C	-15 to +40				
		F	5 to 104				
Lubrication			Lubricated for life				
Paint			Blue RAL 5002				
Direction of rotation			Motor and gearhead same direction				
Protection class			IP 64				
Moment of inertia (relates to the drive)	J_i	kgcm ²	0.3	0.3	0.2	0.2	0.2
		10 ⁻³ in.lb.s ²	0.3	0.2	0.2	0.2	0.2
Clamping hub diameter (mm)	J_i	kgcm ²	0.6	0.5	0.5	0.5	0.5
		10 ⁻³ in.lb.s ²	0.5	0.5	0.5	0.4	0.4

^{a)} For higher ambient temperatures, please reduce input speed

^{b)} Refers to center of the output shaft, if $n_2 = 100$ rpm

^{c)} With mounted PLPB+ belt pulley and 100 rpm

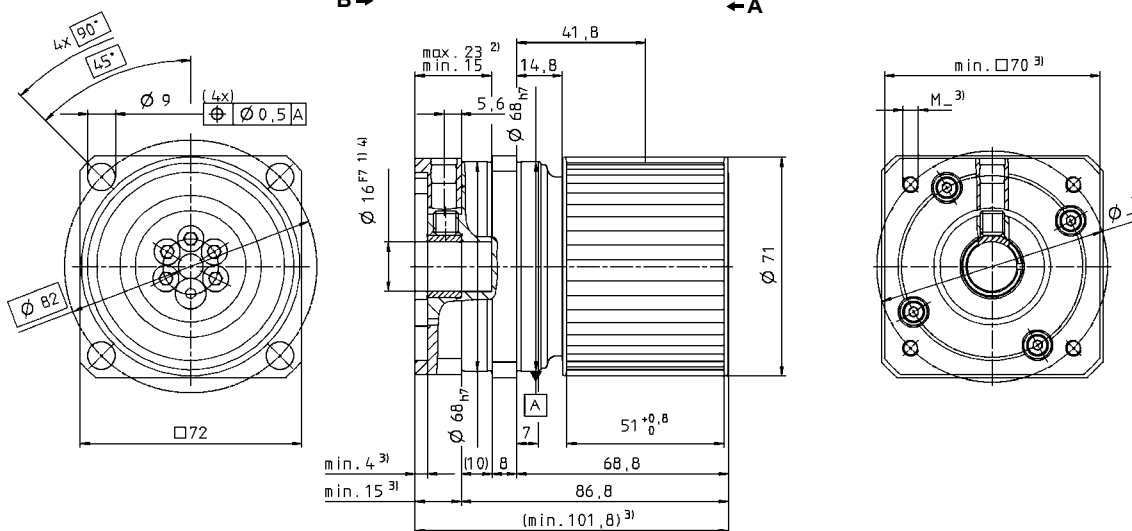
LPB⁺ 1-stage:

Supplement: Belt pulley PLPB⁺ (not in the scope of delivery)

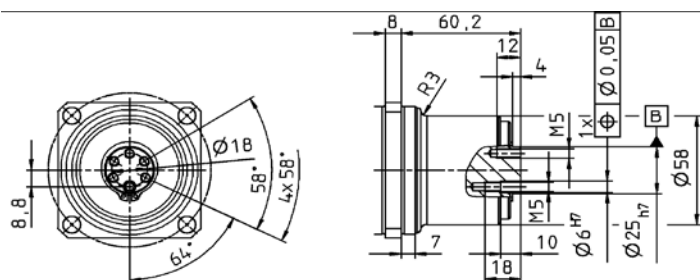

Belt Pulley PLPB+ 070 Profile AT5-0			
Pitch	p	mm	5
Number of teeth	z		43
Circumference	$z * p$	mm/rotation	215
Inertia	J	kgcm ²	3.86
Mass	m	kg	0.48

Non-tolerated dimensions ± 1 mm

- 1) Check motor shaft fit.
- 2) Min./Max. permissible motor shaft length. Longer motor shafts are adaptable, please contact us.
- 3) The dimensions depend on the motor.
- 4) Smaller motor shaft diameter is compensated by a bushing. Motor shaft diameters up to 19mm available – please contact WITTENSTEIN alpha

Motor mounting according to operating manual

LP+ 090 1/2-stage

		1-stage					2-stage										
Ratio	<i>i</i>	3	4	5	7	10	15	16	20	25	30	35	50	70	100		
Max. acceleration torque (max. 1000 cycles per hour)	T_{2B}	Nm	80	90	90	90	80	80	90	90	90	90	80	90	90	80	
		in.lb	710	800	800	800	710	710	800	800	800	800	710	800	800	800	710
Nominal output torque (with n_{1N})	T_{2N}	Nm	40	45	45	45	40	40	45	45	45	40	45	45	45	40	
		in.lb	350	400	400	400	350	350	400	400	400	400	350	400	400	400	350
Emergency stop torque (permitted 1000 times during the service life of the gearhead)	T_{2Not}	Nm	185	190	190	190	190	190	190	190	190	190	190	190	190	190	
		in.lb	1640	1680	1680	1680	1680	1680	1680	1680	1680	1680	1680	1680	1680	1680	1680
Nominal input speed (with T_{2N} and 20°C ambient temperature ^{a)})	n_{1N}	rpm	3400	3400	3400	3400	3400	3400	3400	3400	3400	3400	3400	3400	3400	3400	
Max. input speed	n_{1Max}	rpm	6000	6000	6000	6000	6000	6000	6000	6000	6000	6000	6000	6000	6000	6000	
Mean no load running torque (with $n_1=3000$ rpm and 20°C gearhead temperature)	T_{012}	Nm	0.6	0.6	0.5	0.4	0.4	0.3	0.3	0.3	0.3	0.3	0.3	0.3	0.3	0.3	
		in.lb	5.3	4.9	4.4	3.5	3.4	2.7	2.7	2.7	2.7	2.7	2.7	2.7	2.2	2.2	2.2
Max. torsional backlash	j_t	arcmin	Standard ≤ 12 / Reduced ≤ 8					Standard ≤ 15 / Reduced ≤ 10									
Torsional rigidity	C_{t21}	Nm/ arcmin	8.5	9.5	9.5	9.5	8.5	8.5	9.5	9.5	9.5	9.5	8.5	9.5	9.5	9.5	8.5
		in.lb/ arcmin	75	84	84	84	75	75	84	84	84	84	75	84	84	84	75
Max. axial force ^{b)}	F_{2AMax}	N	1900					1900									
		lb _f	428					428									
Max. radial force ^{b)}	F_{2RMax}	N	2400					2400									
		lb _f	540					540									
Efficiency at full load	η	%	97					95									
Service life (For calculation, see the Chapter "Information")	L_n	h	> 20000					> 20000									
Weight incl. standard adapter plate	m	kg	4.0					5.0									
		lb _m	8.8					11.1									
Operating noise (with $n_1=3000$ rpm no load)	L_{PA}	dB(A)	≤ 72														
Max. permitted housing temperature		°C	+90														
		F	194														
Ambient temperature		°C	-15 to +40														
		F	5 to 104														
Lubrication			Lubricated for life														
Paint			Blue RAL 5002														
Direction of rotation			Motor and gearhead same direction														
Protection class			IP 64														
Moment of inertia (relates to the drive)	24	J_1	kgcm ²	1.8	1.6	1.6	1.5	1.4	1.5	1.6	1.6	1.5	1.4	1.5	1.4	1.4	1.4
			10 ⁻³ in.lb.in ²	1.6	1.4	1.4	1.3	1.3	1.3	1.4	1.4	1.3	1.3	1.3	1.3	1.3	1.3
Clamping hub diameter (mm)	28	J_1	kgcm ²	2.1	1.9	1.9	1.8	1.7	1.8	1.9	1.9	1.8	1.7	1.8	1.7	1.7	1.7
			10 ⁻³ in.lb.in ²	1.9	1.7	1.6	1.6	1.5	1.6	1.6	1.6	1.6	1.5	1.6	1.5	1.5	1.5

^{a)} For higher ambient temperatures, please reduce input speed

^{b)} Refers to center of the output shaft, if $n_2 = 100$ rpm

LP+ 1-stage:

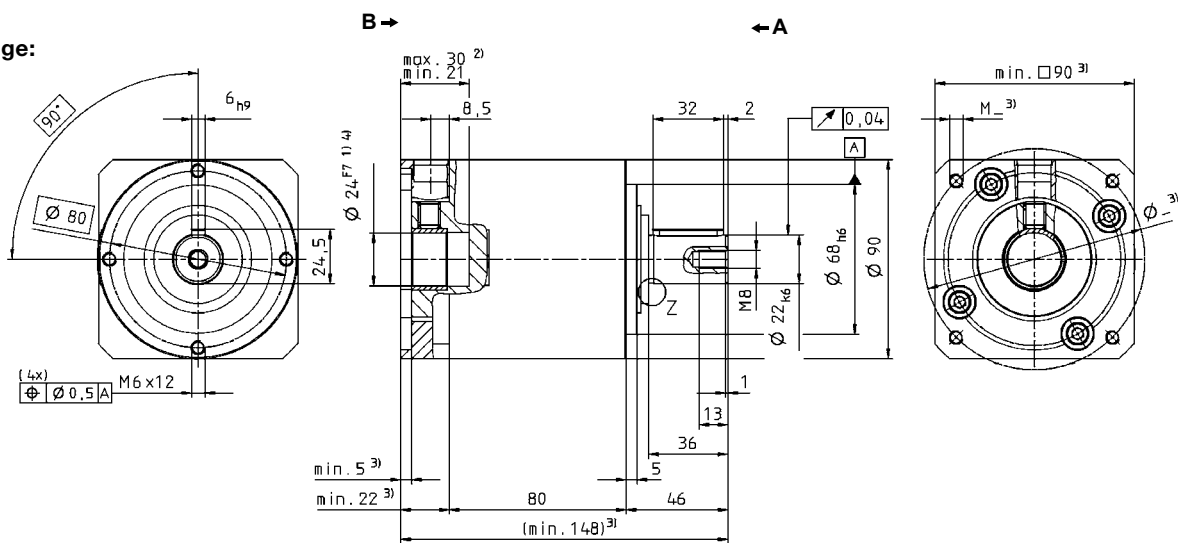

LP+ 2-stage:

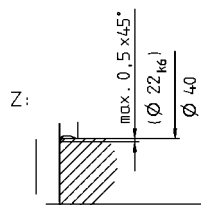
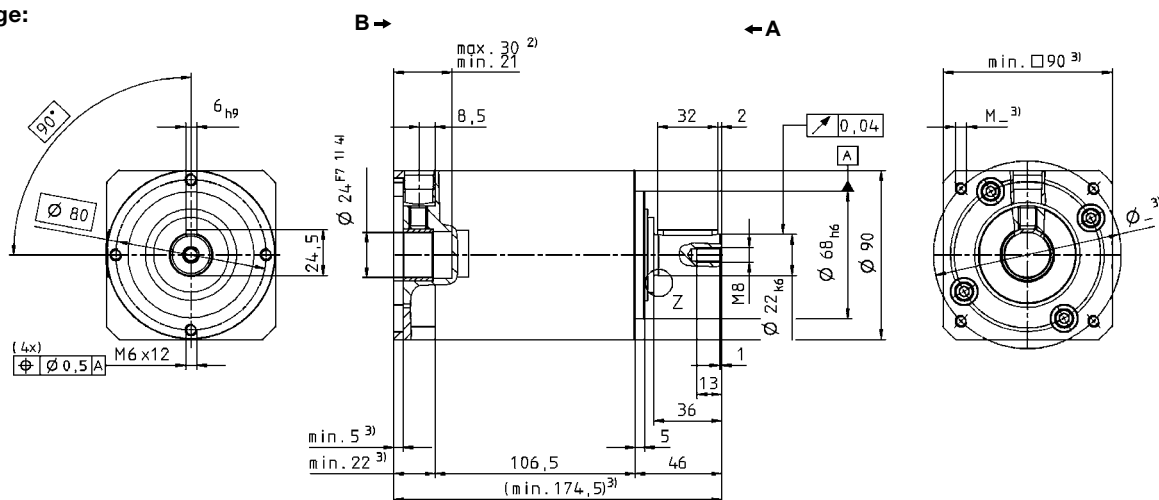

Non-tolerated dimensions $\pm 1\text{mm}$

- 1) Check motor shaft fit.
- 2) Min./Max. permissible motor shaft length. Longer motor shafts are adaptable, please contact us.
- 3) The dimensions depend on the motor.
- 4) Smaller motor shaft diameter is compensated by a bushing. Motor shaft diameters up to 28mm available – please contact WITTENSTEIN alpha

Motor mounting according to operating manual



LPB+ 090 1-stage

		1-stage						
Ratio	<i>i</i>		3	4	5	7	10	
Max. acceleration torque (max. 1000 cycles per hour)	T_{2B}	Nm	80	90	90	90	80	
		in.lb	710	800	800	800	710	
Nominal output torque (with n_{1N})	T_{2N}	Nm	40	45	45	45	40	
		in.lb	350	400	400	400	350	
Emergency stop torque (permitted 1000 times during the service life of the gearhead)	T_{2Not}	Nm	185	190	190	190	190	
		in.lb	1640	1680	1680	1680	1680	
Nominal input speed (with T_{2N} and 20°C ambient temperature ^{a)})	n_{1N}	rpm	3400	3400	3400	3400	3400	
Max. input speed	n_{1Max}	rpm	6000	6000	6000	6000	6000	
Mean no load running torque (with $n_1=3000$ rpm and 20°C gearhead temperature)	T_{012}	Nm	0.6	0.6	0.5	0.4	0.4	
		in.lb	5.3	4.9	4.4	3.5	3.4	
Max. torsional backlash	j_t	arcmin	Standard ≤ 12 / Reduced ≤ 8					
Torsional rigidity	C_{t21}	Nm/arcmin	-	-	-	-	-	
		in.lb/arcmin	-	-	-	-	-	
Max. axial force ^{b)}	F_{2AMax}	N	1900					
		lb _f	428					
Max. radial force ^{c)}	F_{2RMax}	N	4300					
		lb _f	967.5					
Efficiency at full load	η	%	97					
Service life (For calculation, see the Chapter "Information")	L_n	h	> 20000					
Weight incl. standard adapter plate	m	kg	3.3					
		lb _m	7.3					
Operating noise (with $n_1=3000$ rpm no load)	L_{PA}	dB(A)	≤ 72					
Max. permitted housing temperature		°C	+90					
		F	194					
Ambient temperature		°C	-15 to +40					
		F	5 to 104					
Lubrication			Lubricated for life					
Paint			Blue RAL 5002					
Direction of rotation			Motor and gearhead same direction					
Protection class			IP 64					
Moment of inertia (relates to the drive)	24	J_1	kgcm ²	1.8	1.6	1.5	1.5	1.4
			10 ³ in.lb.s ²	1.6	1.4	1.4	1.3	1.3
Clamping hub diameter (mm)	28	J_1	kgcm ²	2.1	1.9	1.8	1.8	1.7
			10 ³ in.lb.s ²	1.9	1.7	1.6	1.6	1.5

^{a)} For higher ambient temperatures, please reduce input speed

^{b)} Refers to center of the output shaft, if $n_2 = 100$ rpm

^{c)} With mounted PLPB+ belt pulley and 100 rpm

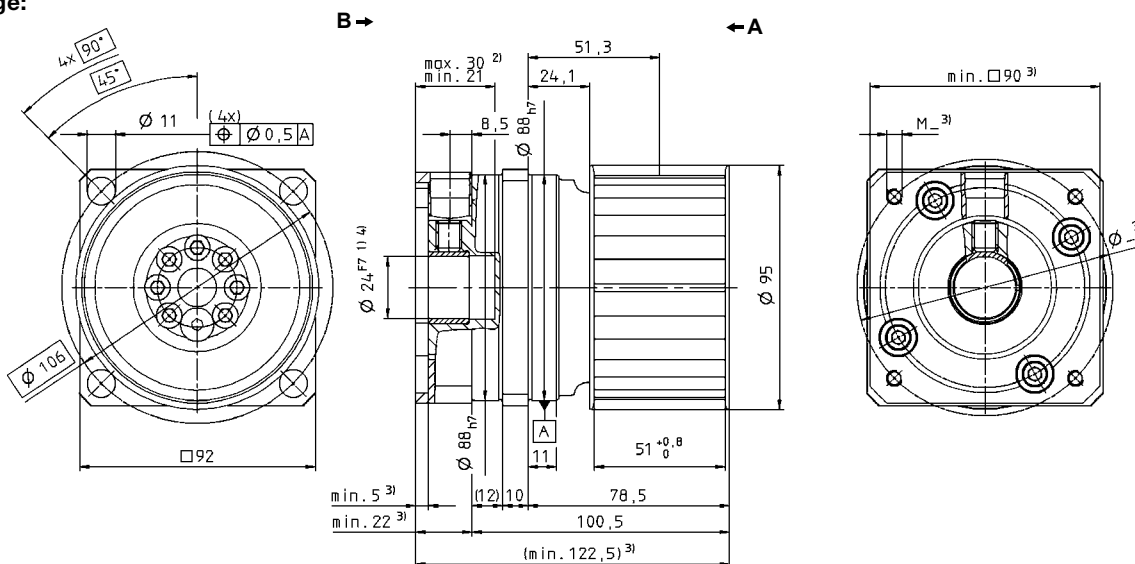
LPB⁺ 1-stage:

Supplement: Belt pulley PLPB⁺ (not in the scope of delivery)

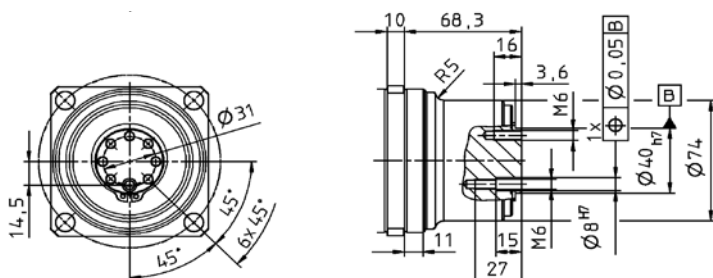

Belt Pulley PLPB ⁺ 090 Profile AT10-0			
Pitch	p	mm	10
Number of teeth	z		28
Circumference	$z * p$	mm/rotation	280
Inertia	J	kgcm ²	10.95
Mass	m	kg	0.82

Non-tolerated dimensions ± 1 mm

- 1) Check motor shaft fit.
- 2) Min./Max. permissible motor shaft length. Longer motor shafts are adaptable, please contact us.
- 3) The dimensions depend on the motor.
- 4) Smaller motor shaft diameter is compensated by a bushing. Motor shaft diameters up to 28mm available – please contact WITTENSTEIN alpha

Motor mounting according to operating manual



LP+ 120 1/2-stage

			1-stage					2-stage									
Ratio	<i>i</i>		3	4	5	7	10	15	16	20	25	30	35	50	70	100	
Max. acceleration torque <small>(max. 1000 cycles per hour)</small>	T_{2B}	Nm	200	220	220	220	200	200	220	220	220	200	220	220	220	200	
		in.lb	1770	1950	1950	1950	1770	1770	1950	1950	1950	1770	1950	1950	1950	1770	
Nominal output torque <small>(with n_{1N})</small>	T_{2N}	Nm	100	110	110	110	100	100	110	110	110	100	110	110	110	100	
		in.lb	890	970	970	970	890	890	970	970	970	890	970	970	970	890	
Emergency stop torque <small>(permitted 1000 times during the service life of the gearhead)</small>	T_{2Not}	Nm	400	480	480	480	480	480	480	480	480	480	480	480	480	480	
		in.lb	3540	4250	4250	4250	4250	4250	4250	4250	4250	4250	4250	4250	4250	4250	
Nominal input speed <small>(with T_{2N} and 20°C ambient temperature)^{a)}</small>	n_{1N}	rpm	2600	2600	2600	2600	2600	2600	2600	2600	2600	2600	2600	2600	2600	2600	
Max. input speed	n_{1Max}	rpm	4800	4800	4800	4800	4800	4800	4800	4800	4800	4800	4800	4800	4800	4800	
Mean no load running torque <small>(with $n_1=3000$ rpm and 20°C gearhead temperature)</small>	T_{012}	Nm	1.1	1.0	0.9	0.8	0.8	0.6	0.6	0.5	0.5	0.4	0.4	0.4	0.4	0.4	
		in.lb	9.7	8.9	8.0	7.1	7.1	5.3	4.9	4.4	4.4	3.5	3.5	3.5	3.5	3.5	
Max. torsional backlash	j_t	arcmin	Standard ≤ 12 / Reduced ≤ 8					Standard ≤ 15 / Reduced ≤ 10									
Torsional rigidity	C_{t21}	<small>Nm/arcmin</small>	22	25	25	25	22	22	25	25	25	22	25	25	25	22	
		<small>in.lb/arcmin</small>	190	220	220	220	190	190	220	220	220	190	220	220	220	190	
Max. axial force ^{b)}	F_{2AMax}	N	4000					4000									
		lb _f	900					900									
Max. radial force ^{b)}	F_{2RMax}	N	4600					4600									
		lb _f	1035					1035									
Efficiency at full load	η	%	97					95									
Service life <small>(For calculation, see the Chapter "Information")</small>	L_n	h	> 20000					> 20000									
Weight incl. standard adapter plate	m	kg	8.6					11.0									
		lb _m	19.0					24.3									
Operating noise <small>(with $n_1=3000$ rpm no load)</small>	L_{PA}	dB(A)	≤ 74														
Max. permitted housing temperature	°C		+90														
	F		194														
Ambient temperature	°C		-15 to +40														
	F		5 to 104														
Lubrication			Lubricated for life														
Paint			Blue RAL 5002														
Direction of rotation			Motor and gearhead same direction														
Protection class			IP 64														
Moment of inertia <small>(relates to the drive)</small>	32	J_1	kgcm ²	6.9	5.9	5.6	5.2	5.1	5.4	5.5	5.5	5.3	5.0	5.3	5.0	5.0	5.0
			10 ⁻³ in.lb.in ²	6.1	5.3	4.9	4.6	4.5	4.7	4.9	4.9	4.7	4.4	4.7	4.4	4.4	4.4
Clamping hub diameter (mm)	38	J_1	kgcm ²	7.8	6.8	6.4	6.1	5.9	6.2	6.4	6.4	6.2	5.9	6.2	5.9	5.9	5.9
			10 ⁻³ in.lb.in ²	6.9	6.0	5.7	5.4	5.2	5.5	5.7	5.7	5.5	5.2	5.5	5.2	5.2	5.2

^{a)} For higher ambient temperatures, please reduce input speed

^{b)} Refers to center of the output shaft, if $n_2 = 100$ rpm

LP+ 1-stage:

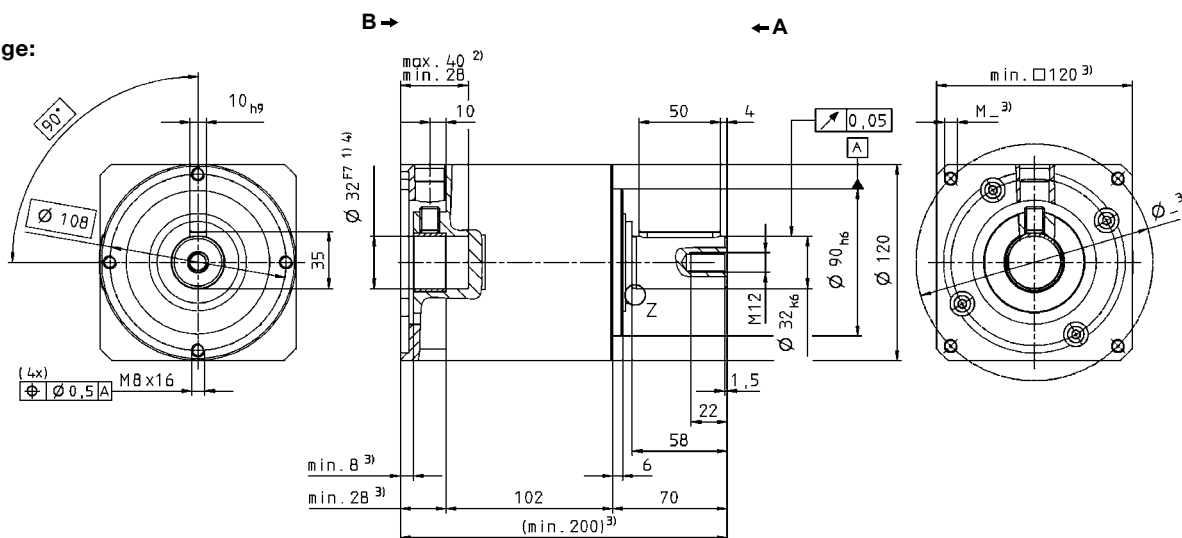

LP+ 2-stage:

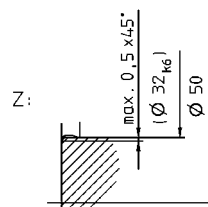
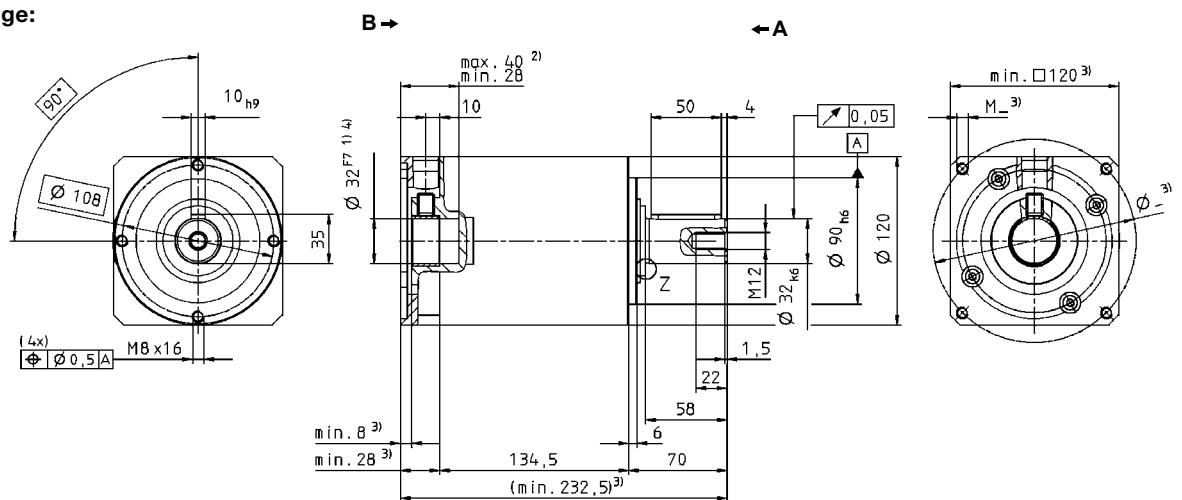

Non-tolerated dimensions $\pm 1\text{mm}$

- 1) Check motor shaft fit.
- 2) Min./Max. permissible motor shaft length. Longer motor shafts are adaptable, please contact us.
- 3) The dimensions depend on the motor.
- 4) Smaller motor shaft diameter is compensated by a bushing. Motor shaft diameters up to 38mm available – please contact WITTENSTEIN alpha



LPB+ 120 1-stage

		1-stage						
Ratio	<i>i</i>		3	4	5	7	10	
Max. acceleration torque (max. 1000 cycles per hour)	T_{2B}	Nm	200	220	220	220	200	
		in.lb	1770	1950	1950	1950	1770	
Nominal output torque (with n_{in})	T_{2N}	Nm	100	110	110	110	100	
		in.lb	890	970	970	970	890	
Emergency stop torque (permitted 1000 times during the service life of the gearhead)	T_{2Not}	Nm	400	480	480	480	480	
		in.lb	3540	4250	4250	4250	4250	
Nominal input speed (with T_{2N} and 20°C ambient temperature ^{a)})	n_{iN}	rpm	2600	2600	2600	2600	2600	
Max. input speed	n_{iMax}	rpm	4800	4800	4800	4800	4800	
Mean no load running torque (with $n_i=3000$ rpm and 20°C gearhead temperature)	T_{012}	Nm	1.1	1.0	0.9	0.8	0.8	
		in.lb	9.7	8.9	8.0	7.1	7.1	
Max. torsional backlash	j_t	arcmin	Standard ≤ 12 / Reduced ≤ 8					
Torsional rigidity	C_{t21}	Nm/ arcmin	-	-	-	-	-	
		in.lb/ arcmin	-	-	-	-	-	
Max. axial force ^{b)}	F_{2AMax}	N	4000					
		lb _f	900					
Max. radial force ^{c)}	F_{2RMax}	N	9500					
		lb _f	2138					
Efficiency at full load	η	%	97					
Service life (For calculation, see the Chapter "Information")	L_n	h	> 20000					
Weight incl. standard adapter plate	m	kg	7.3					
		lb _m	16.1					
Operating noise (with $n_i=3000$ rpm no load)	L_{PA}	dB(A)	≤ 74					
Max. permitted housing temperature		°C	+90					
		F	194					
Ambient temperature		°C	-15 to +40					
		F	5 to 104					
Lubrication			Lubricated for life					
Paint			Blue RAL 5002					
Direction of rotation			Motor and gearhead same direction					
Protection class			IP 64					
Moment of inertia (relates to the drive)	32	J_i	kgcm ²	6.8	5.9	5.6	5.2	5.1
			10 ⁻³ in.lb.s ²	6.1	5.2	4.9	4.6	4.5
Clamping hub diameter (mm)	38	J_i	kgcm ²	7.7	6.8	6.4	6.1	5.9
			10 ⁻³ in.lb.s ²	6.8	6.0	5.7	5.4	5.2

^{a)} For higher ambient temperatures, please reduce input speed

^{b)} Refers to center of the output shaft, if $n_2 = 100$ rpm

^{c)} With mounted PLPB+ belt pulley and 100 rpm

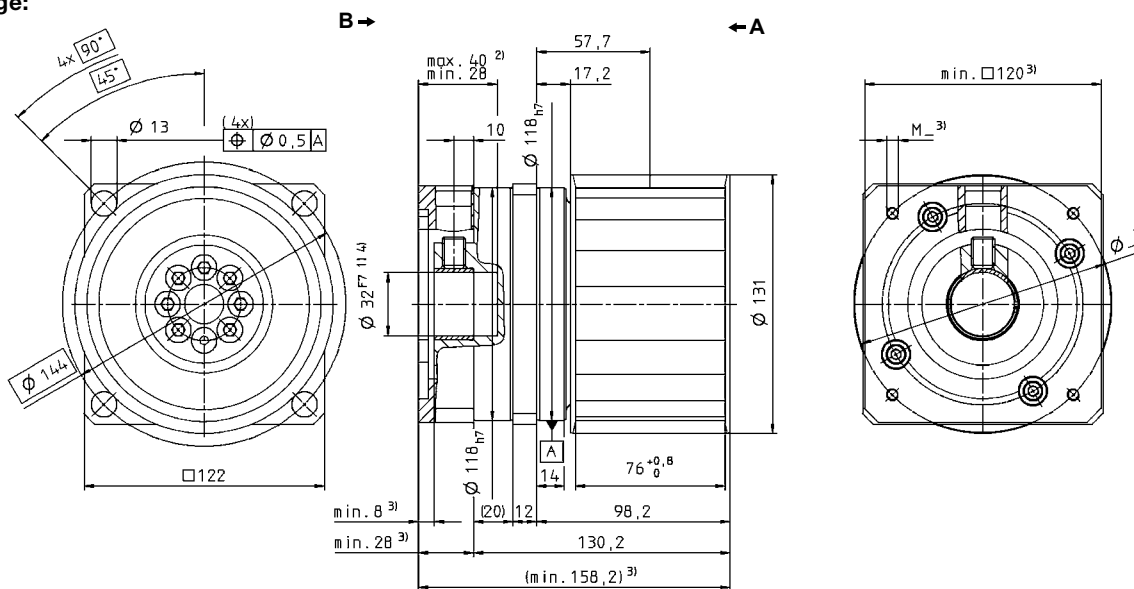
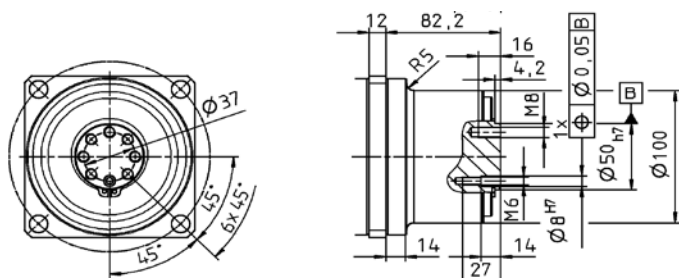
LPB⁺ 1-stage:

 Supplement: Belt pulley PLPB⁺ (not in the scope of delivery)

Belt Pulley PLPB ⁺ 120 Profile AT20-0			
Pitch	p	mm	20
Number of teeth	z		19
Circumference	$z \cdot p$	mm/rotation	380
Inertia	J	kgcm ²	50.62
Mass	m	kg	2.61

 Non-tolerated dimensions ± 1 mm

- 1) Check motor shaft fit.
- 2) Min./Max. permissible motor shaft length. Longer motor shafts are adaptable, please contact us.
- 3) The dimensions depend on the motor.
- 4) Smaller motor shaft diameter is compensated by a bushing. Motor shaft diameters up to 38mm available – please contact WITTENSTEIN alpha

LP+ 155 1/2-stage

Ratio			1-stage			2-stage		
			5	10	25	50	100	
Max. acceleration torque (max. 1000 cycles per hour)	T_{2B}	Nm	450	350	450	450	350	
		in.lb	3980	3100	3980	3980	3100	
Nominal output torque (with n_{1N})	T_{2N}	Nm	320	190	320	320	190	
		in.lb	2830	1680	2830	2830	1680	
Emergency stop torque (permitted 1000 times during the service life of the gearhead)	T_{2Not}	Nm	1000	1000	1000	1000	1000	
		in.lb	8850	8850	8850	8850	8850	
Nominal input speed (with T_{2N} and 20°C ambient temperature ^{a)})	n_{1N}	rpm	2000	2000	2000	2000	2000	
Max. input speed	n_{1Max}	rpm	3600	3600	3600	3600	3600	
Mean no load running torque (with $n_1=3000$ rpm and 20°C gearhead temperature)	T_{012}	Nm	2.8	2.5	1.0	0.8	0.7	
		in.lb	25	22	8.9	7.1	6.2	
Max. torsional backlash	j_t	arcmin	Standard ≤ 12 / Reduced ≤ 8			Standard ≤ 15 / Reduced ≤ 10		
Torsional rigidity	C_{t21}	Nm/arcmin	55	44	55	55	44	
		in.lb/arcmin	490	390	490	490	390	
Max. axial force ^{b)}	F_{2AMax}	N	6000			6000		
		lb _f	1350			1350		
Max. radial force ^{b)}	F_{2RMax}	N	7500			7500		
		lb _f	1688			1688		
Efficiency at full load	η	%	97			95		
Service life (For calculation, see the Chapter "Information")	L_n	h	> 20000			> 20000		
Weight incl. standard adapter plate	m	kg	17.0			21.0		
		lb _m	37.6			46.4		
Operating noise (with $n_1=3000$ rpm no load)	L_{PA}	dB(A)	≤ 75					
Max. permitted housing temperature			°C					
			+90					
Ambient temperature			°C					
			-15 to +40					
Lubrication			F					
			5 to 104					
Paint			Lubricated for life					
Direction of rotation			Blue RAL 5002					
Protection class			Motor and gearhead same direction					
Moment of inertia (relates to the drive)	1-stage: 42	J_1	kgcm ²	17	16	-	-	-
			10 ⁻³ in.lb.s ²	15	14	-	-	-
	2-stage: 32	J_1	kgcm ²	-	-	5.4	5.0	5.0
			10 ⁻³ in.lb.s ²	-	-	4.8	4.4	4.4
Clamping hub diameter (mm)	2-stage: 38	J_1	kgcm ²	-	-	6.3	5.9	5.9
			10 ⁻³ in.lb.s ²	-	-	5.5	5.2	5.2

^{a)} For higher ambient temperatures, please reduce input speed

^{b)} Refers to center of the output shaft, if $n_2 = 100$ rpm

LP+ 1-stage:

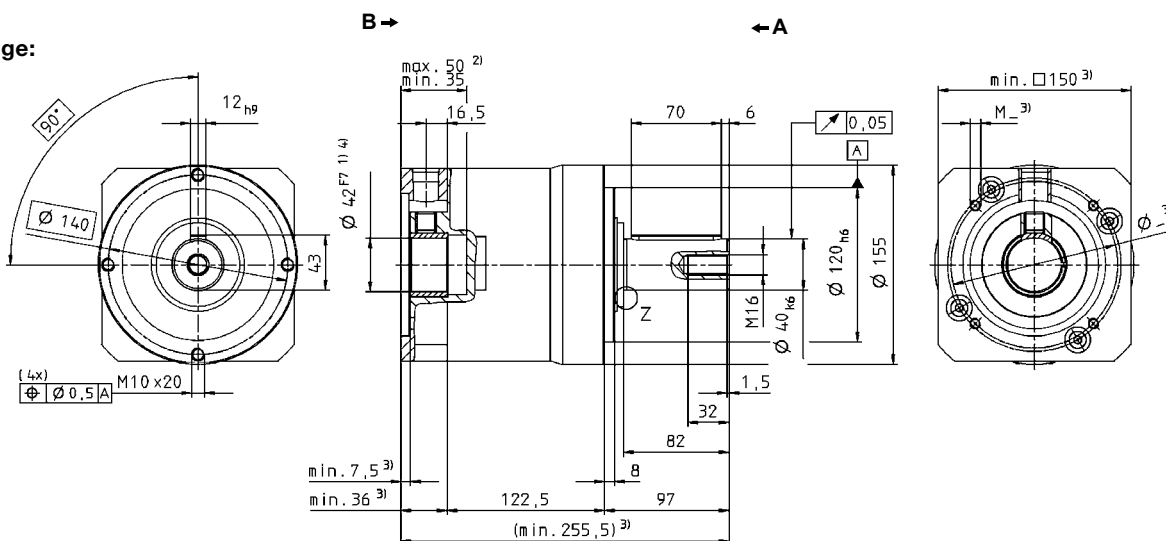

LP+ 2-stage:

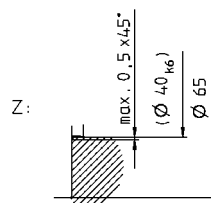
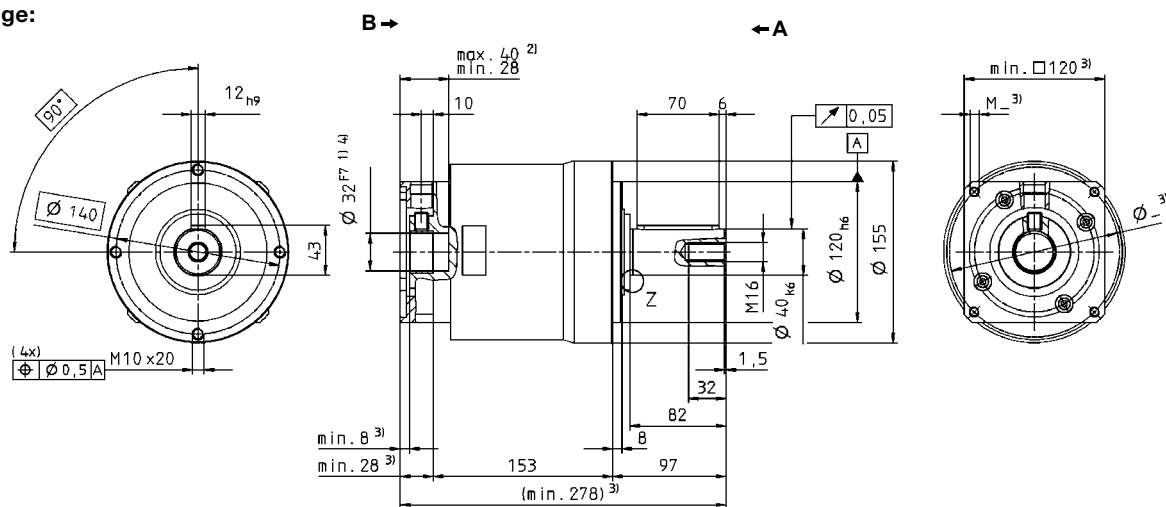

Non-tolerated dimensions $\pm 1\text{mm}$

- 1) Check motor shaft fit.
- 2) Min./Max. permissible motor shaft length. Longer motor shafts are adaptable, please contact us.
- 3) The dimensions depend on the motor.
- 4) Smaller motor shaft diameter is compensated by a bushing.
LP+ 2-stage: Motor shaft diameters up to 38mm available – please contact WITTENSTEIN alpha

Motor mounting according to operating manual



alphira® – Basic precision

The basic class among planetary gearheads



alphira®

Specifications \ Version	alphira®		
	+	++	+++
Positioning accuracy	[Progressive bar chart]		
Rigidity	[Progressive bar chart]		
Smooth-running	[Progressive bar chart]		
Speed capacity	[Progressive bar chart]		
Power density	[Progressive bar chart]		
Max. axial/radial forces	[Progressive bar chart]		



Shrink disc



Visit our online shop at www.alphira.de
(Available in: Germany, Austria, Switzerland)



Couplings



Rack / Pinion

Options

Online shop: www.alphira.de
Food-grade grease 

Accessories

Rack / Pinion (see page 310)
Couplings (see page 342)
NEMA flange
Shrink disc (see page 342)

alpha[®] 040 1/2-stage

		1-stage				2-stage							
Ratio	<i>i</i>	4	5	7	10	16	20	25	35	50	70	100	
Max. acceleration torque (max. 1000 cycles per hour)	T_{2B}	Nm	10.5	11.5	11.5	10.5	10.5	10.5	11.5	11.5	11.5	11.5	10.5
		in.lb	93	102	102	93	93	93	102	102	102	102	93
Nominal output torque (with n_{1N})	T_{2N}	Nm	5.2	5.7	5.7	5.2	5.2	5.2	5.7	5.7	5.7	5.7	5.2
		in.lb	46	50	50	46	46	46	50	50	50	50	46
Emergency stop torque (permitted 1000 times during the service life of the gearhead)	T_{2Not}	Nm	26	26	26	26	26	26	26	26	26	26	26
		in.lb	230	230	230	230	230	230	230	230	230	230	230
Nominal input speed (with T_{2N} and 20°C ambient temperature ^{a)})	n_{1N}	rpm	4000	4000	4000	4000	4000	4000	4000	4000	4000	4000	
Max. input speed	n_{1Max}	rpm	8000	8000	8000	8000	8000	8000	8000	8000	8000	8000	
Mean no load running torque (with $n_1=3000$ rpm and 20°C gearhead temperature)	T_{012}	Nm	0.05	0.05	0.05	0.05	0.05	0.05	0.05	0.05	0.05	0.05	0.05
		in.lb	0.05	0.44	0.44	0.44	0.44	0.44	0.44	0.44	0.44	0.44	0.44
Max. torsional backlash	j_t	arcmin	≤ 20				≤ 25						
Torsional rigidity	C_{t21}	Nm/arcmin	0.58	0.58	0.58	0.52	0.58	0.58	0.58	0.58	0.58	0.58	0.52
		in.lb/arcmin	5.1	5.1	5.1	4.6	5.1	5.1	5.1	5.1	5.1	5.1	4.6
Max. axial force ^{b)}	F_{2AMax}	N	230				230						
		lb _f	51				51						
Max. radial force ^{b)}	F_{2RMax}	N	200				200						
		lb _f	45				45						
Efficiency at full load	η	%	97				95						
Service life (For calculation, see the Chapter "Information")	L_n	h	> 20000				> 20000						
Weight incl. standard adapter plate	m	kg	0.31				0.52						
		lb _m	0.69				1.15						
Operating noise (with $n_1=3000$ rpm no load)	L_{PA}	dB(A)	≤ 66										
Max. permitted housing temperature	°C		+90										
	F		194										
Ambient temperature	°C		-15 to +40										
	F		5 to 104										
Lubrication	Lubricated for life												
Paint	Alu, polished												
Direction of rotation	Motor and gearhead same direction												
Protection class	IP 64												
Moment of inertia (relates to the drive)	J_f	kgcm ²	0.04	0.04	0.04	0.04	0.04	0.04	0.04	0.04	0.04	0.04	0.04
		10 ⁻² in.lb.s ²	0.036	0.036	0.036	0.036	0.036	0.036	0.036	0.036	0.036	0.036	0.036

^{a)} For higher ambient temperatures, please reduce input speed

^{b)} Relates to center of the output shaft or flange, at 100 rpm

1-stage:

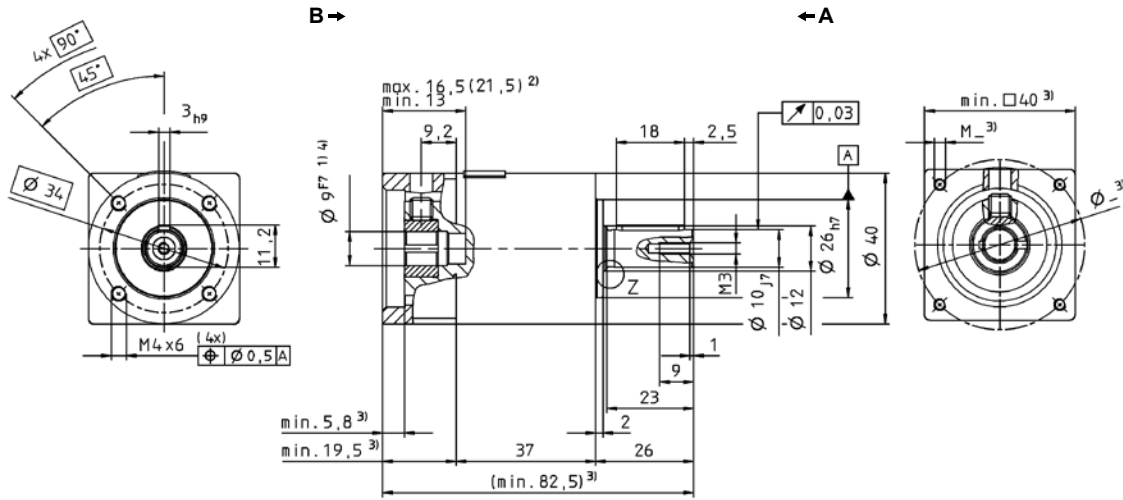

2-stage:

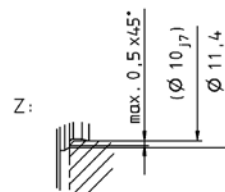
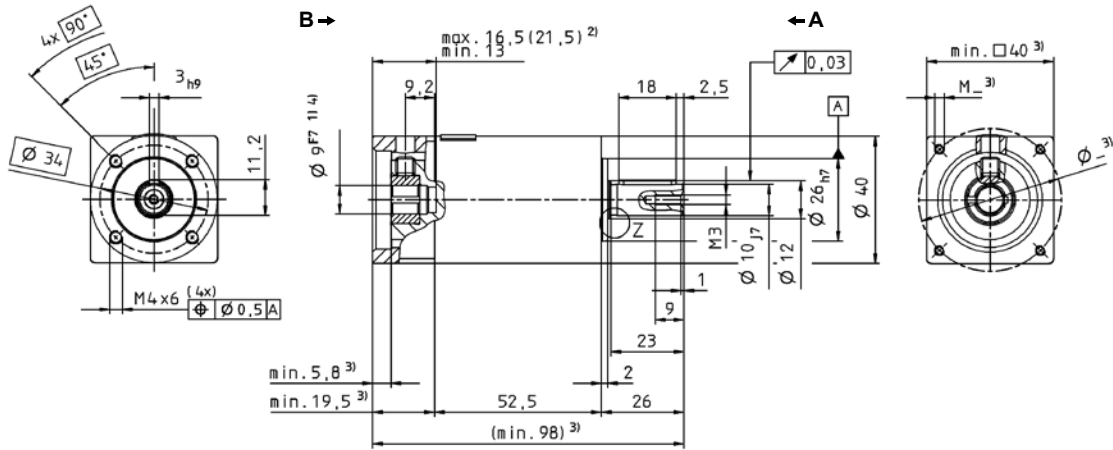

Non-tolerated dimensions ±1mm

- 1) Check motor shaft fit.
- 2) Min./Max. permissible motor shaft length. Longer motor shafts are adaptable, please contact us.
- 3) The dimensions depend on the motor.
- 4) Smaller motor shaft diameter is compensated by a bushing.

⚠ Motor mounting according to operating manual



alphira® 060 1/2-stage

		1-stage				2-stage							
Ratio	<i>i</i>	4	5	7	10	16	20	25	35	50	70	100	
Max. acceleration torque (max. 1000 cycles per hour)	T_{2B}	Nm	32	32	32	29	32	32	32	32	32	32	29
		in.lb	283	283	283	257	283	283	283	283	283	283	257
Nominal output torque (with n_{in})	T_{2N}	Nm	16	16	16	15	16	16	16	16	16	16	15
		in.lb	142	142	142	133	142	142	142	142	142	142	133
Emergency stop torque (permitted 1000 times during the service life of the gearhead)	T_{2Not}	Nm	75	75	75	75	75	75	75	75	75	75	75
		in.lb	664	664	664	664	664	664	664	664	664	664	664
Nominal input speed (with T_{2N} and 20°C ambient temperature ^{a)})	n_{1N}	rpm	3700	3700	3700	3700	3700	3700	3700	3700	3700	3700	
Max. input speed	n_{1Max}	rpm	6000	6000	6000	6000	6000	6000	6000	6000	6000	6000	
Mean no load running torque (with $n_i=3000$ rpm and 20°C gearhead temperature)	T_{012}	Nm	0.11	0.11	0.11	0.11	0.11	0.11	0.11	0.11	0.11	0.11	0.11
		in.lb	0.97	0.97	0.97	0.97	0.97	0.97	0.97	0.97	0.97	0.97	0.97
Max. torsional backlash	j_t	arcmin	≤ 20				≤ 25						
Torsional rigidity	C_{t21}	Nm/arcmin	2.1	2.1	2.1	1.9	2.1	2.1	2.1	2.1	2.1	2.1	1.9
		in.lb/arcmin	19	19	19	17	19	19	19	19	19	19	17
Max. axial force ^{b)}	F_{2AMax}	N	750				750						
		lb _f	169				169						
Max. radial force ^{b)}	F_{2RMax}	N	650				650						
		lb _f	146				146						
Efficiency at full load	η	%	97				95						
Service life (For calculation, see the Chapter "Information")	L_n	h	> 20000				> 20000						
Weight incl. standard adapter plate	m	kg	0.88				1.1						
		lb _m	1.9				2.4						
Operating noise (with $n_i=3000$ rpm no load)	L_{PA}	dB(A)	≤ 68										
Max. permitted housing temperature		°C	+90										
		F	194										
Ambient temperature		°C	-15 to +40										
		F	5 to 104										
Lubrication			Lubricated for life										
Paint			Alu, polished										
Direction of rotation			Motor and gearhead same direction										
Protection class			IP 64										
Moment of inertia (relates to the drive)	J_i	kgcm ²	0.17	0.17	0.17	0.17	0.17	0.17	0.17	0.17	0.17	0.17	0.17
		10 ⁻² in.lb.s ²	0.15	0.15	0.15	0.15	0.15	0.15	0.15	0.15	0.15	0.15	0.15

^{a)} For higher ambient temperatures, please reduce input speed

^{b)} Relates to center of the output shaft or flange, at 100 rpm

1-stage:

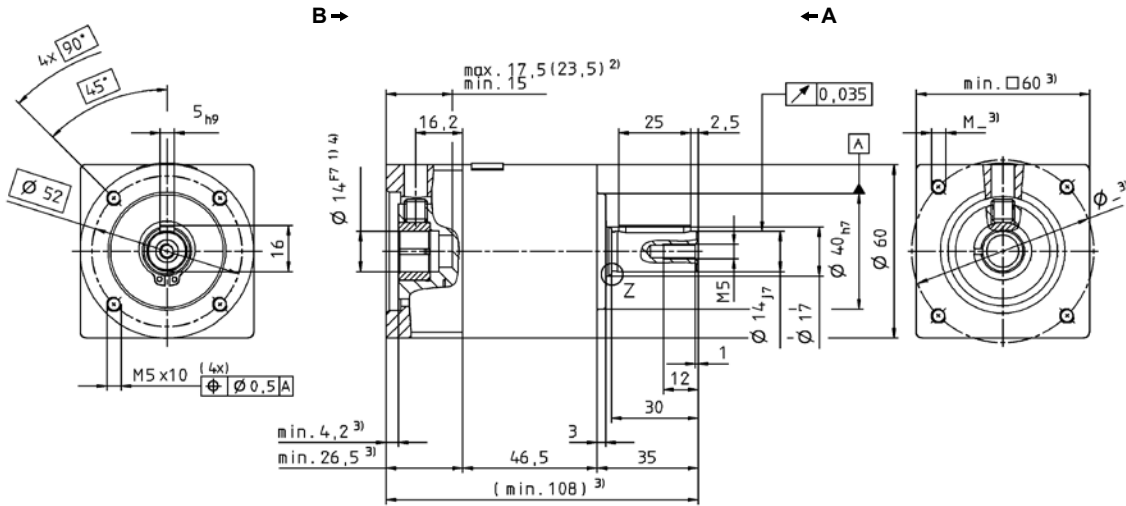

2-stage:

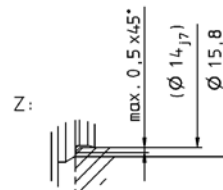
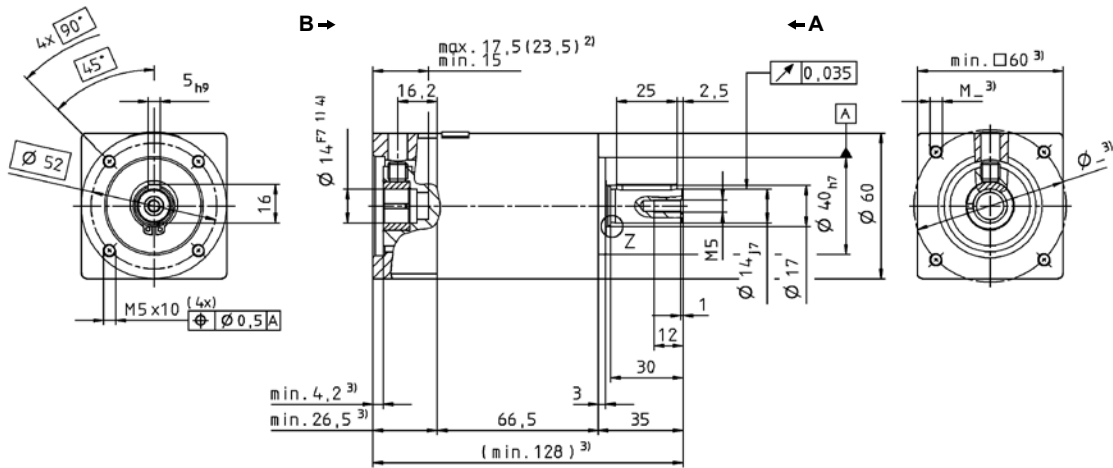

Non-tolerated dimensions $\pm 1\text{mm}$

- 1) Check motor shaft fit.
- 2) Min./Max. permissible motor shaft length. Longer motor shafts are adaptable, please contact us.
- 3) The dimensions depend on the motor.
- 4) Smaller motor shaft diameter is compensated by a bushing.

Motor mounting according to operating manual



alpha[®] 080 1/2-stage

		1-stage				2-stage							
Ratio	<i>i</i>	4	5	7	10	16	20	25	35	50	70	100	
Max. acceleration torque (max. 1000 cycles per hour)	T_{2B}	Nm	80	80	80	72	80	80	80	80	80	80	72
		in.lb	708	708	708	637	708	708	708	708	708	708	637
Nominal output torque (with n_{in})	T_{2N}	Nm	40	40	40	35	40	40	40	40	40	40	35
		in.lb	354	354	354	310	354	354	354	354	354	354	310
Emergency stop torque (permitted 1000 times during the service life of the gearhead)	T_{2Not}	Nm	190	190	190	190	190	190	190	190	190	190	190
		in.lb	1682	1682	1682	1682	1682	1682	1682	1682	1682	1682	1682
Nominal input speed (with T_{2N} and 20°C ambient temperature ^{a)})	n_{iN}	rpm	3400	3400	3400	3400	3400	3400	3400	3400	3400	3400	
Max. input speed	n_{iMax}	rpm	6000	6000	6000	6000	6000	6000	6000	6000	6000	6000	
Mean no load running torque (with $n_i=3000$ rpm and 20°C gearhead temperature)	T_{012}	Nm	0.28	0.28	0.28	0.28	0.28	0.28	0.28	0.28	0.28	0.28	0.28
		in.lb	2.5	2.5	2.5	2.5	2.5	2.5	2.5	2.5	2.5	2.5	2.5
Max. torsional backlash	j_t	arcmin	≤ 20				≤ 25						
Torsional rigidity	C_{t21}	Nm/arcmin	6.1	6.1	6.1	5.5	6.1	6.1	6.1	6.1	6.1	6.1	5.5
		in.lb/arcmin	54	54	54	49	54	54	54	54	54	54	49
Max. axial force ^{b)}	F_{2AMax}	N	1600				1600						
		lb _f	360				360						
Max. radial force ^{b)}	F_{2RMax}	N	1200				1200						
		lb _f	270				270						
Efficiency at full load	η	%	97				95						
Service life (For calculation, see the Chapter "Information")	L_n	h	> 20000				> 20000						
Weight incl. standard adapter plate	m	kg	2.1				2.8						
		lb _m	4.6				6.2						
Operating noise (with $n_i=3000$ rpm no load)	L_{PA}	dB(A)	≤ 70										
Max. permitted housing temperature		°C	+90										
		F	194										
Ambient temperature		°C	-15 to +40										
		F	5 to 104										
Lubrication			Lubricated for life										
Paint			Alu, polished										
Direction of rotation			Motor and gearhead same direction										
Protection class			IP 64										
Moment of inertia (relates to the drive)	J_i	kgcm ²	0.54	0.54	0.54	0.54	0.54	0.54	0.54	0.54	0.54	0.54	0.54
		10 ⁻² in.lb.s ²	0.48	0.48	0.48	0.48	0.48	0.48	0.48	0.48	0.48	0.48	0.48

^{a)} For higher ambient temperatures, please reduce input speed

^{b)} Relates to center of the output shaft or flange, at 100 rpm

1-stage:

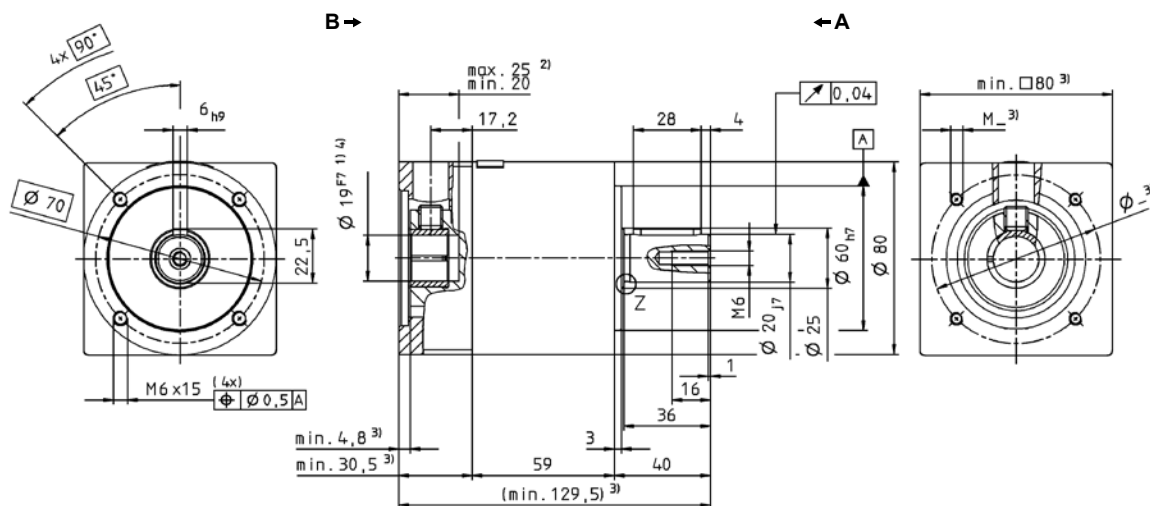

2-stage:

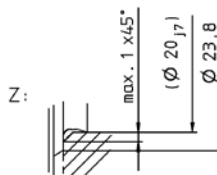
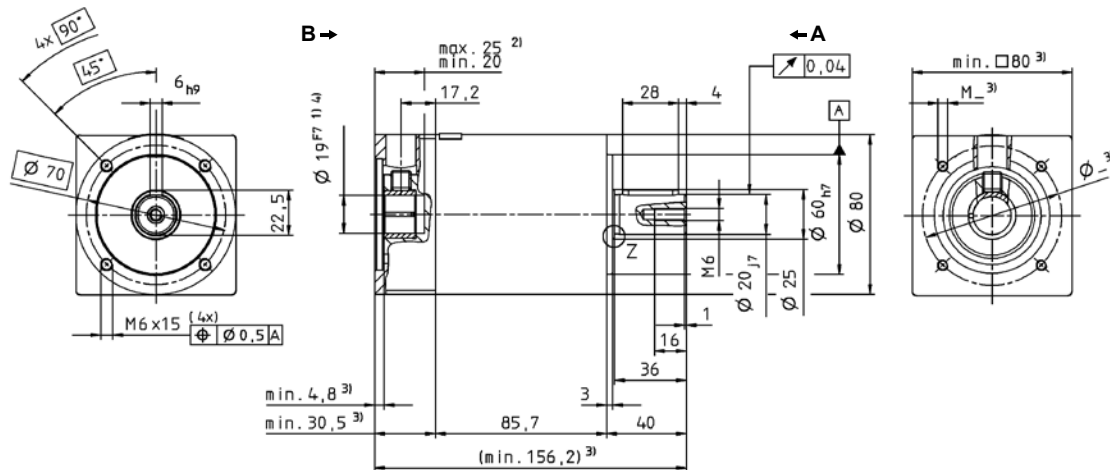

Non-tolerated dimensions $\pm 1\text{mm}$

- 1) Check motor shaft fit.
- 2) Min./Max. permissible motor shaft length. Longer motor shafts are adaptable, please contact us.
- 3) The dimensions depend on the motor.
- 4) Smaller motor shaft diameter is compensated by a bushing.

Motor mounting according to operating manual



alphira® 115 1/2-stage

		1-stage				2-stage							
Ratio	<i>i</i>	4	5	7	10	16	20	25	35	50	70	100	
Max. acceleration torque (max. 1000 cycles per hour)	T_{2B}	Nm	200	200	200	180	200	200	200	200	200	200	180
		in.lb	1770	1770	1770	1593	1770	1770	1770	1770	1770	1770	1593
Nominal output torque (with n_{1N})	T_{2N}	Nm	100	100	100	90	100	100	100	100	100	100	90
		in.lb	885	885	885	797	885	885	885	885	885	885	797
Emergency stop torque (permitted 1000 times during the service life of the gearhead)	T_{2Not}	Nm	480	480	480	480	480	480	480	480	480	480	480
		in.lb	4248	4248	4248	4248	4248	4248	4248	4248	4248	4248	4248
Nominal input speed (with T_{2N} and 20°C ambient temperature ^{a)})	n_{1N}	rpm	2600	2600	2600	2600	2600	2600	2600	2600	2600	2600	
Max. input speed	n_{1Max}	rpm	4800	4800	4800	4800	4800	4800	4800	4800	4800	4800	
Mean no load running torque (with $n_1=3000$ rpm and 20°C gearhead temperature)	T_{012}	Nm	0.5	0.5	0.5	0.5	0.5	0.5	0.5	0.5	0.5	0.5	
		in.lb	4.4	4.4	4.4	4.4	4.4	4.4	4.4	4.4	4.4	4.4	
Max. torsional backlash	j_t	arcmin	≤ 20				≤ 25						
Torsional rigidity	C_{t21}	Nm/arcmin	16.5	16.5	16.5	14.5	16.5	16.5	16.5	16.5	16.5	16.5	14.5
		in.lb/arcmin	146	146	146	128	146	146	146	146	146	146	128
Max. axial force ^{b)}	F_{2AMax}	N	2100				2100						
		lb _f	472				472						
Max. radial force ^{b)}	F_{2RMax}	N	1550				1550						
		lb _f	349				349						
Efficiency at full load	η	%	97				95						
Service life (For calculation, see the Chapter "Information")	L_n	h	> 20000				> 20000						
Weight incl. standard adapter plate	m	kg	5.2				6.9						
		lb _m	11.5				15.2						
Operating noise (with $n_1=3000$ rpm no load)	L_{PA}	dB(A)	≤ 72										
Max. permitted housing temperature		°C	+90										
		F	194										
Ambient temperature		°C	-15 to +40										
		F	5 to 104										
Lubrication			Lubricated for life										
Paint			Alu, polished										
Direction of rotation			Motor and gearhead same direction										
Protection class			IP 64										
Moment of inertia (relates to the drive)	J_f	kgcm ²	1.8	1.8	1.8	1.8	1.8	1.8	1.8	1.8	1.8	1.8	1.8
		10 ⁻² in.lb.s ²	1.6	1.6	1.6	1.6	1.6	1.6	1.6	1.6	1.6	1.6	1.6

^{a)} For higher ambient temperatures, please reduce input speed

^{b)} Relates to center of the output shaft or flange, at 100 rpm

1-stage:

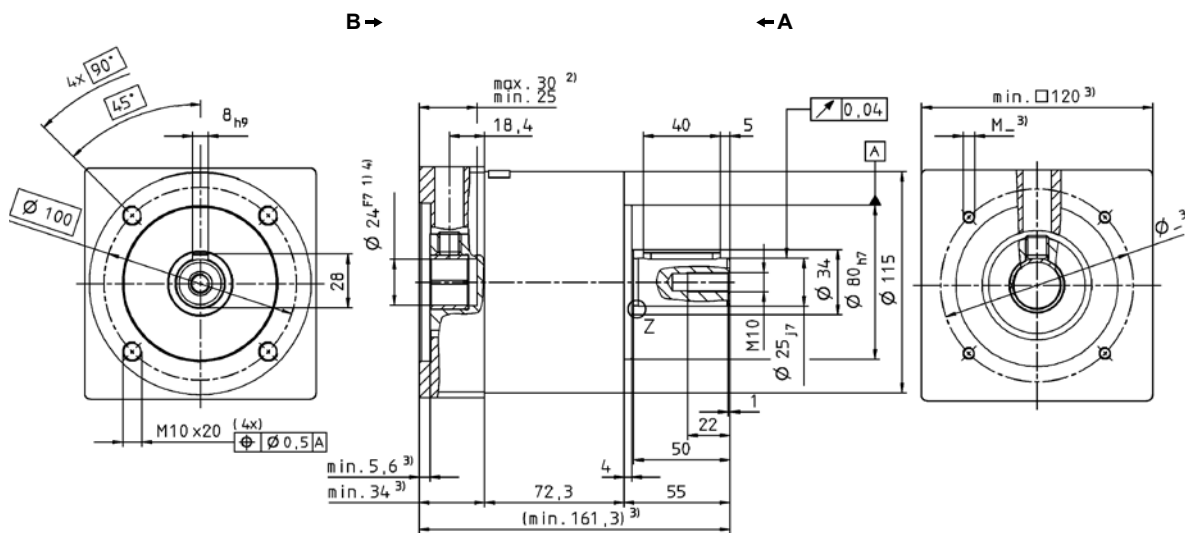

2-stage:

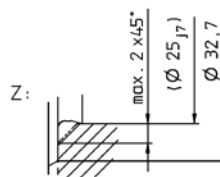
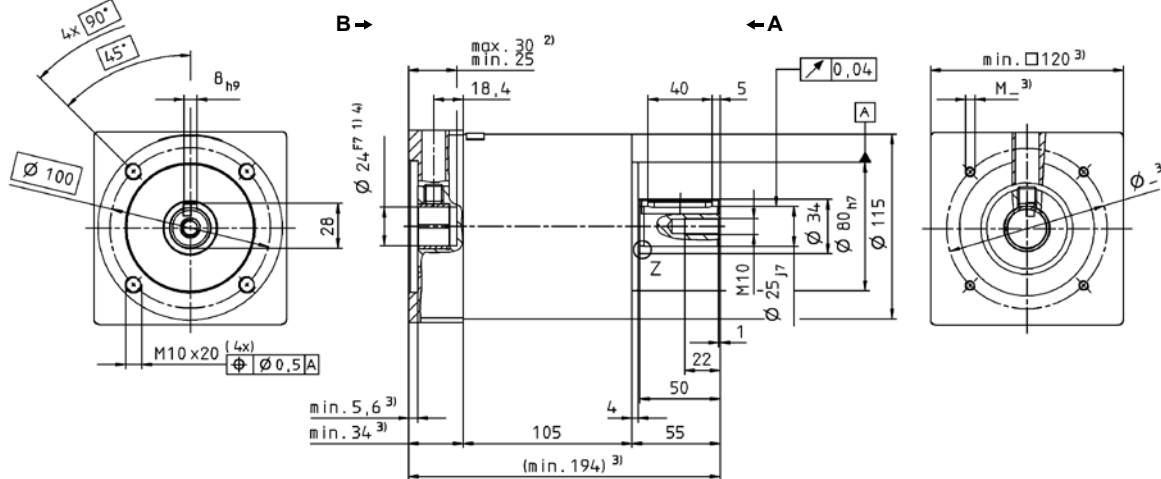

Non-tolerated dimensions $\pm 1\text{mm}$

- 1) Check motor shaft fit.
- 2) Min./Max. permissible motor shaft length. Longer motor shafts are adaptable, please contact us.
- 3) The dimensions depend on the motor.
- 4) Smaller motor shaft diameter is compensated by a bushing.

Motor mounting according to operating manual



Just around the corner – Servo right-angle systems for increased efficiency.

Manufacturers of flexible, high-quality machines with a wide range of functions are extremely demanding when it comes to drive systems: Maximum dynamics and performance density, minimal space and monitoring requirements, extremely smooth-running and robust, simple setup, maintenance-free are just some of the many requirements. Servo right-angle systems by WITTENSTEIN alpha fulfill all these expectations – and even go one step further: Sensational results and an excellent design.



Servo right-angle gearheads

Increased productivity

Do you need a machine that operates at maximum productivity? Your servo right-angle gearhead offers 200 % more torque, 100 % faster speeds than equivalent products and thus creates the perfect conditions for maximum manufacturing efficiency.

SPK⁺

HG⁺

LK⁺

LPK⁺

V-Drive[®]

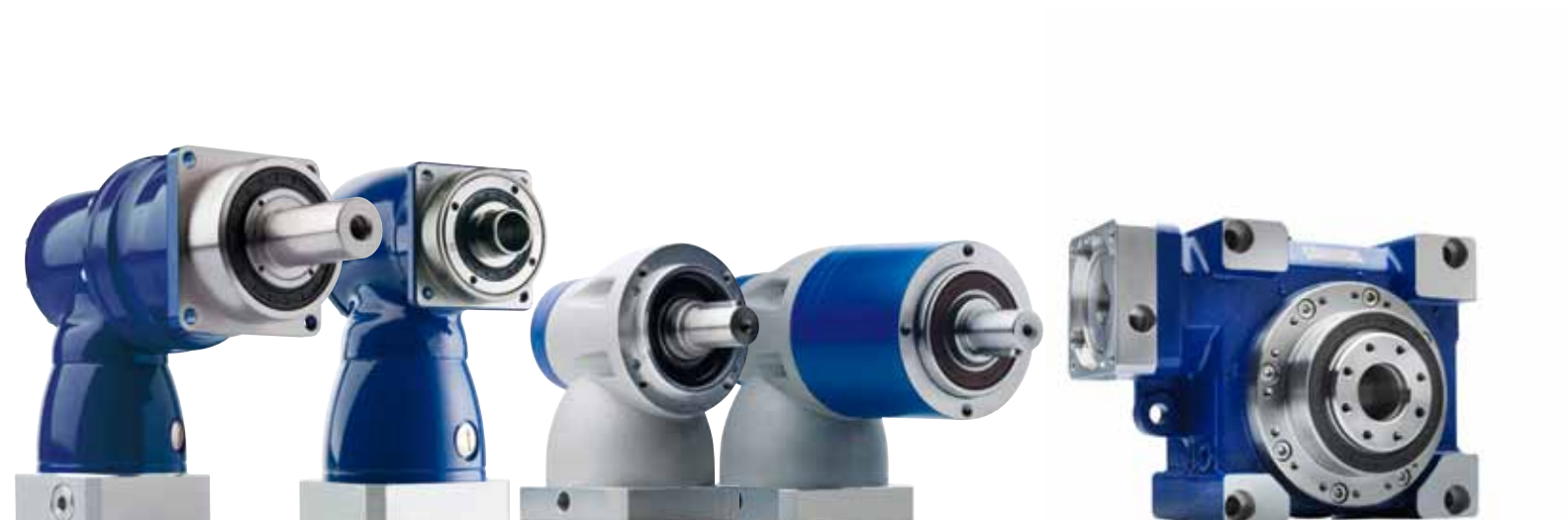

Simple and convenient

From an optimized design with our cymex[®] software to the classic, patented WITTENSTEIN alpha motor attachment and an oil volume adapted to each model – WITTENSTEIN alpha right-angle gearheads make your life so much easier.

Reliable and accurate

The low torsional backlash and high torsional rigidity of your WITTENSTEIN alpha right-angle gearhead assure maximum positioning accuracy of your drives and precision of your machines – even during highly dynamic operation up to 50,000 cycles/hour.

Maximum durability

Your WITTENSTEIN alpha right-angle gearhead is extremely reliable due to the overall design and 100 % WITTENSTEIN alpha inspections: **“fit it and forget it”**. A length compensation feature integrated in your WITTENSTEIN alpha right-angle gearhead as standard maximizes the lifespan of your servo motor during high-speed continuous operation.

The **SPK+/TPK+** High Performance Hypoid gearboxes

Powerful products in the new hypoid range

To guarantee the highest possible productivity of your machine, WITTENSTEIN alpha has enhanced the range of hypoid planetary gearboxes. The newly developed bevel gears are derived from modern hypoid technology in combination with planetary gears with helical gearing. The result is the creation of the best product for maximized performance. With extremely high torque and high ratios we set new standards in the bevel gear market.

WITTENSTEIN alpha moves your world into new dimensions!



All features at a glance:

- Shaft and flange output
- Torques up to 10000 Nm
- Ratios up to $i=10000$
- Efficiency of up to 94 %
- Low noise emission ≤ 71 dB(A)
- High turning torque available up to 9500 Nm
- Highest positioning accuracy with less torsion play and high torsional rigidity
- Optimized seal technology (IP65)
- Flexible position of installation
- Very high input speed up to 4500 rpm

SPK+/TPK+ High Performance Hypoid gearboxes

WITTENSTEIN alpha moves your world into **new dimensions!**

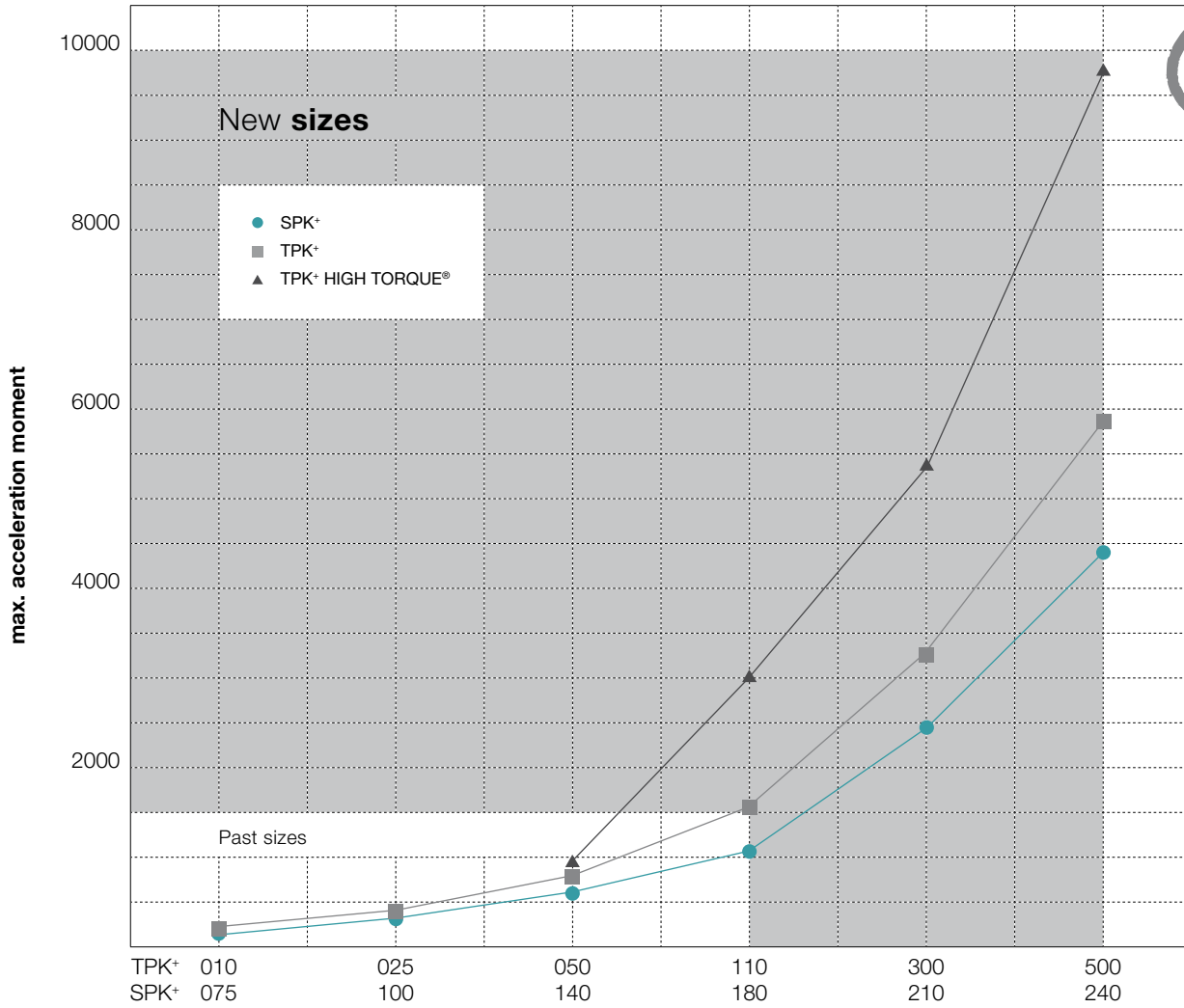

Size

Size	TPK+ SPK+	010 075	025 100	050 140	110 180	300 210	500 240
SPK+	T_{2B} Nm	110	300	600	1100	2500	4500
TPK+	T_{2B} Nm	130	350	750	1600	3300	6000
TPK+ HIGH TORQUE®	T_{2B} Nm	-	-	950	3100	5500	10000



TK+/TPK+ – New right-angle precision

The successor to our versatile hypoid gearhead with TP+ compatible output flange and hollow shaft, with optional planetary stage



TK+/TPK+

Specifications \ Version	TK+/TPK+		
	+	++	+++
Positioning accuracy		TK+	TPK+
Rigidity	TK+		TPK+
Smooth-running		TK+	TPK+
Speed capacity		TK+	TPK+
Power density	TK+		TPK+
Max. axial/radial forces		TK+	TPK+



See our website and our separate flyer for more information about our washdown solutions

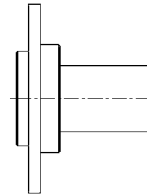

Shaft output



Clamping set



Rack / Pinion

Couplings



TK+ with spindle



Options

- Plug-in drive coupling
- Washdown version
- ATEX version
- Food-grade grease

Accessories

- Rack / Pinion (see page 310)
- Shrink disc (see page 342)
- Coupling: BCT (see page 342)
- TK+ with spindle
- Shaft output

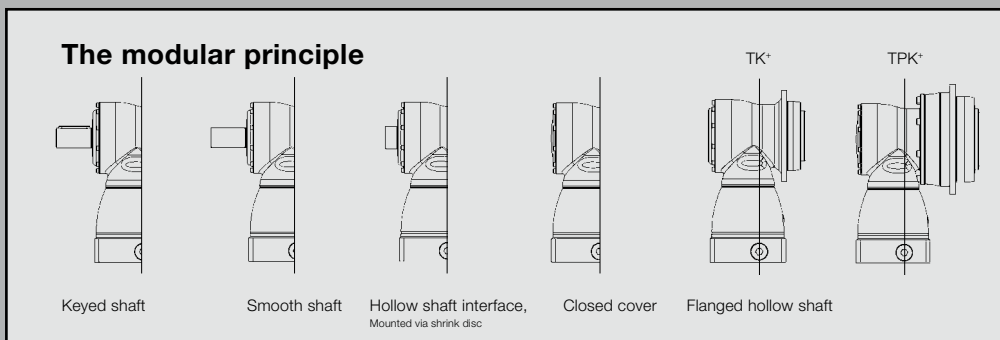

TK+ 004 MF 1/2-stage

		1-stage					2-stage											
Ratio ^{a)}	<i>i</i>	3	4	5	7	10	12	16	20	25	28	35	40	50	70	100		
Max. acceleration torque (max. 1000 cycles per hour)	T_{2B}	Nm	30	30	30	25	20	30	30	30	30	30	30	30	25	20		
		in.lb	266	266	266	221	177	266	266	266	266	266	266	266	266	221	177	
Nominal output torque (with n_{1N})	T_{2N}	Nm	22	22	22	20	15	22	22	22	22	22	22	22	20	15		
		in.lb	195	195	195	177	133	195	195	195	195	195	195	195	195	177	133	
Emergency stop torque (permitted 1000 times during the service life of the gearhead)	T_{2Not}	Nm	40	50	50	45	40	50	50	50	50	50	50	50	45	40		
		in.lb	354	443	443	398	354	443	443	443	443	443	443	443	443	398	354	
Nominal input speed (with T_{2N} and 20 °C ambient temperature) ^{b), c)}	n_{1N}	rpm	2200	2400	2700	2700	2700	4400	4400	4400	4400	4400	4400	4800	5500	5500		
Max. continuous speed (with 20 % T_{2N} and 20 °C ambient temperature)	n_{1Ncym}	rpm	2700	3100	3600	3100	3100	5000	5000	5000	5000	5000	5000	5000	5500	5500		
Max. input speed	n_{1Max}	rpm	6000	6000	6000	6000	6000	6000	6000	6000	6000	6000	6000	6000	6000	6000		
Mean no load running torque (with $n_1=3000$ rpm and 20 °C gearhead temperature) ^{d)}	T_{012}	Nm	1.4	1.3	1.2	1.4	1.3	0.2	0.2	0.2	0.2	0.2	0.2	0.1	0.1	0.1		
		in.lb	12.4	11.5	10.6	12.4	11.5	1.8	1.8	1.8	1.8	1.8	1.8	0.9	0.9	0.9		
Max. torsional backlash	j_t	arcmin	≤ 5															
Torsional rigidity	C_{t21}	Nm/ arcmin	2.6	2.8	3.0	2.6	2.3	2.8	2.8	2.8	2.8	2.8	2.8	2.8	3.0	2.6	2.3	
		in.lb/ arcmin	23	25	26	23	20	25	25	25	25	25	25	25	26	23	20	
Max. axial force ^{e)}	F_{2AMax}	N	2400															
		lb _f	540															
Max. radial force ^{e)}	F_{2RMax}	N	2700															
		lb _f	608															
Max. tilting moment	M_{2KMax}	Nm	251															
		in.lb	2220															
Efficiency at full load	η	%	96					94										
Service life (For calculation, see the Chapter "Information")	L_h	h	> 20000															
Weight incl. standard adapter plate	<i>m</i>	kg	2.9					3.2										
		lb _m	6.4					7.1										
Operating noise (with $n_1=3000$ rpm no load)	L_{PA}	dB(A)	≤ 64															
Max. permitted housing temperature		°C	+90															
		F	194															
Ambient temperature		°C	0 to +40															
		F	32 to 104															
Lubrication			Lubricated for life															
Paint			Blue RAL 5002															
Direction of rotation			Motor and gearhead opposite directions															
Protection class			IP 65															
Moment of inertia (relates to the drive) Clamping hub diameter [mm]	B	11	J_t	kgcm ²	-	-	-	-	-	0.09	0.09	0.08	0.07	0.06	0.06	0.06	0.06	
				10 ⁻³ in.lb.in. ²	-	-	-	-	-	0.08	0.08	0.07	0.07	0.06	0.06	0.05	0.05	0.05
	C	14	J_t	kgcm ²	0.57	0.46	0.41	0.37	0.35	0.21	0.20	0.19	0.19	0.18	0.18	0.17	0.17	0.17
				10 ⁻³ in.lb.in. ²	0.50	0.41	0.36	0.33	0.31	0.18	0.18	0.17	0.16	0.16	0.16	0.15	0.15	0.15
E	19	J_t	kgcm ²	0.92	0.82	0.76	0.72	0.70	-	-	-	-	-	-	-	-		
			10 ⁻³ in.lb.in. ²	0.81	0.72	0.68	0.64	0.62	-	-	-	-	-	-	-	-		

Please contact us for information on the best configuration for S1 conditions of use (continuous operation).

^{a)} Other ratios available on request

^{b)} Higher speeds are possible if the nominal torque is reduced

^{c)} For higher ambient temperatures, please reduce input speed

^{d)} Idling torques decrease during operation

^{e)} Refers to center of the output shaft or flange

All technical data for front output side applies.

Please request information for rear output side versions.

1-stage:

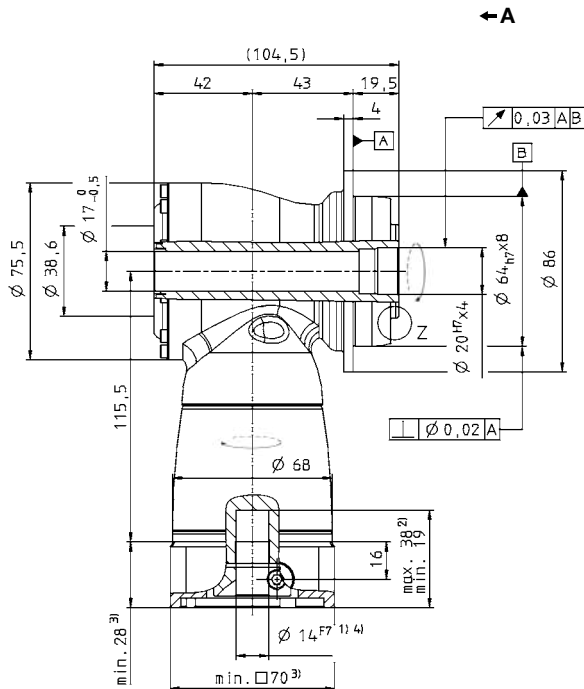
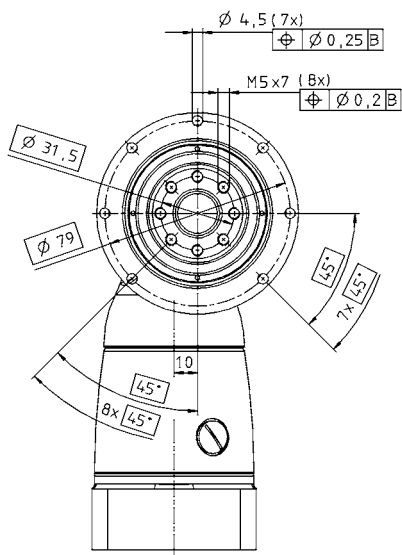

2-stage:

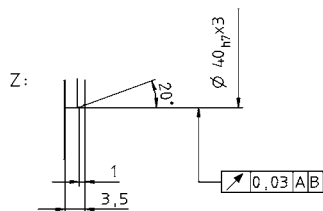
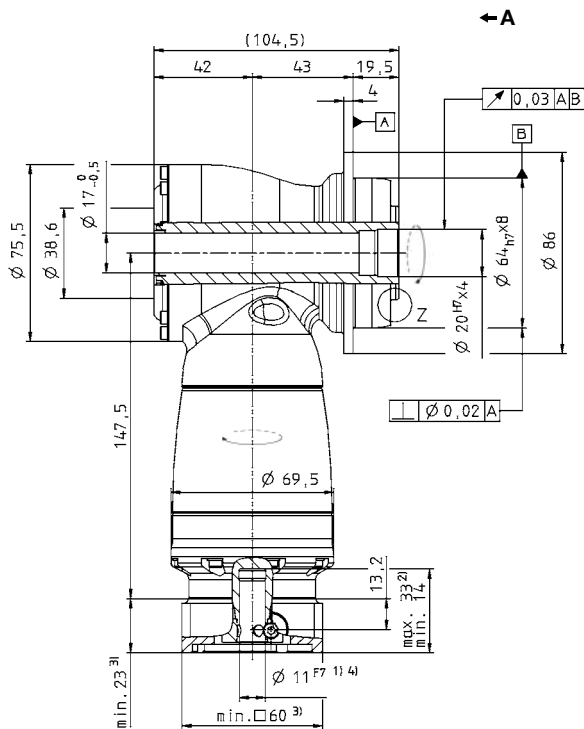
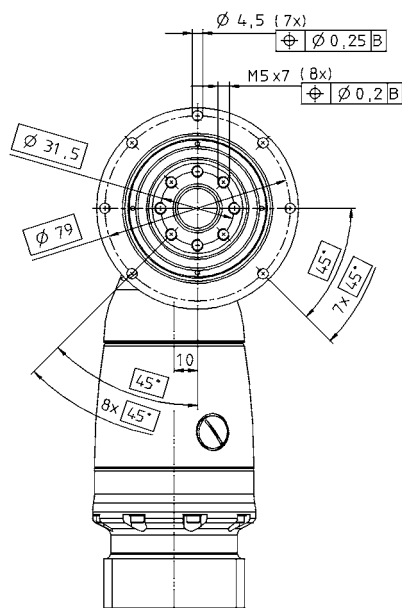

See technical data sheet for available clamping hub diameters (mass moment of inertia). Dimensions available on request.

Non-tolerated dimensions ±1 mm

- 1) Check motor shaft fit.
- 2) Min./Max. permissible motor shaft length. Longer motor shafts are adaptable, please contact us.
- 3) The dimensions depend on the motor.
- 4) Smaller motor shaft diameter is compensated by a bushing with a minimum thickness of 1 mm.

Motor mounting according to operating manual



TK+ 010 MF 1/2-stage

		1-stage					2-stage													
Ratio ^{a)}	<i>i</i>	3	4	5	7	10	12	16	20	25	28	35	40	50	70	100				
Max. acceleration torque (max. 1000 cycles per hour)	T_{2B}	Nm	70	70	70	60	50	70	70	70	70	70	70	70	60	50				
		in.lb	620	620	620	531	443	620	620	620	620	620	620	620	620	531	443			
Nominal output torque (with n_{1N})	T_{2N}	Nm	50	50	50	45	40	50	50	50	50	50	50	50	45	40				
		in.lb	443	443	443	398	354	443	443	443	443	443	443	443	398	354				
Emergency stop torque (permitted 1000 times during the service life of the gearhead)	T_{2Not}	Nm	95	115	115	110	100	115	115	115	115	115	115	115	110	100				
		in.lb	841	1018	1018	974	885	1018	1018	1018	1018	1018	1018	1018	974	885				
Nominal input speed (with T_{2N} and 20 °C ambient temperature) ^{b), c)}	n_{1N}	rpm	2100	2200	2500	2500	2500	3500	3500	3500	3500	3500	3500	3800	4500	4500				
Max. continuous speed (with 20 % T_{2N} and 20 °C ambient temperature)	n_{1Ncym}	rpm	2700	3100	3600	3100	3100	4500	4500	4500	4500	4500	4500	4500	4500	4500				
Max. input speed	n_{1Max}	rpm	6000	6000	6000	6000	6000	6000	6000	6000	6000	6000	6000	6000	6000	6000				
Mean no load running torque (with $n_1=3000$ rpm and 20 °C gearhead temperature) ^{d)}	T_{012}	Nm	2.4	2.0	1.8	2.4	2.2	0.4	0.4	0.3	0.3	0.3	0.3	0.1	0.1	0.1				
		in.lb	21	18	16	21	19	3.5	3.5	2.7	2.7	2.7	2.7	0.9	0.9	0.9				
Max. torsional backlash	j_i	arcmin	≤ 4																	
Torsional rigidity	C_{i21}	Nm/ arcmin	6.0	7.0	8.0	8.0	8.0	7.0	7.0	7.0	7.0	7.0	7.0	7.0	8.0	8.0				
		in.lb/ arcmin	53	62	71	71	71	62	62	62	62	62	62	62	71	71				
Max. axial force ^{e)}	F_{2AMax}	N	3400																	
		lb _f	765																	
Max. radial force ^{e)}	F_{2RMax}	N	4000																	
		lb _f	900																	
Max. tilting moment	M_{2KMax}	Nm	437																	
		in.lb	3867																	
Efficiency at full load	η	%	96					94												
Service life (For calculation, see the Chapter "Information")	L_h	h	> 20000																	
Weight incl. standard adapter plate	<i>m</i>	kg	5.3					6.1												
		lb _m	11.7					13.5												
Operating noise (with $n_1=3000$ rpm no load)	L_{PA}	dB(A)	≤ 66																	
Max. permitted housing temperature		°C	+90																	
		F	194																	
Ambient temperature		°C	0 to +40																	
		F	32 to 104																	
Lubrication			Lubricated for life																	
Paint			Blue RAL 5002																	
Direction of rotation			Motor and gearhead opposite directions																	
Protection class			IP 65																	
Moment of inertia (relates to the drive) Clamping hub diameter [mm]	C	14	J_1	kgcm ²	-	-	-	-	-	0.31	0.28	0.24	0.23	0.21	0.20	0.19	0.18	0.18	0.18	
				10 ⁻³ in.lb.in ²	-	-	-	-	-	0.27	0.25	0.21	0.21	0.18	0.18	0.17	0.16	0.16	0.16	
	E	19	J_1	kgcm ²	1.81	1.39	1.18	1.02	0.93	0.75	0.72	0.68	0.68	0.63	0.63	0.63	0.63	0.63	0.63	0.63
				10 ⁻³ in.lb.in ²	1.60	1.23	1.05	0.90	0.82	0.64	0.64	0.61	0.60	0.59	0.55	0.55	0.56	0.56	0.55	0.55
H	28	J_1	kgcm ²	3.22	2.80	2.60	2.43	2.34	-	-	-	-	-	-	-	-	-	-	-	
			10 ⁻³ in.lb.in ²	2.85	2.48	2.30	2.15	2.07	-	-	-	-	-	-	-	-	-	-	-	

Please contact us for information on the best configuration for S1 conditions of use (continuous operation).

^{a)} Other ratios available on request

^{b)} Higher speeds are possible if the nominal torque is reduced

^{c)} For higher ambient temperatures, please reduce input speed

^{d)} Idling torques decrease during operation

^{e)} Refers to center of the output shaft or flange

All technical data for front output side applies.

Please request information for rear output side versions.

1-stage:

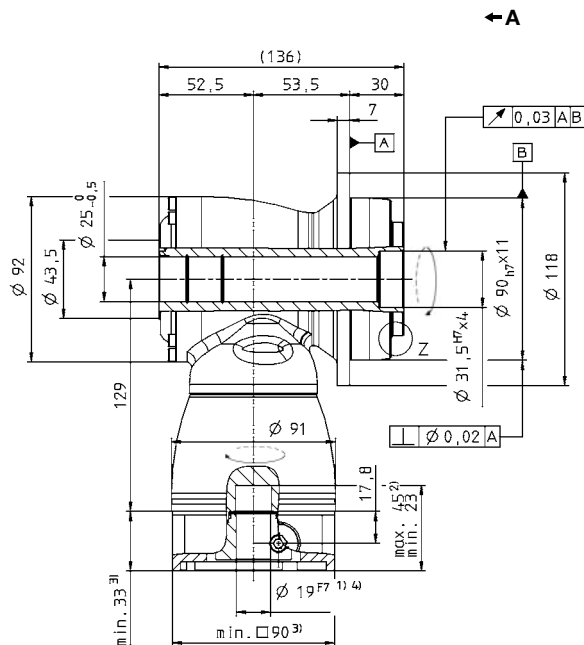
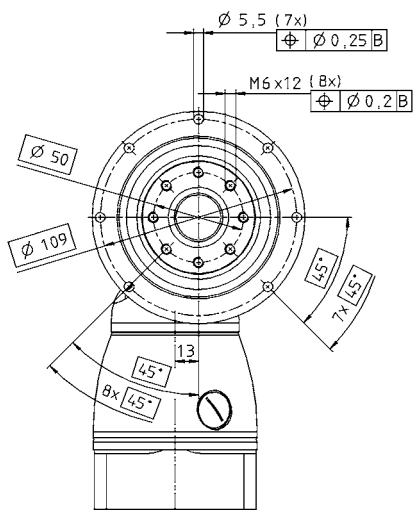

2-stage:

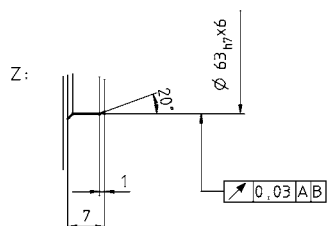
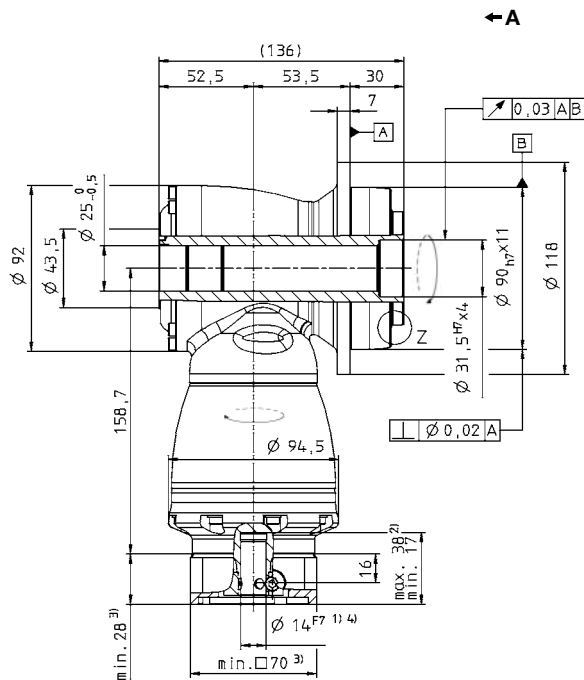
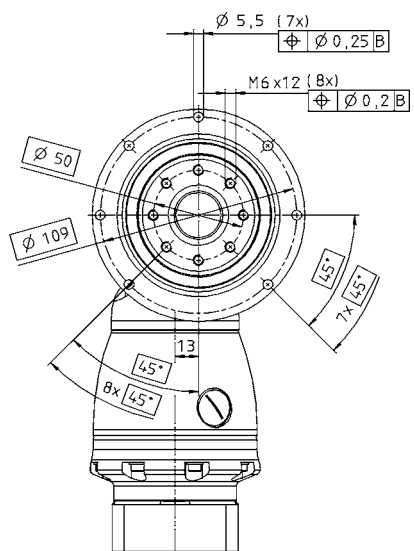

See technical data sheet for available clamping hub diameters (mass moment of inertia). Dimensions available on request.

Non-tolerated dimensions ±1 mm

- 1) Check motor shaft fit.
- 2) Min./Max. permissible motor shaft length. Longer motor shafts are adaptable, please contact us.
- 3) The dimensions depend on the motor.
- 4) Smaller motor shaft diameter is compensated by a bushing with a minimum thickness of 1 mm.

⚠ Motor mounting according to operating manual



TK+ 025 MF 1/2-stage

		1-stage					2-stage												
Ratio ^{a)}	<i>i</i>	3	4	5	7	10	12	16	20	25	28	35	40	50	70	100			
Max. acceleration torque (max. 1000 cycles per hour)	T_{2B}	Nm	170	170	170	145	125	170	170	170	170	170	170	170	145	125			
		in.lb	1505	1505	1505	1283	1106	1505	1505	1505	1505	1505	1505	1505	1283	1106			
Nominal output torque (with n_{1N})	T_{2N}	Nm	100	100	100	90	80	100	100	100	100	100	100	100	90	80			
		in.lb	885	885	885	797	708	885	885	885	885	885	885	885	797	708			
Emergency stop torque (permitted 1000 times during the service life of the gearhead)	T_{2Not}	Nm	220	260	260	255	250	260	260	260	260	260	260	260	260	255	250		
		in.lb	1947	2301	2301	2257	2213	2301	2301	2301	2301	2301	2301	2301	2301	2257	2213		
Nominal input speed (with T_{2N} and 20 °C ambient temperature) ^{b), c)}	n_{1N}	rpm	2000	2100	2400	2200	2200	3100	3100	3100	3100	3100	3100	3500	4200	4200			
Max. continuous speed (with 20 % T_{2N} and 20 °C ambient temperature)	n_{1Ncym}	rpm	2700	3000	3400	3000	3000	4000	4000	4000	4000	4000	4000	4000	4200	4200			
Max. input speed	n_{1Max}	rpm	4500	4500	4500	4500	4500	4500	4500	4500	4500	4500	4500	4500	4500	4500			
Mean no load running torque (with $n_1=3000$ rpm and 20 °C gearhead temperature) ^{d)}	T_{012}	Nm	4.6	3.6	2.8	4.2	3.4	0.7	0.7	0.6	0.5	0.5	0.4	0.2	0.2	0.2			
		in.lb	41	32	25	37	30	6.2	6.2	5.3	4.4	4.4	3.5	1.8	1.8	1.8			
Max. torsional backlash	j_t	arcmin	≤ 4																
Torsional rigidity	C_{t21}	Nm/ arcmin	12	13	16	16	16	13	13	13	13	13	13	13	16	16	16		
		in.lb/ arcmin	106	115	142	142	142	115	115	115	115	115	115	115	142	142	142		
Max. axial force ^{e)}	F_{2AMax}	N	5700																
		lb _f	1283																
Max. radial force ^{e)}	F_{2RMax}	N	6300																
		lb _f	1418																
Max. tilting moment	M_{2KMax}	Nm	833																
		in.lb	7370																
Efficiency at full load	η	%	96					94											
Service life (For calculation, see the Chapter "Information")	L_h	h	> 20000																
Weight incl. standard adapter plate	<i>m</i>	kg	8.9					10.6											
		lb _m	20					23											
Operating noise (with $n_1=3000$ rpm no load)	L_{PA}	dB(A)	≤ 66																
Max. permitted housing temperature			°C																
			F																
Ambient temperature			°C																
			F																
Lubrication			Lubricated for life																
Paint			Blue RAL 5002																
Direction of rotation			Motor and gearhead opposite directions																
Protection class			IP 65																
Moment of inertia (relates to the drive) Clamping hub diameter [mm]	E	19	J_1	kgcm ²	-	-	-	-	-	1.08	1.01	0.88	0.85	0.76	0.75	0.70	0.69	0.69	0.68
				10 ⁻³ in.lb.s ²	-	-	-	-	-	0.96	0.89	0.78	0.75	0.67	0.66	0.62	0.66	0.61	0.60
	G	24	J_1	kgcm ²	-	-	-	-	-	2.65	2.57	2.44	2.42	2.32	2.31	2.26	2.25	2.25	2.25
				10 ⁻³ in.lb.s ²	-	-	-	-	-	2.34	2.28	2.16	2.14	2.06	2.05	2.00	2.00	1.99	1.99
	H	28	J_1	kgcm ²	5.50	4.30	3.60	3.10	2.90	-	-	-	-	-	-	-	-	-	-
				10 ⁻³ in.lb.s ²	4.83	3.77	3.22	2.77	2.54	-	-	-	-	-	-	-	-	-	-
	K	38	J_1	kgcm ²	12.7	11.5	10.9	10.4	10.1	-	-	-	-	-	-	-	-	-	-
				10 ⁻³ in.lb.s ²	11.2	10.2	9.63	9.19	8.95	-	-	-	-	-	-	-	-	-	-

Please contact us for information on the best configuration for S1 conditions of use (continuous operation).

^{a)} Other ratios available on request

^{b)} Higher speeds are possible if the nominal torque is reduced

^{c)} For higher ambient temperatures, please reduce input speed

^{d)} Idling torques decrease during operation

^{e)} Refers to center of the output shaft or flange

All technical data for front output side applies.

Please request information for rear output side versions.

View A

1-stage:

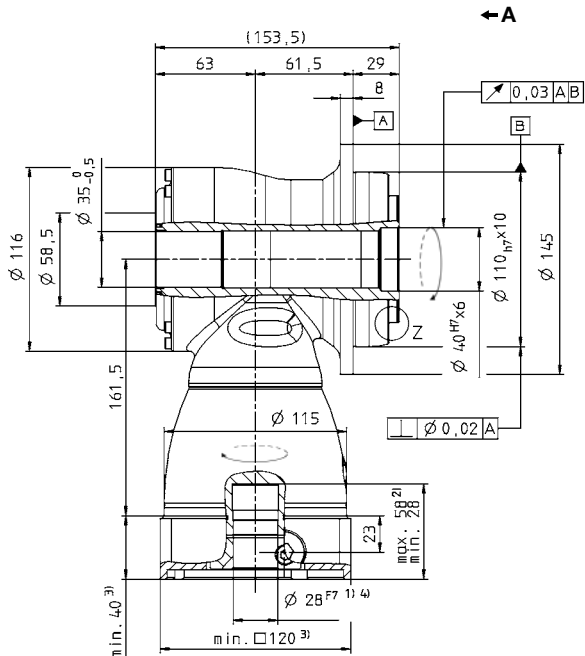
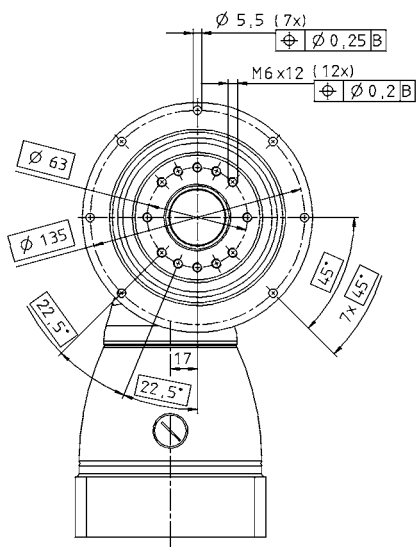

2-stage:

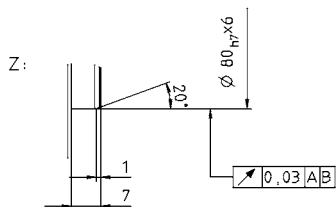
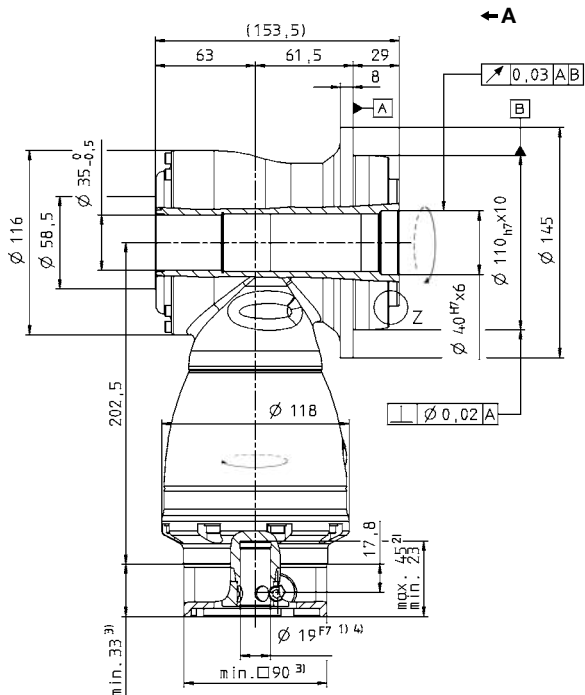
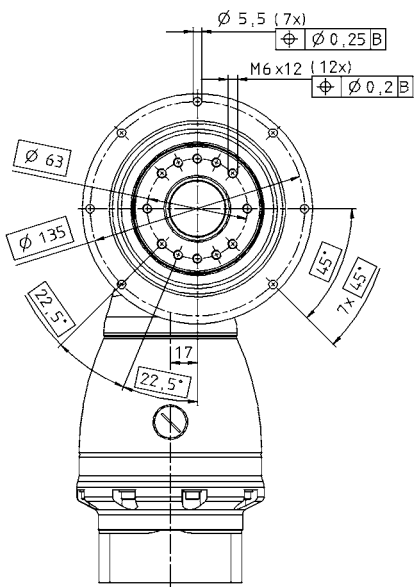

See technical data sheet for available clamping hub diameters (mass moment of inertia). Dimensions available on request.

Non-tolerated dimensions ± 1 mm

- 1) Check motor shaft fit.
- 2) Min./Max. permissible motor shaft length. Longer motor shafts are adaptable, please contact us.
- 3) The dimensions depend on the motor.
- 4) Smaller motor shaft diameter is compensated by a bushing with a minimum thickness of 1 mm.

Motor mounting according to operating manual



TK+ 050 MF 1/2-stage

		1-stage					2-stage												
Ratio ^{a)}	<i>i</i>	3	4	5	7	10	12	16	20	25	28	35	40	50	70	100			
Max. acceleration torque (max. 1000 cycles per hour)	T_{2B}	Nm	300	300	300	250	210	300	300	300	300	300	300	300	250	210			
		in.lb	2655	2655	2655	2213	1859	2655	2655	2655	2655	2655	2655	2655	2213	1859			
Nominal output torque (with n_{1N})	T_{2N}	Nm	190	190	190	175	160	190	190	190	190	190	190	190	175	160			
		in.lb	1682	1682	1682	1549	1416	1682	1682	1682	1682	1682	1682	1682	1549	1416			
Emergency stop torque (permitted 1000 times during the service life of the gearhead)	T_{2Not}	Nm	400	500	500	450	400	500	500	500	500	500	500	500	450	400			
		in.lb	3540	4425	4425	3983	3540	4425	4425	4425	4425	4425	4425	4425	3983	3540			
Nominal input speed (with T_{2N} and 20 °C ambient temperature) ^{b), c)}	n_{1N}	rpm	1700	1800	2000	1800	1800	2900	2900	2900	2900	2900	2900	3200	3200	3900			
Max. continuous speed (with 20 % T_{2N} and 20 °C ambient temperature)	n_{1Nocym}	rpm	2200	2500	2800	2500	2500	4000	4000	4000	4000	4000	4000	4200	4200	4200			
Max. input speed	n_{1Max}	rpm	4500	4500	4500	4500	4500	4500	4500	4500	4500	4500	4500	4500	4500	4500			
Mean no load running torque (with $n_1=3000$ rpm and 20 °C gearhead temperature) ^{d)}	T_{012}	Nm	8.4	6.2	5.4	9.0	6.6	1.7	1.1	0.8	0.6	0.6	0.5	0.5	0.4	0.4			
		in.lb	74	55	48	80	58	15.0	9.7	7.1	5.3	5.3	4.4	4.4	3.5	3.5			
Max. torsional backlash	j_i	arcmin	≤ 4																
Torsional rigidity	C_{i21}	Nm/ arcmin	36	40	46	44	42	40	40	40	40	40	40	40	46	44	42		
		in.lb/ arcmin	315	356	405	387	376	356	356	356	356	356	356	356	405	387	376		
Max. axial force ^{e)}	F_{2AMax}	N	9900																
		lb _f	2228																
Max. radial force ^{e)}	F_{2RMax}	N	9500																
		lb _f	2138																
Max. tilting moment	M_{2KMax}	Nm	1692																
		in.lb	14974																
Efficiency at full load	η	%	96					94											
Service life (For calculation, see the Chapter "Information")	L_h	h	> 20000																
Weight incl. standard adapter plate	<i>m</i>	kg	22					26											
		lb _m	49					57											
Operating noise (with $n_1=3000$ rpm no load)	L_{PA}	dB(A)	≤ 68																
Max. permitted housing temperature			°C																
			F																
Ambient temperature			°C																
			F																
Lubrication			Lubricated for life																
Paint			Blue RAL 5002																
Direction of rotation			Motor and gearhead opposite directions																
Protection class			IP 65																
Moment of inertia (relates to the drive)	G	24	J_1	kgcm ²	-	-	-	-	-	4.43	3.97	3.36	3.22	2.82	2.75	2.50	2.47	2.44	2.42
				10 ⁻³ in.lb.s ²	-	-	-	-	-	3.92	3.51	2.97	2.85	2.50	2.44	2.22	2.18	2.16	2.14
Clamping hub diameter [mm]	K	38	J_1	kgcm ²	28.4	21.0	17.6	14.7	13.1	11.3	10.9	10.3	10.1	9.74	9.66	9.41	9.38	9.35	9.33
				10 ⁻³ in.lb.s ²	25.1	18.6	15.5	13.0	11.6	10.0	9.63	9.09	8.96	8.62	8.55	8.33	8.30	8.28	8.26

Please contact us for information on the best configuration for S1 conditions of use (continuous operation).

- ^{a)} Other ratios available on request
- ^{b)} Higher speeds are possible if the nominal torque is reduced
- ^{c)} For higher ambient temperatures, please reduce input speed
- ^{d)} Idling torques decrease during operation
- ^{e)} Refers to center of the output shaft or flange

All technical data for front output side applies.
Please request information for rear output side versions.

View A

1-stage:

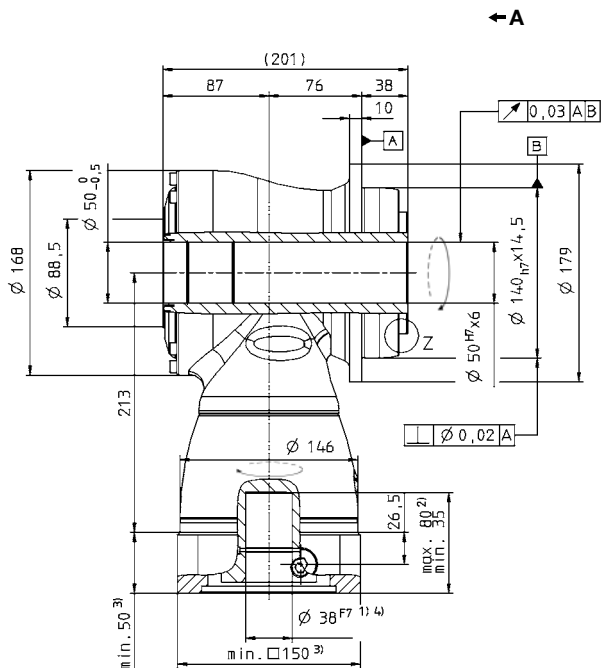
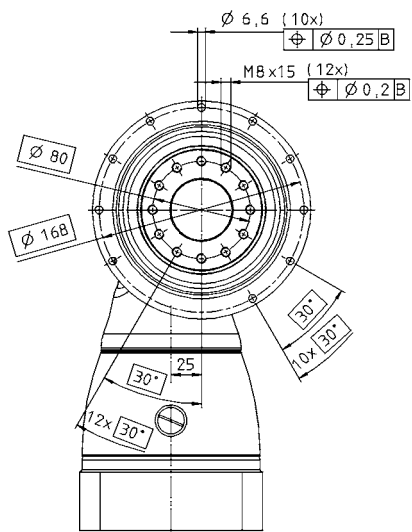

2-stage:

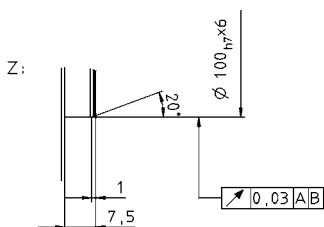
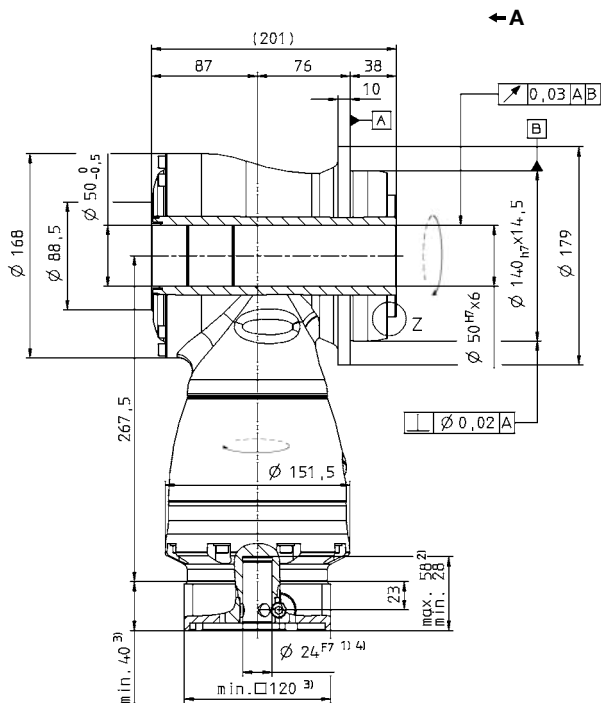
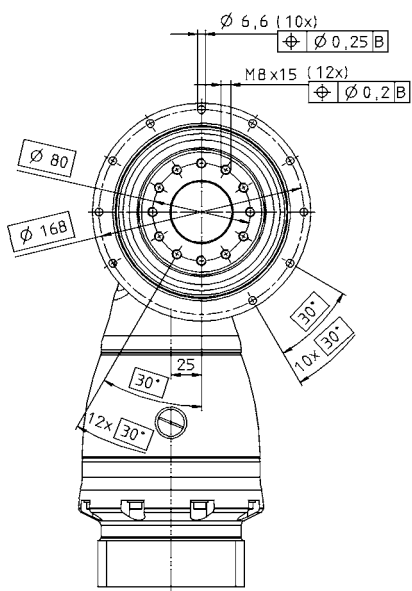

See technical data sheet for available clamping hub diameters (mass moment of inertia). Dimensions available on request.

Non-tolerated dimensions ± 1 mm

- 1) Check motor shaft fit.
- 2) Min./Max. permissible motor shaft length. Longer motor shafts are adaptable, please contact us.
- 3) The dimensions depend on the motor.
- 4) Smaller motor shaft diameter is compensated by a bushing with a minimum thickness of 1 mm.

Motor mounting according to operating manual



TK+ 110 MF 1/2-stage

		1-stage					2-stage												
Ratio ^{a)}	<i>i</i>	3	4	5	7	10	12	16	20	25	28	35	40	50	70	100			
Max. acceleration torque (max. 1000 cycles per hour)	T_{2B}	Nm	640	640	640	550	470	640	640	640	640	640	640	640	640	550	470		
		in.lb	5664	5664	5664	4868	4160	5664	5664	5664	5664	5664	5664	5664	5664	4868	4160		
Nominal output torque (with n_{1N})	T_{2N}	Nm	400	400	400	380	360	400	400	400	400	400	400	400	400	380	360		
		in.lb	3540	3540	3540	3363	3186	3540	3540	3540	3540	3540	3540	3540	3540	3363	3186		
Emergency stop torque (permitted 1000 times during the service life of the gearhead)	T_{2Not}	Nm	900	1050	1050	970	900	1050	1050	1050	1050	1050	1050	1050	1050	970	900		
		in.lb	7965	9293	9293	8585	7965	9293	9293	9293	9293	9293	9293	9293	9293	8585	7965		
Nominal input speed (with T_{2N} and 20 °C ambient temperature) ^{b), c)}	n_{1N}	rpm	1400	1600	1800	1600	1600	2700	2700	2700	2700	2700	2700	2700	2900	3200	3400		
Max. continuous speed (with 20 % T_{2N} and 20 °C ambient temperature)	n_{1Ncym}	rpm	1800	2100	2500	2200	2200	3500	3500	3500	3500	3500	3500	3500	3500	3800	3800		
Max. input speed	n_{1Max}	rpm	4000	4000	4000	4000	4000	4000	4000	4000	4000	4000	4000	4000	4000	4000	4000		
Mean no load running torque (with $n_1=3000$ rpm and 20 °C gearhead temperature) ^{d)}	T_{012}	Nm	17.5	14.5	12.0	18.0	15.0	3.6	2.8	2.2	1.9	1.6	1.4	1.1	1.1	1.1	1.1		
		in.lb	155	128	106	159	133	31.9	24.8	19.5	16.8	14.2	12.4	9.7	9.7	9.7	9.7		
Max. torsional backlash	j_i	arcmin	≤ 4																
Torsional rigidity	C_{t21}	Nm/arcmin	76	87	99	97	96	87	87	87	87	87	87	87	99	97	96		
		in.lb/arcmin	676	766	874	860	847	766	766	766	766	766	766	766	766	874	860	847	
Max. axial force ^{e)}	F_{2AMax}	N	14200																
		lb _f	3195																
Max. radial force ^{e)}	F_{2RMax}	N	14700																
		lb _f	3308																
Max. tilting moment	M_{2KMax}	Nm	3213																
		in.lb	28435																
Efficiency at full load	η	%	96					94											
Service life (For calculation, see the Chapter "Information")	L_h	h	> 20000																
Weight incl. standard adapter plate	<i>m</i>	kg	48					54											
		lb _m	106					119											
Operating noise (with $n_1=3000$ rpm no load)	L_{PA}	dB(A)	≤ 68																
Max. permitted housing temperature		°C	+90																
		F	194																
Ambient temperature		°C	0 to +40																
		F	32 to 104																
Lubrication			Lubricated for life																
Paint			Blue RAL 5002																
Direction of rotation			Motor and gearhead opposite directions																
Protection class			IP 65																
Moment of inertia (relates to the drive) Clamping hub diameter [mm]	K	38	J_1	kgcm ²	-	-	-	-	-	16.8	14.8	12.9	12.3	11.2	10.9	10.3	10.1	10.0	9.93
				10 ⁻³ in.lb.in ²	-	-	-	-	-	14.8	13.1	11.4	10.9	9.88	9.63	9.08	8.95	8.84	8.79
	M	48	J_1	kgcm ²	96.5	64.6	50.5	38.2	31.8	31.5	29.5	27.6	27.0	25.9	25.6	25.0	24.8	24.7	24.6
				10 ⁻³ in.lb.in ²	85.4	57.2	44.7	33.8	28.1	27.9	26.1	24.4	23.9	22.9	22.6	22.1	22.0	21.9	21.8

Please contact us for information on the best configuration for S1 conditions of use (continuous operation).

- ^{a)} Other ratios available on request
- ^{b)} Higher speeds are possible if the nominal torque is reduced
- ^{c)} For higher ambient temperatures, please reduce input speed
- ^{d)} Idling torques decrease during operation
- ^{e)} Refers to center of the output shaft or flange

All technical data for front output side applies.
Please request information for rear output side versions.

View A

1-stage:

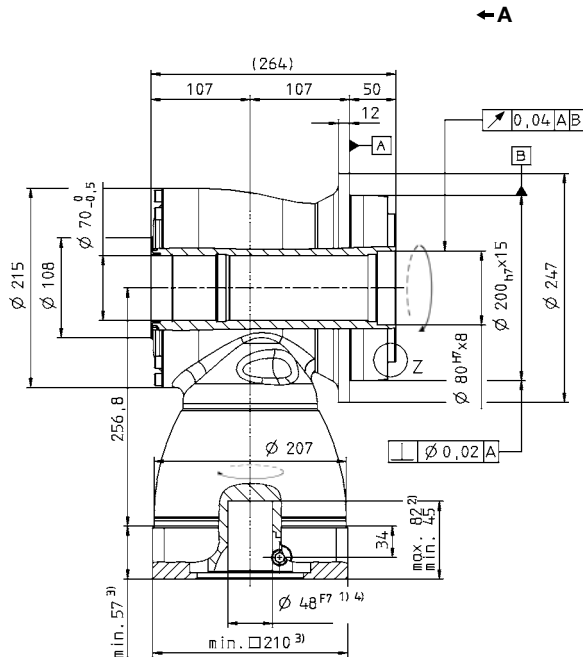
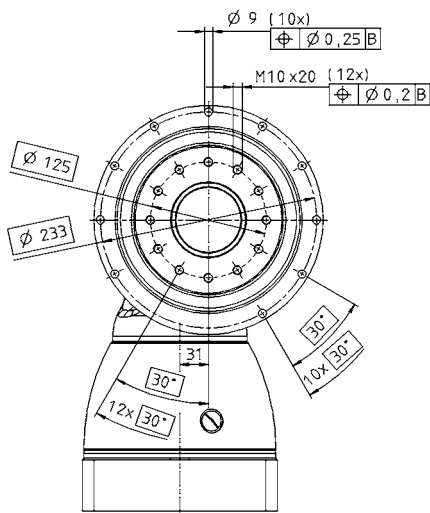

2-stage:

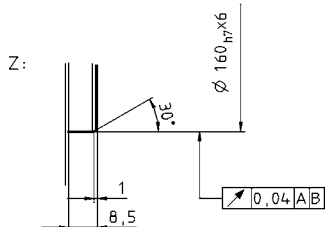
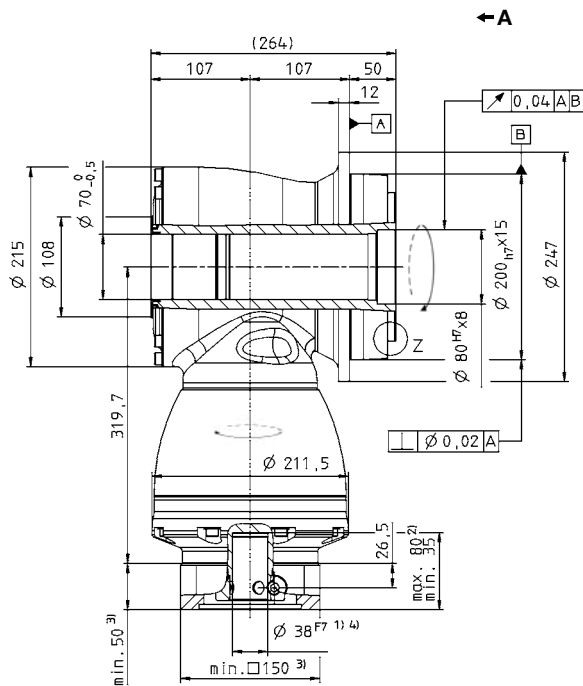
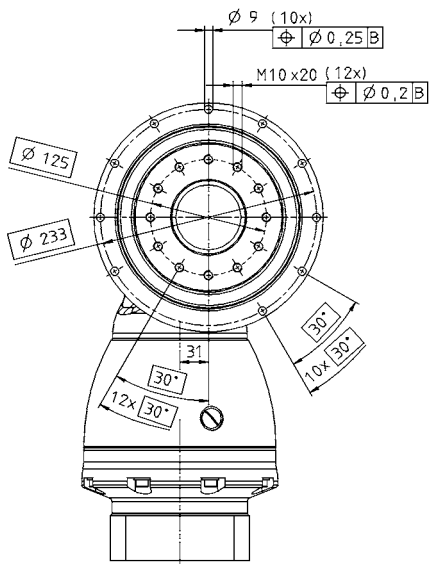

See technical data sheet for available clamping hub diameters (mass moment of inertia). Dimensions available on request.

Non-tolerated dimensions ± 1 mm

- 1) Check motor shaft fit.
- 2) Min./Max. permissible motor shaft length. Longer motor shafts are adaptable, please contact us.
- 3) The dimensions depend on the motor.
- 4) Smaller motor shaft diameter is compensated by a bushing with a minimum thickness of 1 mm.

Motor mounting according to operating manual



TPK+ 010 MF 2-stage

		2-stage													
Ratio ^{a)}	<i>i</i>		12	16	20	25	28	35	40	49	50	70	100		
Max. acceleration torque (max. 1000 cycles per hour)	T_{2B}	Nm	120	120	130	130	130	130	80	130	100	130	100		
		in.lb	1.062	1.062	1.151	1.151	1.151	1.151	708	1.151	885	1.151	885		
Nominal output torque (with n_m)	T_{2N}	Nm	75	75	75	75	75	75	60	75	75	75	60		
		in.lb	664	664	664	664	664	664	531	664	664	664	531		
Emergency stop torque (permitted 1000 times during the service life of the gearhead)	T_{2Not}	Nm	160	200	250	250	250	250	160	250	200	250	250		
		in.lb	1416	1770	2213	2213	2213	2213	1416	2213	1770	2213	2213		
Nominal input speed (with T_{2N} and 20 °C ambient temperature) ^{b), c)}	n_{1N}	rpm	2000	2400	2400	2700	2400	2500	2500	2500	2500	2500	2500		
Max. continuous speed (with 20 % T_{2N} and 20 °C ambient temperature)	n_{1Ncym}	rpm	3000	3400	3400	3800	3400	3200	3200	3200	3200	3200	3200		
Max. input speed	n_{1Max}	rpm	6000	6000	6000	6000	6000	6000	6000	6000	6000	6000	6000		
Mean no load running torque (with $n_1=3000$ rpm and 20 °C gearhead temperature) ^{d)}	T_{012}	Nm	1.5	1.3	1.2	1.2	1.2	1.3	1.3	1.3	1.3	1.3	1.3		
		in.lb	13.3	11.5	10.6	10.6	10.6	11.5	11.5	11.5	11.5	11.5	11.5		
Max. torsional backlash	j_t	arcmin	Standard ≤ 5 / Reduced ≤ 3												
Torsional rigidity	C_{t21}	Nm/ arcmin	16	16	20	21	23	24	15	23	19	22	27		
		in.lb/ arcmin	142	142	177	186	204	212	133	204	168	195	239		
Tilting rigidity	C_{2K}	Nm/ arcmin	225												
		in.lb/ arcmin	1991												
Max. axial force ^{e)}	F_{2AMax}	N	2150												
		lb _f	484												
Max. tilting moment	M_{2KMax}	Nm	235												
		in.lb	2080												
Efficiency at full load	η	%	94												
Service life (For calculation, see the Chapter "Information")	L_n	h	> 20000												
Weight incl. standard adapter plate	<i>m</i>	kg	5.2												
		lb _m	11.5												
Operating noise (with $n_1=3000$ rpm no load)	L_{PA}	dB(A)	≤ 66												
Max. permitted housing temperature		°C	+90												
		F	194												
Ambient temperature		°C	0 to +40												
		F	32 to 104												
Lubrication			Lubricated for life												
Paint			Blue RAL 5002												
Direction of rotation			Motor and gearhead opposite directions												
Protection class			IP 65												
Moment of inertia (relates to the drive) Clamping hub diameter [mm]	C	14	J_1	kgcm ²	0.55	0.46	0.44	0.39	0.43	0.36	0.34	0.37	0.34	0.34	0.34
				10 ⁻³ in.lb.in. ²	0.49	0.40	0.39	0.35	0.38	0.32	0.30	0.33	0.30	0.30	0.30
	E	19	J_1	kgcm ²	0.90	0.81	0.79	0.75	0.78	0.71	0.70	0.72	0.70	0.69	0.69
				10 ⁻³ in.lb.in. ²	0.80	0.72	0.70	0.66	0.69	0.63	0.62	0.64	0.62	0.61	0.61

Please contact us for information on the best configuration for S1 conditions of use (continuous operation).

- ^{a)} Other ratios up to $i=1000$ available on request
- ^{b)} Higher speeds are possible if the nominal torque is reduced
- ^{c)} For higher ambient temperatures, please reduce input speed
- ^{d)} Idling torques decrease during operation
- ^{e)} Refers to center of the output shaft or flange

All technical data for front output side applies.
Please request information for rear output side versions.

View A

2-stage:

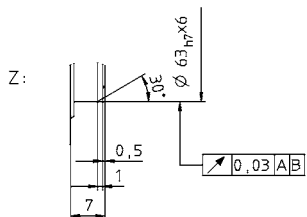
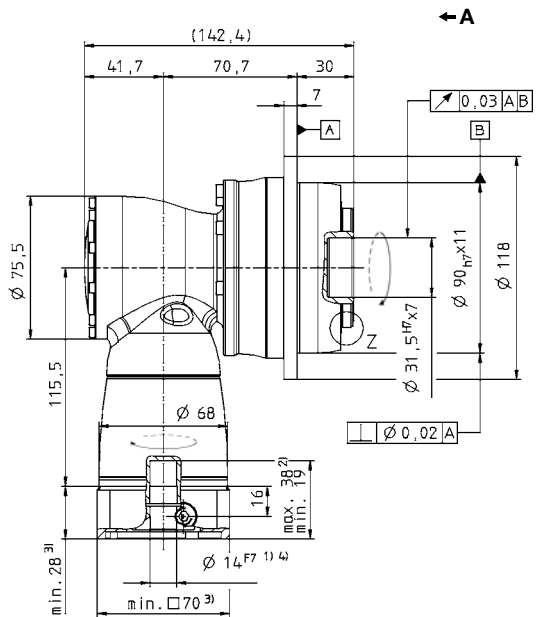
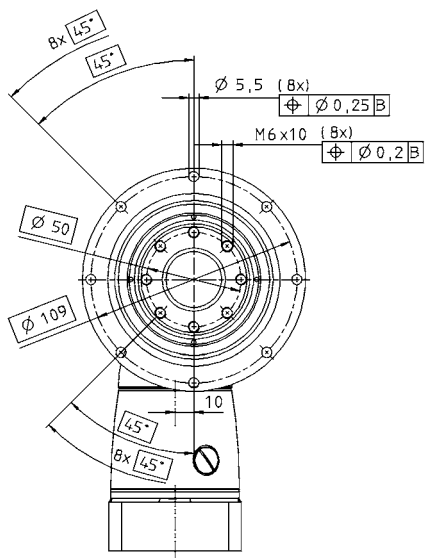

See technical data sheet for available clamping hub diameters (mass moment of inertia). Dimensions available on request.

Non-tolerated dimensions ± 1 mm

- 1) Check motor shaft fit.
- 2) Min./Max. permissible motor shaft length. Longer motor shafts are adaptable, please contact us.
- 3) The dimensions depend on the motor.
- 4) Smaller motor shaft diameter is compensated by a bushing with a minimum thickness of 1 mm.

Motor mounting according to operating manual

TK-TPK



TPK+ 010 MF 3-stage

		3-stage														
Ratio ^{a)}	<i>i</i>		64	84	100	125	140	175	200	250	280	350	400	500	700	1000
Max. acceleration torque (max. 1000 cycles per hour)	T_{2B}	Nm	120	120	130	130	130	130	130	130	130	130	80	100	130	100
		in.lb	1062	1062	1151	1151	1151	1151	1151	1151	1151	1151	708	885	1151	885
Nominal output torque (with n_m)	T_{2N}	Nm	85	85	90	90	90	90	90	90	75	90	60	75	90	60
		in.lb	752	752	797	797	797	797	797	797	664	797	531	664	797	531
Emergency stop torque (permitted 1000 times during the service life of the gearhead)	T_{2Not}	Nm	200	160	250	250	250	250	250	250	250	250	160	200	250	250
		in.lb	1770	1416	2213	2213	2213	2213	2213	2213	2213	2213	1416	1770	2213	2213
Nominal input speed (with T_{2N} and 20 °C ambient temperature) ^{b), c)}	n_{1N}	rpm	4400	4400	4400	4400	4400	4400	4400	4800	4400	4800	5500	5500	5500	5500
Max. continuous speed (with 20 % T_{2N} and 20 °C ambient temperature)	n_{1Nocym}	rpm	5000	5000	5000	5000	5000	5000	5000	5000	5000	5500	5500	5500	5500	5500
Max. input speed	n_{1Max}	rpm	6000	6000	6000	6000	6000	6000	6000	6000	6000	6000	6000	6000	6000	6000
Mean no load running torque (with $n_1=3000$ rpm and 20 °C gearhead temperature) ^{d)}	T_{012}	Nm	0.3	0.3	0.3	0.3	0.3	0.3	0.2	0.2	0.2	0.2	0.2	0.2	0.2	0.2
		in.lb	2.7	2.7	2.7	2.7	2.7	2.7	1.8	1.8	1.8	1.8	1.8	1.8	1.8	1.8
Max. torsional backlash	j_t	arcmin	Standard ≤ 5 / Reduced ≤ 3													
Torsional rigidity	C_{t21}	Nm/ arcmin	16	16	20	21	20	21	20	21	23	24	15	19	22	27
		in.lb/ arcmin	142	142	177	186	177	186	177	186	204	212	133	168	195	239
Tilting rigidity	C_{2K}	Nm/ arcmin	225													
		in.lb/ arcmin	1991													
Max. axial force ^{e)}	F_{2AMax}	N	2150													
		lb _f	484													
Max. tilting moment	M_{2KMax}	Nm	235													
		in.lb	2080													
Efficiency at full load	η	%	92													
Service life (For calculation, see the Chapter "Information")	L_h	h	> 20000													
Weight incl. standard adapter plate	<i>m</i>	kg	5,5													
		lb _m	12,2													
Operating noise (with $n_1=3000$ rpm no load)	L_{PA}	dB(A)	≤ 66													
Max. permitted housing temperature		°C	90													
		F	194													
Ambient temperature		°C	0 to +40													
		F	32 to 104													
Lubrication			Lubricated for life													
Paint			Blue RAL 5002													
Direction of rotation			Motor and gearhead opposite directions													
Protection class			IP 65													
Moment of inertia (relates to the drive) Clamping hub diameter [mm]	B	11	J_1	kgcm ²	0.09	0.07	0.08	0.07	0.06	0.06	0.06	0.06	0.06	0.06	0.06	0.06
				10 ⁻³ in.lb.s ²	0.08	0.06	0.07	0.06	0.05	0.05	0.05	0.05	0.05	0.05	0.05	0.05
	C	14	J_1	kgcm ²	0.20	0.18	0.19	0.19	0.18	0.18	0.17	0.17	0.17	0.17	0.17	0.17
				10 ⁻³ in.lb.s ²	0.18	0.16	0.17	0.17	0.16	0.16	0.15	0.15	0.15	0.15	0.15	0.15

Please contact us for information on the best configuration for S1 conditions of use (continuous operation).

- ^{a)} Other ratios available on request
- ^{b)} Higher speeds are possible if the nominal torque is reduced
- ^{c)} For higher ambient temperatures, please reduce input speed
- ^{d)} Idling torques decrease during operation
- ^{e)} Refers to center of the output shaft or flange

All technical data for front output side applies.
Please request information for rear output side versions.

View A

3-stage:

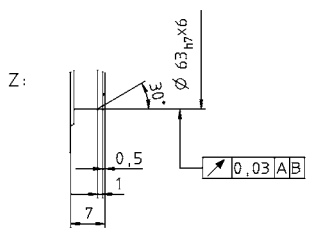
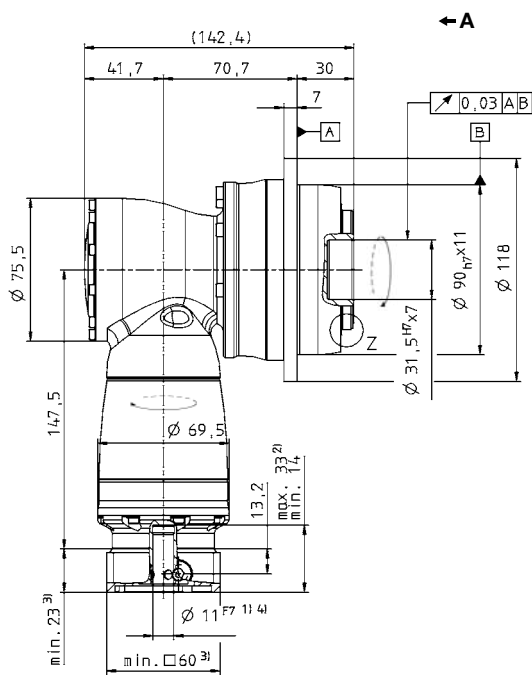
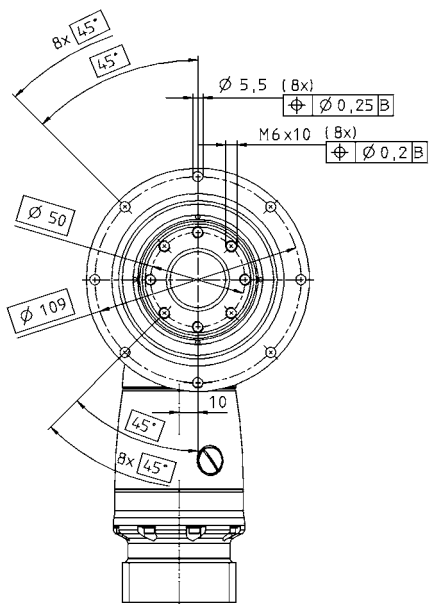

See technical data sheet for available clamping hub diameters (mass moment of inertia). Dimensions available on request.

Non-tolerated dimensions ± 1 mm

- 1) Check motor shaft fit.
- 2) Min./Max. permissible motor shaft length. Longer motor shafts are adaptable, please contact us.
- 3) The dimensions depend on the motor.
- 4) Smaller motor shaft diameter is compensated by a bushing with a minimum thickness of 1 mm.

Motor mounting according to operating manual



TPK+ 025 MF 2-stage

		2-stage													
Ratio ^{a)}	<i>i</i>		12	16	20	25	28	35	40	49	50	70	100		
Max. acceleration torque (max. 1000 cycles per hour)	T_{2B}	Nm	280	280	350	350	350	330	330	330	265	400	400		
		in.lb	2478	2478	3098	3098	3098	2921	1770	2921	2213	2921	2345		
Nominal output torque (with n_{1N})	T_{2V}	Nm	170	170	170	170	170	170	160	170	170	170	120		
		in.lb	1505	1505	1505	1505	1505	1505	1416	1505	1505	1505	1062		
Emergency stop torque (permitted 1000 times during the service life of the gearhead)	T_{2Not}	Nm	400	575	575	500	625	625	400	625	500	625	625		
		in.lb	3540	5089	5089	5089	5531	5531	3540	5531	4425	5531	5531		
Nominal input speed (with T_{2V} and 20 °C ambient temperature) ^{b), c)}	n_{1N}	rpm	2000	2400	2400	2700	2400	2500	2500	2500	2500	2500	2500		
Max. continuous speed (with 20 % T_{2V} and 20 °C ambient temperature)	n_{1Ncym}	rpm	3000	3400	3400	3800	3400	3200	3200	3200	3200	3200	3200		
Max. input speed	n_{1Max}	rpm	6000	6000	6000	6000	6000	6000	6000	6000	6000	6000	6000		
Mean no load running torque (with $n_1=3000$ rpm and 20 °C gearhead temperature) ^{d)}	T_{012}	Nm	2.5	2.1	2.0	1.8	2.0	1.8	2.0	2.2	2.0	2.0	2.0		
		in.lb	22.1	18.6	17.7	15.9	17.7	15.9	17.7	19.5	17.7	17.7	17.7		
Max. torsional backlash	j_t	arcmin	Standard ≤ 4 / Reduced ≤ 2												
Torsional rigidity	C_{t21}	Nm/ arcmin	40	42	53	55	59	60	44	60	55	60	56		
		in.lb/ arcmin	354	372	469	487	522	531	389	531	487	531	496		
Tilting rigidity	C_{2K}	Nm/ arcmin	550												
		in.lb/ arcmin	4868												
Max. axial force ^{e)}	F_{2AMax}	N	4150												
		lb _f	934												
Max. tilting moment	M_{2KMax}	Nm	413												
		in.lb	3655												
Efficiency at full load	η	%	94												
Service life (For calculation, see the Chapter "Information")	L_h	h	> 20000												
Weight incl. standard adapter plate	<i>m</i>	kg	9.0												
		lb _m	19.9												
Operating noise (with $n_1=3000$ rpm no load)	L_{PA}	dB(A)	≤ 68												
Max. permitted housing temperature		°C	+90												
		F	194												
Ambient temperature		°C	0 to +40												
		F	32 to 104												
Lubrication			Lubricated for life												
Paint			Blue RAL 5002												
Direction of rotation			Motor and gearhead opposite directions												
Protection class			IP 65												
Moment of inertia (relates to the drive) Clamping hub diameter [mm]	E	19	J_1	kgcm ²	1.43	1.18	1.16	1.04	1.14	0.94	0.89	0.95	0.89	0.89	0.89
				10 ⁻³ in.lb.s ²	1.27	1.04	1.02	0.92	1.01	0.83	0.79	0.84	0.79	0.79	0.78
	H	28	J_1	kgcm ²	2.85	2.59	2.57	2.45	2.56	2.40	2.31	2.37	2.30	2.30	2.30
				10 ⁻³ in.lb.s ²	2.52	2.29	2.27	2.17	2.26	2.08	2.04	2.10	2.04	2.04	2.04

Please contact us for information on the best configuration for S1 conditions of use (continuous operation).

- ^{a)} Other ratios up to $i=1000$ available on request
- ^{b)} Higher speeds are possible if the nominal torque is reduced
- ^{c)} For higher ambient temperatures, please reduce input speed
- ^{d)} Idling torques decrease during operation
- ^{e)} Refers to center of the output shaft or flange

All technical data for front output side applies.
Please request information for rear output side versions.

View A

2-stage:

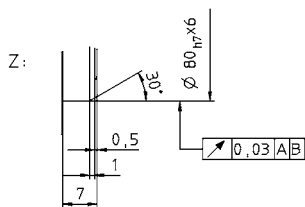
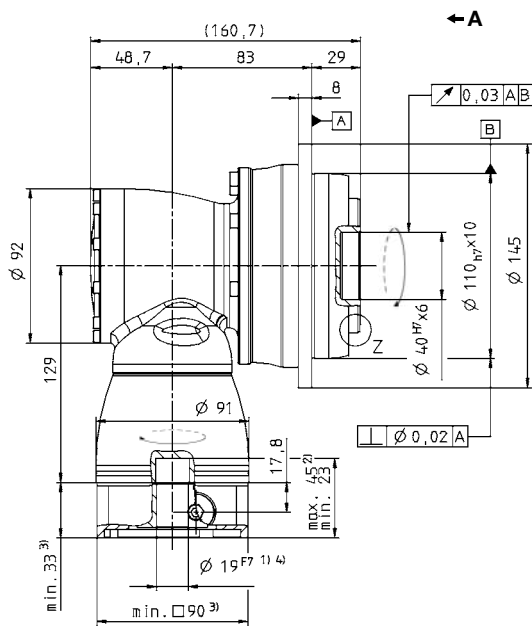
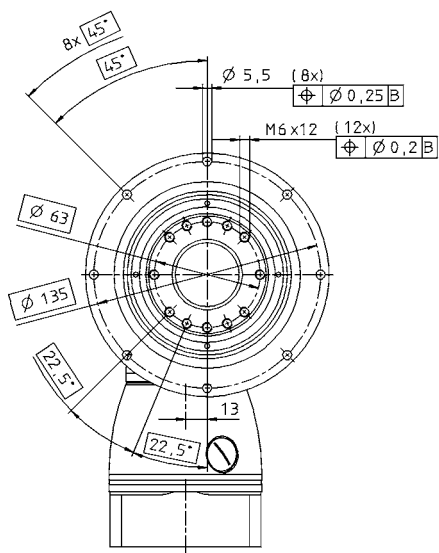

See technical data sheet for available clamping hub diameters (mass moment of inertia). Dimensions available on request.

Non-tolerated dimensions ± 1 mm

- 1) Check motor shaft fit.
- 2) Min./Max. permissible motor shaft length. Longer motor shafts are adaptable, please contact us.
- 3) The dimensions depend on the motor.
- 4) Smaller motor shaft diameter is compensated by a bushing with a minimum thickness of 1 mm.

Motor mounting according to operating manual

TK-
TPK-



TPK+ 025 MF 3-stage

		3-stage															
Ratio ^{a)}	<i>i</i>		64	84	100	125	140	175	200	250	280	350	400	500	700	1000	
Max. acceleration torque (max. 1000 cycles per hour)	T_{2B}	Nm	280	280	350	350	350	350	350	350	350	330	200	250	330	265	
		in.lb	2478	2478	3098	3098	3098	3098	3098	3098	3098	2921	1770	2213	2921	2345	
Nominal output torque (with n_m)	T_{2N}	Nm	200	170	200	200	200	200	200	200	210	200	160	200	200	120	
		in.lb	1770	1505	1770	1770	1770	1770	1770	1770	1859	1770	1416	1770	1770	1062	
Emergency stop torque (permitted 1000 times during the service life of the gearhead)	T_{2Not}	Nm	460	400	575	575	575	575	575	575	625	625	400	500	625	625	
		in.lb	4071	3540	5089	5089	5089	5089	5089	5089	5531	5531	3540	4425	5531	5531	
Nominal input speed (with T_{2N} and 20 °C ambient temperature) ^{b), c)}	n_{1N}	rpm	3500	3500	3500	3500	3500	3500	3500	3800	3500	3800	4500	4500	4500	4500	
Max. continuous speed (with 20 % T_{2N} and 20 °C ambient temperature)	n_{1Nocym}	rpm	4500	4500	4500	4500	4500	4500	4500	4500	4500	4500	4500	4500	4500	4500	
Max. input speed	n_{1Max}	rpm	6000	6000	6000	6000	6000	6000	6000	6000	6000	6000	6000	6000	6000	6000	
Mean no load running torque (with $n_1=3000$ rpm and 20 °C gearhead temperature) ^{d)}	T_{012}	Nm	0.4	0.3	0.3	0.3	0.3	0.3	0.2	0.2	0.2	0.2	0.2	0.2	0.2	0.2	
		in.lb	3.5	2.7	2.7	2.7	2.7	2.7	1.8	1.8	1.8	1.8	1.8	1.8	1.8	1.8	
Max. torsional backlash	j_t	arcmin	Standard ≤ 4 / Reduced ≤ 2														
Torsional rigidity	C_{t21}	Nm/ arcmin	42	40	53	55	53	55	53	55	59	60	44	55	60	56	
		in.lb/ arcmin	372	354	469	487	469	487	469	487	522	531	389	487	531	496	
Tilting rigidity	C_{2K}	Nm/ arcmin	550														
		in.lb/ arcmin	4868														
Max. axial force ^{e)}	F_{2AMax}	N	4150														
		lb _f	934														
Max. tilting moment	M_{2KMax}	Nm	413														
		in.lb	3655														
Efficiency at full load	η	%	92														
Service life (For calculation, see the Chapter "Information")	L_h	h	> 20000														
Weight incl. standard adapter plate	<i>m</i>	kg	9,8														
		lb _m	21,7														
Operating noise (with $n_1=3000$ rpm no load)	L_{PA}	dB(A)	≤ 68														
Max. permitted housing temperature		°C	90														
		F	194														
Ambient temperature		°C	0 to +40														
		F	32 to 104														
Lubrication			Lubricated for life														
Paint			Blue RAL 5002														
Direction of rotation			Motor and gearhead opposite directions														
Protection class			IP 65														
Moment of inertia (relates to the drive) Clamping hub diameter [mm]	C	14	J_1	kgcm ²	0.28	0.23	0.24	0.23	0.21	0.20	0.19	0.18	0.19	0.18	0.18	0.18	0.18
				10 ⁻³ in.lb.s ²	0.25	0.20	0.21	0.20	0.19	0.18	0.17	0.16	0.17	0.16	0.16	0.16	0.16
	E	19	J_1	kgcm ²	0.72	0.63	0.68	0.68	0.63	0.63	0.63	0.63	0.63	0.63	0.63	0.63	0.63
				10 ⁻³ in.lb.s ²	0.64	0.56	0.60	0.60	0.56	0.56	0.56	0.56	0.56	0.56	0.56	0.56	0.56

Please contact us for information on the best configuration for S1 conditions of use (continuous operation).

^{a)} Other ratios available on request

^{b)} Higher speeds are possible if the nominal torque is reduced

^{c)} For higher ambient temperatures, please reduce input speed

^{d)} Idling torques decrease during operation

^{e)} Refers to center of the output shaft or flange

All technical data for front output side applies.

Please request information for rear output side versions.

3-stage:

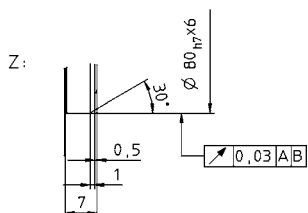
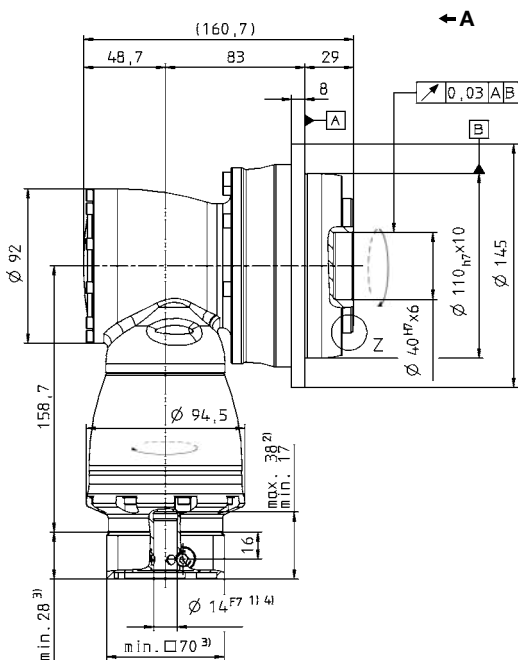
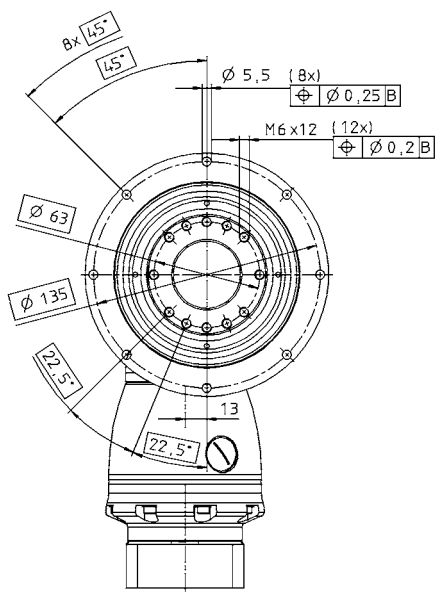

See technical data sheet for available clamping hub diameters (mass moment of inertia). Dimensions available on request.

Non-tolerated dimensions ± 1 mm

- 1) Check motor shaft fit.
- 2) Min./Max. permissible motor shaft length. Longer motor shafts are adaptable, please contact us.
- 3) The dimensions depend on the motor.
- 4) Smaller motor shaft diameter is compensated by a bushing with a minimum thickness of 1 mm.

Motor mounting according to operating manual



TPK+ 050 MF 2-stage

		2-stage													
Ratio ^{a)}	<i>i</i>		12	16	20	25	28	35	40	49	50	70	100		
Max. acceleration torque (max. 1000 cycles per hour)	T_{2B}	Nm	680	680	750	750	700	700	500	700	625	700	540		
		in.lb	6018	6018	6638	6638	6195	6416	4425	6195	5531	6195	4779		
Nominal output torque (with n_{1N})	T_{2N}	Nm	370	370	370	370	370	370	320	370	370	370	240		
		in.lb	3275	3275	3275	3275	3275	3275	2832	3275	3275	3275	2124		
Emergency stop torque (permitted 1000 times during the service life of the gearhead)	T_{2Not}	Nm	1000	1000	1250	1250	1250	1250	1000	1250	1250	1250	1250		
		in.lb	8850	8850	11063	11063	11063	11063	8850	11063	11063	11063	11063		
Nominal input speed (with T_{2N} and 20 °C ambient temperature) ^{b), c)}	n_{1N}	rpm	1900	2300	2300	2600	2300	2300	2300	2300	2300	2300	2300		
Max. continuous speed (with 20 % T_{2N} and 20 °C ambient temperature)	n_{1Nocym}	rpm	2700	3100	3100	3500	3100	3000	3000	3000	3000	3000	3000		
Max. input speed	n_{1Max}	rpm	4500	4500	4500	4500	4500	4500	4500	4500	4500	4500	4500		
Mean no load running torque (with $n_1=3000$ rpm and 20 °C gearhead temperature) ^{d)}	T_{012}	Nm	4.0	3.7	3.6	2.8	3.5	2.8	3.1	3.9	3.1	3.1	3.1		
		in.lb	35.4	32.7	31.9	24.8	31.0	24.8	27.4	34.5	27.4	27.4	27.4		
Max. torsional backlash	j_t	arcmin	Standard ≤ 4 / Reduced ≤ 2												
Torsional rigidity	C_{t21}	Nm/ arcmin	87	91	111	119	123	127	96	127	115	125	112		
		in.lb/ arcmin	770	805	982	1053	1089	1124	850	1124	1018	1106	991		
Tilting rigidity	C_{2K}	Nm/ arcmin	560												
		in.lb/ arcmin	4956												
Max. axial force ^{e)}	F_{2AMax}	N	6130												
		lb _f	1379												
Max. tilting moment	M_{2KMax}	Nm	1295												
		in.lb	11461												
Efficiency at full load	η	%	94												
Service life (For calculation, see the Chapter "Information")	L_h	h	> 20000												
Weight incl. standard adapter platee	<i>m</i>	kg	17.0												
		lb _m	38												
Operating noise (with $n_1=3000$ rpm no load)	L_{PA}	dB(A)	≤ 68												
Max. permitted housing temperature		°C	+90												
		F	194												
Ambient temperature		°C	0 to +40												
		F	32 to 104												
Lubrication			Lubricated for life												
Paint			Blue RAL 5002												
Direction of rotation			Motor and gearhead opposite directions												
Protection class			IP 65												
Moment of inertia (relates to the drive) Clamping hub diameter [mm]	H	28	J_1	kgcm ²	4.56	3.76	3.71	3.28	3.66	3.00	2.79	3.10	2.78	2.77	2.77
				10 ⁻³ in.lb.s ²	4.04	3.32	3.28	2.90	3.24	2.61	2.47	2.74	2.46	2.45	2.45
	K	38	J_1	kgcm ²	11.7	10.9	10.9	10.4	10.8	10.3	9.95	10.4	9.94	9.94	9.93
				10 ⁻³ in.lb.s ²	10.38	9.67	9.62	9.24	9.58	8.96	8.81	9.20	8.80	8.80	8.79

Please contact us for information on the best configuration for S1 conditions of use (continuous operation).

- ^{a)} Other ratios up to $i=1000$ available on request
- ^{b)} Higher speeds are possible if the nominal torque is reduced
- ^{c)} For higher ambient temperatures, please reduce input speed
- ^{d)} Idling torques decrease during operation
- ^{e)} Refers to center of the output shaft or flange

All technical data for front output side applies.
Please request information for rear output side versions.

View A

2-stage:

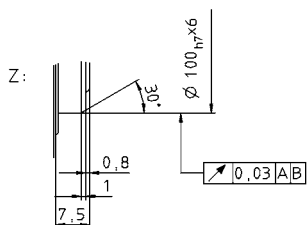
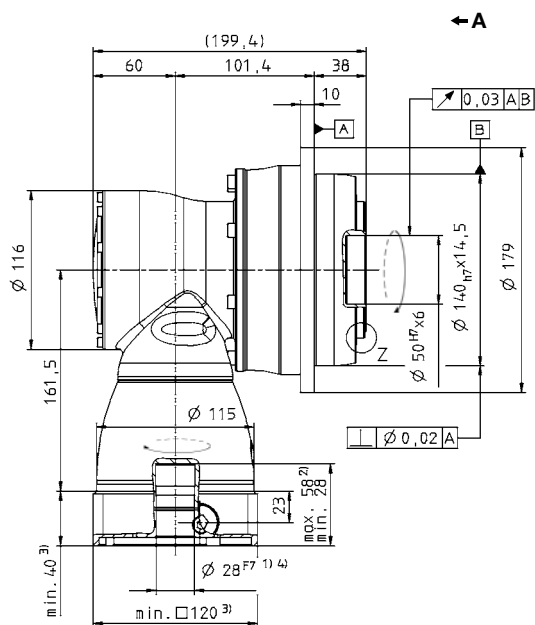
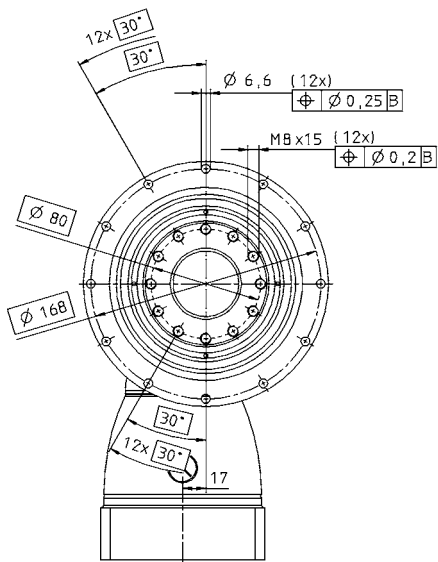

See technical data sheet for available clamping hub diameters (mass moment of inertia). Dimensions available on request.

Non-tolerated dimensions ± 1 mm

- 1) Check motor shaft fit.
- 2) Min./Max. permissible motor shaft length. Longer motor shafts are adaptable, please contact us.
- 3) The dimensions depend on the motor.
- 4) Smaller motor shaft diameter is compensated by a bushing with a minimum thickness of 1 mm.

Motor mounting according to operating manual



TPK+ 050 MF 3-stage

		3-stage															
Ratio ^{a)}	<i>i</i>		64	84	100	125	140	175	200	250	280	350	400	500	700	1000	
Max. acceleration torque (max. 1000 cycles per hour)	T_{2B}	Nm	680	680	750	750	750	750	750	750	700	700	500	625	700	540	
		in.lb	6018	6018	6638	6638	6638	6638	6638	6638	6195	6195	4425	5531	6195	4779	
Nominal output torque (with n_m)	T_{2N}	Nm	400	400	400	400	400	400	400	400	400	400	320	370	400	240	
		in.lb	3540	3540	3540	3540	3540	3540	3540	3540	3540	3540	2832	3275	3540	2124	
Emergency stop torque (permitted 1000 times during the service life of the gearhead)	T_{2Not}	Nm	1000	1000	1250	1250	1250	1250	1250	1250	1250	1250	1000	1250	1250	1250	
		in.lb	8850	8850	11063	11063	11063	11063	11063	11063	11063	11063	8850	11063	11063	11063	
Nominal input speed (with T_{2N} and 20 °C ambient temperature) ^{b), c)}	n_{1N}	rpm	3100	3100	3100	3100	3100	3100	3100	3500	3100	3500	4200	4200	4200	4200	
Max. continuous speed (with 20 % T_{2N} and 20 °C ambient temperature)	n_{1Nocym}	rpm	4000	4000	4000	4000	4000	4000	4000	4000	4000	4000	4200	4200	4200	4200	
Max. input speed	n_{1Max}	rpm	4500	4500	4500	4500	4500	4500	4500	4500	4500	4500	4500	4500	4500	4500	
Mean no load running torque (with $n_1=3000$ rpm and 20 °C gearhead temperature) ^{d)}	T_{012}	Nm	0.7	0.4	0.6	0.5	0.5	0.4	0.3	0.3	0.3	0.3	0.3	0.3	0.3	0.3	
		in.lb	6.2	3.5	5.3	4.4	4.4	3.5	2.7	2.7	2.7	2.7	2.7	2.7	2.7	2.7	
Max. torsional backlash	j_t	arcmin	Standard ≤ 4 / Reduced ≤ 2														
Torsional rigidity	C_{t21}	Nm/ arcmin	91	87	111	119	111	119	111	119	123	127	95	115	125	112	
		in.lb/ arcmin	805	770	982	1053	982	1053	982	1053	1089	1124	841	1018	1106	991	
Tilting rigidity	C_{2K}	Nm/ arcmin	560														
		in.lb/ arcmin	4956														
Max. axial force ^{e)}	F_{2AMax}	N	6130														
		lb _f	1379														
Max. tilting moment	M_{2KMax}	Nm	1295														
		in.lb	11461														
Efficiency at full load	η	%	92														
Service life (For calculation, see the Chapter "Information")	L_h	h	> 20000														
Weight incl. standard adapter plate	<i>m</i>	kg	18,7														
		lb _m	41,3														
Operating noise (with $n_1=3000$ rpm no load)	L_{PA}	dB(A)	< 68														
Max. permitted housing temperature		°C	90														
		F	194														
Ambient temperature		°C	0 to +40														
		F	32 to 104														
Lubrication			Lubricated for life														
Paint			Blue RAL 5002														
Direction of rotation			Motor and gearhead opposite directions														
Protection class			IP 65														
Moment of inertia (relates to the drive) Clamping hub diameter [mm]	E	19	J_1	kgcm ²	1.01	0.76	0.88	0.85	0.76	0.75	0.70	0.69	0.70	0.69	0.69	0.69	0.69
				10 ⁻³ in.lb.in. ²	0.89	0.67	0.78	0.75	0.67	0.66	0.62	0.61	0.62	0.61	0.61	0.61	0.61
	G	24	J_1	kgcm ²	2.57	2.32	2.44	2.42	2.32	2.31	2.26	2.25	2.26	2.25	2.25	2.25	2.25
				10 ⁻³ in.lb.in. ²	2.27	2.05	2.16	2.14	2.05	2.04	2.00	1.99	2.00	1.99	1.99	1.99	1.99

Please contact us for information on the best configuration for S1 conditions of use (continuous operation).

^{a)} Other ratios available on request

^{b)} Higher speeds are possible if the nominal torque is reduced

^{c)} For higher ambient temperatures, please reduce input speed

^{d)} Idling torques decrease during operation

^{e)} Refers to center of the output shaft or flange

All technical data for front output side applies.

Please request information for rear output side versions.

View A

3-stage:

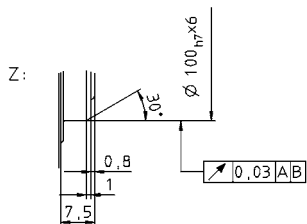
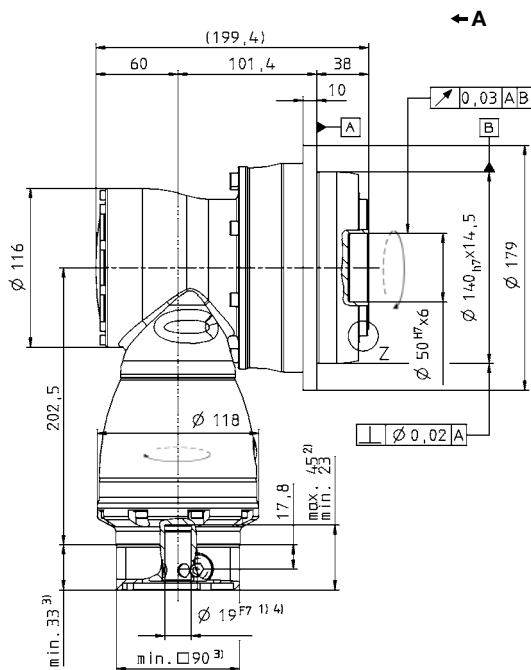
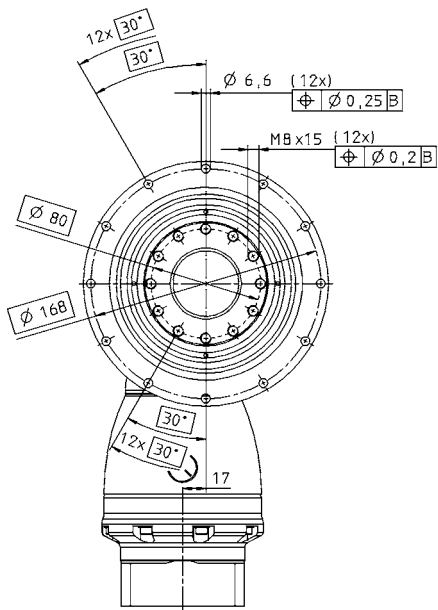

See technical data sheet for available clamping hub diameters (mass moment of inertia). Dimensions available on request.

Non-tolerated dimensions ± 1 mm

- 1) Check motor shaft fit.
- 2) Min./Max. permissible motor shaft length. Longer motor shafts are adaptable, please contact us.
- 3) The dimensions depend on the motor.
- 4) Smaller motor shaft diameter is compensated by a bushing with a minimum thickness of 1 mm.

Motor mounting according to operating manual



TPK+ 050 MA HIGH TORQUE® 3/4-stage

		3-stage								4-stage										
Ratio ^{a)}	<i>i</i>	66	88	110	137,5	154	220	385	330	462	577,5	770	1078	1540	2695	3850	5500			
Max. acceleration torque (max. 1000 cycles per hour)	T_{2B}	Nm	950	950	950	950	950	950	950	950	950	950	950	950	950	950	950	950		
		in.lb	8408	8408	8408	8408	8408	8408	8408	8408	8408	8408	8408	8408	8408	8408	8408	8408	8408	
Nominal output torque (with n_{1N})	T_{2N}	Nm	675	675	675	675	675	675	675	675	675	675	675	675	675	675	675	675		
		in.lb	5.974	5.974	5.974	5.974	5.974	5.974	5.974	5.974	5.974	5.974	5.974	5.974	5.974	5.974	5.974	5.974	5.974	
Emergency stop torque (permitted 1000 times during the service life of the gearhead)	T_{2Not}	Nm	2100	2375	2375	2375	2375	2200	2375	2100	2375	2375	2375	2375	2375	2375	2375	2375		
		in.lb	18585	21019	21019	21019	21019	19470	21019	18585	21019	21019	21019	21019	21019	21019	21019	21019	21019	
Nominal input speed (with T_{2N} and 20 °C ambient temperature) ^{b), c)}	n_{1N}	rpm	2200	2400	2700	2700	2700	2700	2700	3400	3400	3400	3400	3400	4400	4400	4400			
Max. continuous speed (with 20 % T_{2N} and 20 °C ambient temperature)	n_{1Nocym}	rpm	2800	3300	3800	3800	3300	3300	3300	4300	4300	4300	4300	4300	4400	4400	4400			
Max. input speed	n_{1Max}	rpm	6000	6000	6000	6000	6000	6000	6000	6000	6000	6000	6000	6000	6000	6000	6000			
Mean no load running torque (with $n_1=3000$ rpm and 20 °C gearhead temperature) ^{d)}	T_{012}	Nm	2.9	2.4	2.0	2.1	2.4	2.1	2.0	0.4	0.5	0.3	0.3	0.3	0.2	0.1	0.1	0.1		
		in.lb	25.7	21.0	18.1	18.4	21.1	18.3	17.7	3.4	4.1	3.0	2.7	2.4	1.3	1.1	1.1	1.0		
Max. torsional backlash	j_t	arcmin	≤ 1,3																	
Torsional rigidity	C_{t21}	Nm/ arcmin	202	203	205	210	205	205	215	202	214	208	209	214	214	215	215	217		
		in.lb/ arcmin	1785	1798	1810	1857	1810	1810	1900	1785	1891	1840	1849	1896	1896	1900	1900	1924		
Tilting rigidity	C_{2K}	Nm/ arcmin	560																	
		in.lb/ arcmin	4956																	
Max. axial force ^{e)}	F_{2AMax}	N	6130																	
		lb _f	1379																	
Max. tilting moment	M_{2KMax}	Nm	1335																	
		in.lb	11815																	
Efficiency at full load	η	%	92								90									
Service life (For calculation, see the Chapter "Information")	L_h	h	> 20000																	
Weight incl. standard adapter plate	<i>m</i>	kg	-																	
		lb _m	-																	
Operating noise (with $n_1=3000$ rpm no load)	L_{PA}	dB(A)	≤ 68																	
Max. permitted housing temperature		°C	+90																	
		F	+194																	
Ambient temperature		°C	0 to +40																	
		F	32 to 104																	
Lubrication			Lubricated for life																	
Paint			Blue RAL 5002																	
Direction of rotation			Motor and gearhead opposite directions																	
Protection class			IP 65																	
Moment of inertia (relates to the drive) Clamping hub diameter [mm]	E	19	J_1	kgcm ²	-	-	-	-	-	-	0,24	0,29	0,20	0,20	0,20	0,19	0,18	0,18	0,18	
				10 ⁻³ in.lb.in. ²	-	-	-	-	-	-	-	0,21	0,26	0,18	0,18	0,18	0,16	0,16	0,16	0,16
	G	24	J_1	kgcm ²	1,65	1,30	1,13	1,11	0,99	0,91	0,90	0,68	0,73	0,63	0,63	0,63	0,63	0,63	0,63	0,63
				10 ⁻³ in.lb.in. ²	1,46	1,15	1,00	0,98	0,87	0,81	0,80	0,61	0,65	0,56	0,56	0,56	0,56	0,55	0,55	0,55
H	28	J_1	kgcm ²	3,07	2,71	2,54	2,53	2,40	2,33	2,32	-	-	-	-	-	-	-	-	-	
			10 ⁻³ in.lb.in. ²	2,72	2,40	2,25	2,24	2,13	2,06	2,05	-	-	-	-	-	-	-	-	-	-

Please contact us for information on the best configuration for S1 conditions of use (continuous operation).

^{a)} Other ratios available on request

^{b)} Higher speeds are possible if the nominal torque is reduced

^{c)} For higher ambient temperatures, please reduce input speed

^{d)} Idling torques decrease during operation

^{e)} Refers to center of the output shaft or flange

All technical data for front output side applies.

Please request information for rear output side versions.

View A

3-stage:

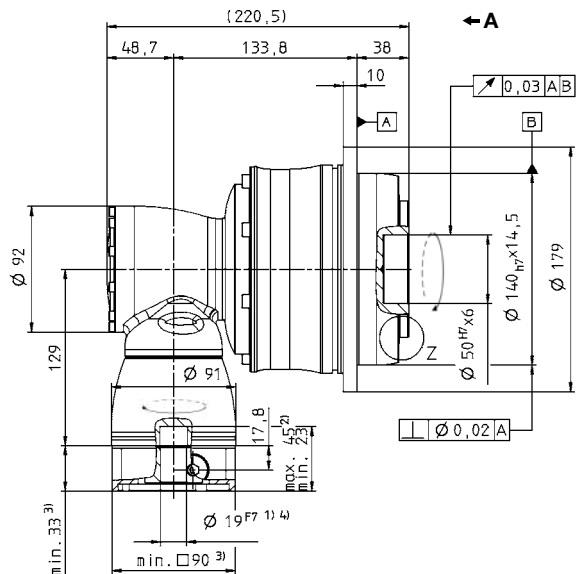
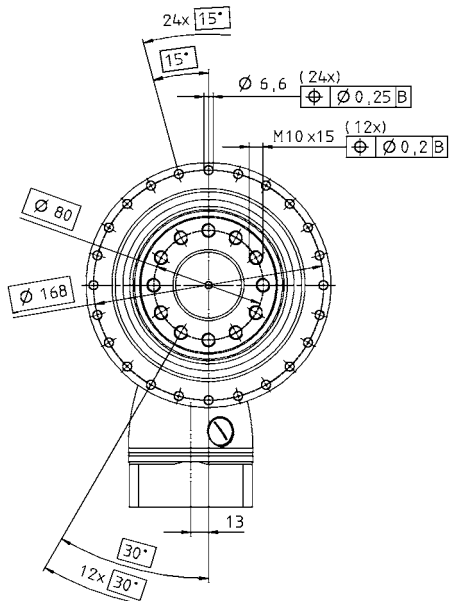

4-stage:

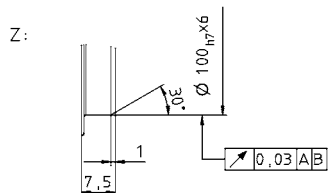
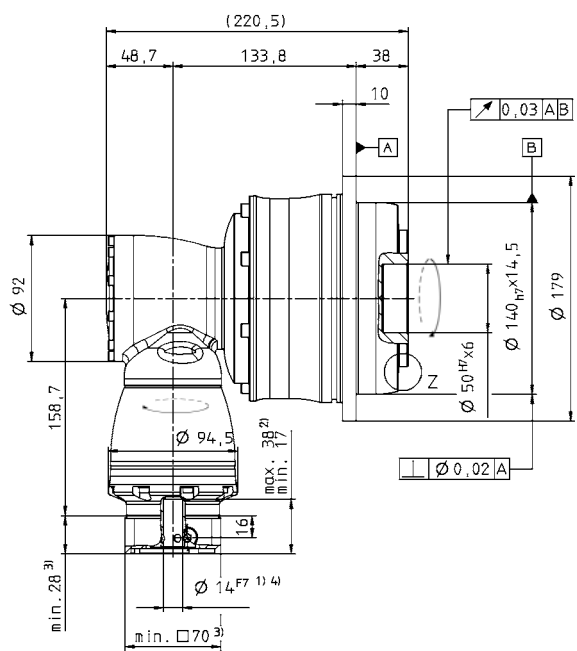
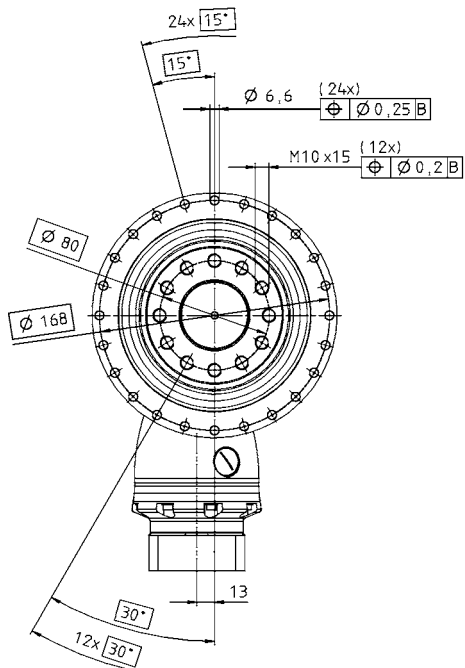

See technical data sheet for available clamping hub diameters (mass moment of inertia). Dimensions available on request.

Non-tolerated dimensions ± 1 mm

- 1) Check motor shaft fit.
- 2) Min./Max. permissible motor shaft length. Longer motor shafts are adaptable, please contact us.
- 3) The dimensions depend on the motor.
- 4) Smaller motor shaft diameter is compensated by a bushing with a minimum thickness of 1 mm.

Motor mounting according to operating manual

TK-
TPK-



TPK+ 110 MF 2-stage

		2-stage												
Ratio ^{a)}	<i>i</i>		12	16	20	25	28	35	40	49	50	70	100	
Max. acceleration torque (max. 1000 cycles per hour)	T_{2B}	Nm	1200	1200	1500	1500	1600	1600	840	1600	1050	1470	1400	
		in.lb	10620	10620	13275	13275	14160	14160	7434	14160	9293	13010	12390	
Nominal output torque (with n_{1N})	T_{2N}	Nm	700	700	750	750	750	750	640	750	750	750	750	
		in.lb	6195	6195	6638	6638	6638	6638	5664	6638	6638	6638	6638	
Emergency stop torque (permitted 1000 times during the service life of the gearhead)	T_{2Not}	Nm	1600	2000	2500	2500	2750	2750	1600	2750	2000	2750	2750	
		in.lb	14160	17700	22125	22125	24338	24338	14160	24338	17700	24338	24338	
Nominal input speed (with T_{2N} and 20 °C ambient temperature) ^{b), c)}	n_{1N}	rpm	1600	1900	1900	2100	1900	2100	2100	2100	2100	2100	2100	
Max. continuous speed (with 20 % T_{2N} and 20 °C ambient temperature)	n_{1Ncym}	rpm	2300	2600	2600	2800	2600	3000	3000	3000	3000	3000	3000	
Max. input speed	n_{1Max}	rpm	4500	4500	4500	4500	4500	4500	4500	4500	4500	4500	4500	
Mean no load running torque (with $n_1=3000$ rpm and 20 °C gearhead temperature) ^{d)}	T_{012}	Nm	9.0	6.5	6.5	5.5	6.0	6.0	6.0	8.0	6.0	6.0	6.0	
		in.lb	79.7	57.5	57.5	48.7	53.1	53.1	53.1	70.8	53.1	53.1	53.1	
Max. torsional backlash	j_t	arcmin	Standard ≤ 4 / Reduced ≤ 2											
Torsional rigidity	C_{t21}	Nm/ arcmin	253	269	336	346	400	407	274	410	341	404	389	
		in.lb/ arcmin	2239	2381	2974	3062	3540	3602	2425	3629	3018	3575	3443	
Tilting rigidity	C_{2K}	Nm/ arcmin	1452											
		in.lb/ arcmin	12850											
Max. axial force ^{e)}	F_{2AMax}	N	10050											
		lb _f	2261											
Max. tilting moment	M_{2KMax}	Nm	3064											
		in.lb	27116											
Efficiency at full load	η	%	94											
Service life (For calculation, see the Chapter "Information")	L_h	h	> 20000											
Weight incl. standard adapter plate	<i>m</i>	kg	41.0											
		lb _m	91											
Operating noise (with $n_1=3000$ rpm no load)	L_{PA}	dB(A)	≤ 70											
Max. permitted housing temperature		°C	+90											
		F	194											
Ambient temperature		°C	0 to +40											
		F	32 to 104											
Lubrication			Lubricated for life											
Paint			Blue RAL 5002											
Direction of rotation			Motor and gearhead opposite directions											
Protection class			IP 65											
Moment of inertia (relates to the drive) Clamping hub diameter [mm]	K	38	J_1	kgcm ²	24.3	19.0	18.7	16.1	18.5	15.7	12.8	17.5	12.7	12.7
				10 ⁻³ in.lb.s ²	21.5	16.8	16.6	14.2	16.4	12.3	11.3	15.5	11.3	11.2

Please contact us for information on the best configuration for S1 conditions of use (continuous operation).

^{a)} Other ratios up to $i=1000$ available on request

^{b)} Higher speeds are possible if the nominal torque is reduced

^{c)} For higher ambient temperatures, please reduce input speed

^{d)} Idling torques decrease during operation

^{e)} Refers to center of the output shaft or flange

All technical data for front output side applies.

Please request information for rear output side versions.

View A

2-stage:

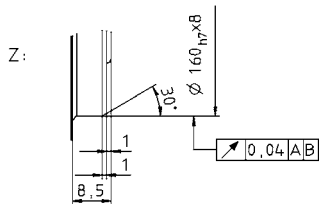
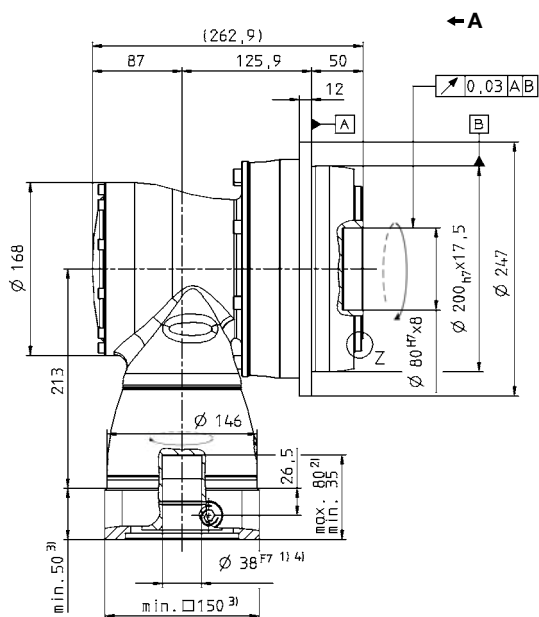
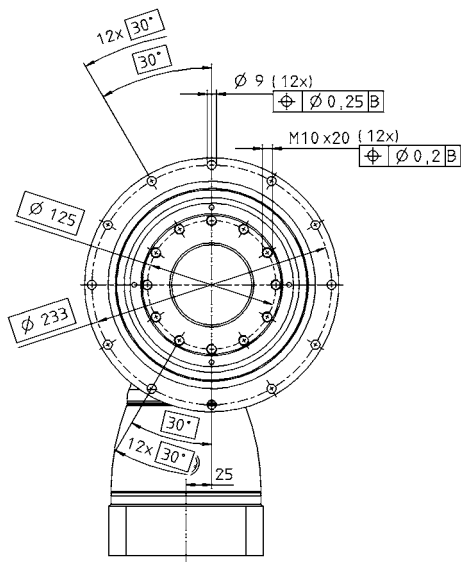

See technical data sheet for available clamping hub diameters (mass moment of inertia). Dimensions available on request.

Non-tolerated dimensions ± 1 mm

- 1) Check motor shaft fit.
- 2) Min./Max. permissible motor shaft length. Longer motor shafts are adaptable, please contact us.
- 3) The dimensions depend on the motor.
- 4) Smaller motor shaft diameter is compensated by a bushing with a minimum thickness of 1 mm.

Motor mounting according to operating manual

TK-
TPK-



TPK+ 110 MF 3-stage

		3-stage																
Ratio ^{a)}	<i>i</i>		64	84	100	125	140	175	200	250	280	350	400	500	700	1000		
Max. acceleration torque (max. 1000 cycles per hour)	T_{2B}	Nm	1200	1200	1500	1500	1500	1500	1500	1500	1600	1600	840	1050	1470	1400		
		in.lb	10620	10620	13275	13275	13275	13275	13275	13275	14160	14160	7434	9293	13010	12390		
Nominal output torque (with n_m)	T_{2N}	Nm	700	700	950	950	950	950	950	950	1120	1250	640	750	1120	800		
		in.lb	6195	6195	8408	8408	8408	8408	8408	8408	9912	11063	5664	6638	9912	7080		
Emergency stop torque (permitted 1000 times during the service life of the gearhead)	T_{2Not}	Nm	1600	1600	2500	2500	2500	2500	2500	2500	2750	2750	1600	2000	2750	2750		
		in.lb	14160	14160	22125	22125	22125	22125	22125	22125	24338	24338	14160	17700	24338	24338		
Nominal input speed (with T_{2N} and 20 °C ambient temperature) ^{b), c)}	n_{1N}	rpm	2900	2900	2900	2900	2900	2900	2900	3200	2900	3200	3900	3900	3900	3900		
Max. continuous speed (with 20 % T_{2N} and 20 °C ambient temperature)	n_{1Nocym}	rpm	4000	4000	4000	4000	4000	4000	4000	4000	4000	4000	4200	4200	4200	4200		
Max. input speed	n_{1Max}	rpm	4500	4500	4500	4500	4500	4500	4500	4500	4500	4500	4500	4500	4500	4500		
Mean no load running torque (with $n_1=3000$ rpm and 20 °C gearhead temperature) ^{d)}	T_{012}	Nm	1	0.5	0.8	0.6	0.6	0.5	0.5	0.4	0.5	0.4	0.4	0.4	0.4	0.4		
		in.lb	8.9	4.4	7.1	5.3	5.3	4.4	4.4	3.5	4.4	3.5	3.5	3.5	3.5	3.5		
Max. torsional backlash	j_t	arcmin	Standard ≤ 4 / Reduced ≤ 2															
Torsional rigidity	C_{t21}	Nm/ arcmin	269	252	336	346	336	346	336	346	400	407	274	341	404	389		
		in.lb/ arcmin	2381	2230	2974	3062	2974	3062	2974	3062	3540	3602	2425	3018	3575	3443		
Tilting rigidity	C_{2K}	Nm/ arcmin	1452															
		in.lb/ arcmin	12850															
Max. axial force ^{e)}	F_{2AMax}	N	10050															
		lb _f	2261															
Max. tilting moment	M_{2KMax}	Nm	3064															
		in.lb	27116															
Efficiency at full load	η	%	92															
Service life (For calculation, see the Chapter "Information")	L_h	h	> 20000															
Weight incl. standard adapter plate	<i>m</i>	kg	45,4															
		lb _m	100,3															
Operating noise (with $n_1=3000$ rpm no load)	L_{PA}	dB(A)	< 70															
Max. permitted housing temperature		°C	90															
		F	194															
Ambient temperature		°C	0 to +40															
		F	32 to 104															
Lubrication			Lubricated for life															
Paint			Blue RAL 5002															
Direction of rotation			Motor and gearhead opposite directions															
Protection class			IP 65															
Moment of inertia (relates to the drive) Clamping hub diameter [mm]	G	24	J_1	kgcm ²	3.97	2.82	3.36	3.22	2.82	2.75	2.50	2.47	2.50	2.44	2.42	2.42	2.42	
				10 ⁻³ in.lb.s ²	3.51	2.50	2.97	2.85	2.50	2.43	2.21	2.19	2.21	2.16	2.14	2.14	2.14	2.14
	K	38	J_1	kgcm ²	10.90	9.74	10.30	10.10	9.74	9.66	9.41	9.38	9.41	9.38	9.33	9.33	9.33	9.33
				10 ⁻³ in.lb.s ²	9.65	8.62	9.12	8.94	8.62	8.55	8.33	8.30	8.33	8.30	8.26	8.26	8.26	8.26

Please contact us for information on the best configuration for S1 conditions of use (continuous operation).

- ^{a)} Other ratios available on request
- ^{b)} Higher speeds are possible if the nominal torque is reduced
- ^{c)} For higher ambient temperatures, please reduce input speed
- ^{d)} Idling torques decrease during operation
- ^{e)} Refers to center of the output shaft or flange

All technical data for front output side applies.
Please request information for rear output side versions.

View A

3-stage:

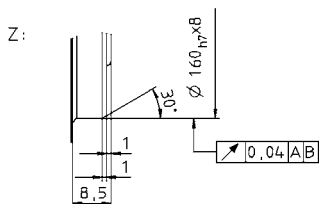
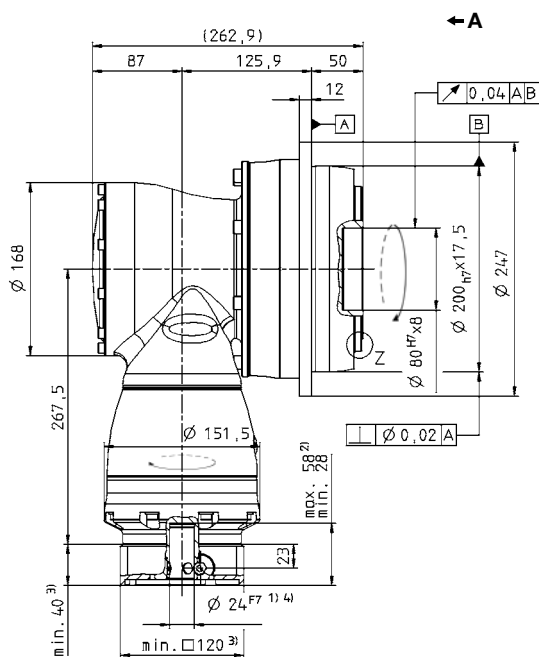
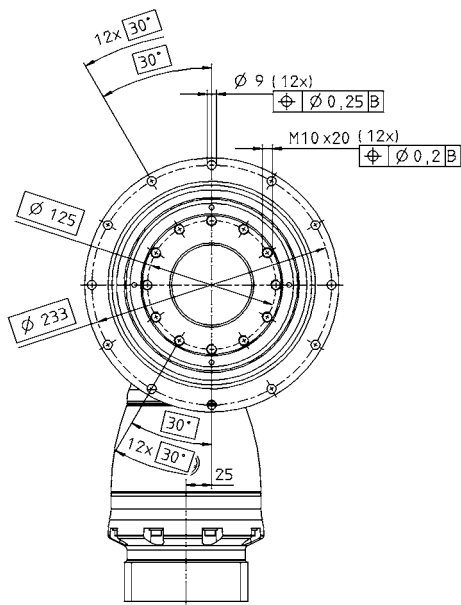

See technical data sheet for available clamping hub diameters (mass moment of inertia). Dimensions available on request.

Non-tolerated dimensions ±1 mm

- 1) Check motor shaft fit.
- 2) Min./Max. permissible motor shaft length. Longer motor shafts are adaptable, please contact us.
- 3) The dimensions depend on the motor.
- 4) Smaller motor shaft diameter is compensated by a bushing with a minimum thickness of 1 mm.

Motor mounting according to operating manual



TPK+ 110 MA HIGH TORQUE® 3/4-stage

		3-stage								4-stage								
Ratio ^{a)}	<i>i</i>	66	88	110	137,5	154	220	385	330	462	577,5	770	1078	1540	2695	3850	5500	
Max. acceleration torque (max. 1000 cycles per hour)	T_{2B}	Nm	3100	3100	3100	3100	3100	2750	3100	3100	3100	3100	3100	3100	3100	3100	3100	2000
		in.lb	27435	27435	27435	27435	27435	24338	27435	27435	27435	27435	27435	27435	27435	27435	27435	17700
Nominal output torque (with n_{1N})	T_{2N}	Nm	1650	1650	1650	1650	1650	1650	1650	1650	1650	1650	1650	1650	1650	1650	1650	1400
		in.lb	14603	14603	14603	14603	14603	14603	14603	14603	14603	14603	14603	14603	14603	14603	14603	12390
Emergency stop torque (permitted 1000 times during the service life of the gearhead)	T_{2Not}	Nm	4800	5700	5700	6500	5600	5500	6500	4800	6500	6000	6500	6500	6500	6500	6500	6500
		in.lb	42480	50445	50445	57525	49560	48675	57525	42480	57525	53100	57525	57525	57525	57525	57525	57525
Nominal input speed (with T_{2N} and 20 °C ambient temperature) ^{b), c)}	n_{1N}	rpm	2100	2300	2600	2600	2400	2400	2400	3000	3000	3000	3000	3000	3000	4100	4100	
Max. continuous speed (with 20 % T_{2N} and 20 °C ambient temperature)	n_{1Nocm}	rpm	2800	3200	3600	3600	3200	3200	3200	3800	3800	3800	3800	3800	3800	4100	4100	
Max. input speed	n_{1Max}	rpm	4500	4500	4500	4500	4500	4500	4500	4500	4500	4500	4500	4500	4500	4500	4500	
Mean no load running torque (with $n_1=3000$ rpm and 20 °C gearhead temperature) ^{d)}	T_{012}	Nm	6.0	4.6	3.6	3.4	4.4	3.5	3.3	0.9	1.0	0.7	0.6	0.6	0.3	0.3	0.2	0.2
		in.lb	53.1	40.7	31.9	30.1	38.9	31.0	29.2	8.0	8.9	6.2	5.3	5.3	2.7	2.7	1.8	1.8
Max. torsional backlash	j_t	arcmin	≤ 1,3															
Torsional rigidity	C_{t21}	Nm/ arcmin	634	642	654	675	654	648	687	634	682	662	667	685	685	689	687	658
		in.lb/ arcmin	5614	5681	5789	5976	5789	5739	6083	5614	6037	5855	5902	6062	6062	6101	6083	5822
Tilting rigidity	C_{2K}	Nm/ arcmin	1452															
		in.lb/ arcmin	12850															
Max. axial force ^{e)}	F_{2AMax}	N	10050															
		lb _f	2261															
Max. tilting moment	M_{2KMax}	Nm	3280															
		in.lb	29028															
Efficiency at full load	η	%	92								90							
Service life (For calculation, see the Chapter "Information")	L_h	h	> 20000															
Weight incl. standard adapter plate	<i>m</i>	kg	-															
		lb _m	-															
Operating noise (with $n_1=3000$ rpm no load)	L_{PA}	dB(A)	≤ 70															
Max. permitted housing temperature		°C	+90															
		F	+194															
Ambient temperature		°C	0 to +40															
		F	32 to 104															
Lubrication			Lubricated for life															
Paint			Blue RAL 5002															
Direction of rotation			Motor and gearhead opposite directions															
Protection class			IP 65															
Moment of inertia (relates to the drive) Clamping hub diameter [mm]	E	19	J_1	kgcm ²	-	-	-	-	-	-	0.89	1.06	0.76	0.76	0.76	0.69	0.68	0.68
				10 ⁻³ in.lb.s ²	-	-	-	-	-	-	-	-	0.79	0.94	0.68	0.67	0.67	0.61
	G	24	J_1	kgcm ²	-	-	-	-	-	-	2.46	2.63	2.33	2.32	2.32	2.26	2.25	2.25
				10 ⁻³ in.lb.s ²	-	-	-	-	-	-	-	-	2.17	2.33	2.06	2.06	2.05	2.00
	H	28	J_1	kgcm ²	5.48	4.27	3.64	3.58	3.14	2.87	2.84	-	-	-	-	-	-	-
				10 ⁻³ in.lb.s ²	4.85	3.78	3.22	3.17	2.78	2.54	2.51	-	-	-	-	-	-	-
	K	38	J_1	kgcm ²	12.72	11.52	10.89	10.83	10.39	10.12	10.09	-	-	-	-	-	-	-
				10 ⁻³ in.lb.s ²	11.26	10.19	9.64	9.58	9.19	8.95	8.93	-	-	-	-	-	-	-

Please contact us for information on the best configuration for S1 conditions of use (continuous operation).

^{a)} Other ratios available on request

^{b)} Higher speeds are possible if the nominal torque is reduced

^{c)} For higher ambient temperatures, please reduce input speed

^{d)} Idling torques decrease during operation

^{e)} Refers to center of the output shaft or flange

All technical data for front output side applies.

Please request information for rear output side versions.

View A

3-stage:

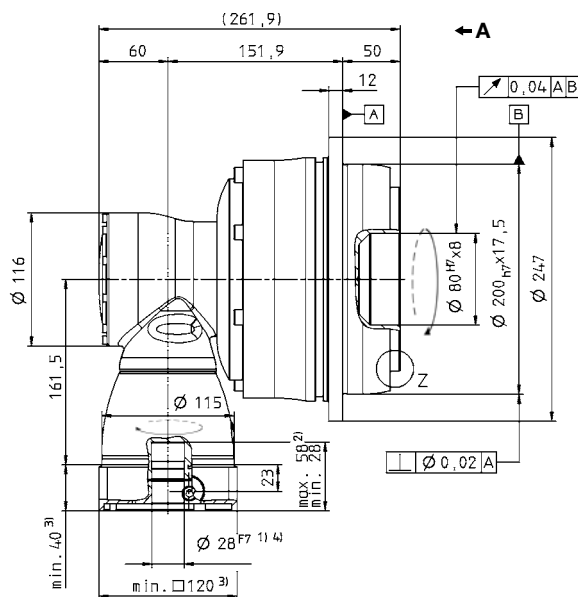
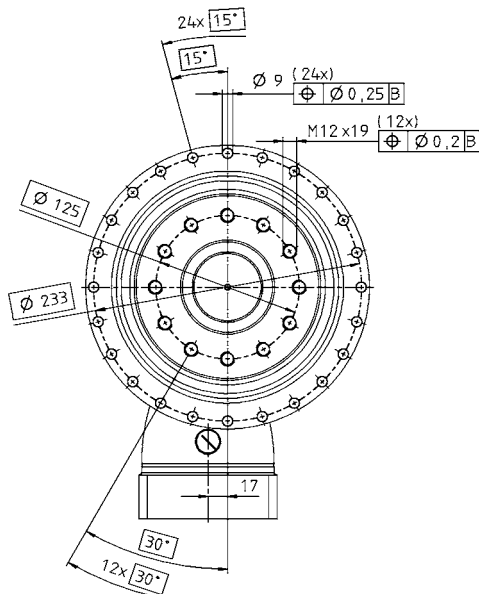

4-stage:

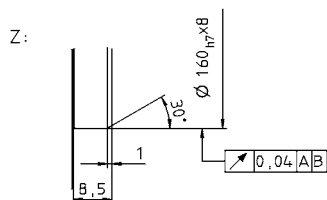
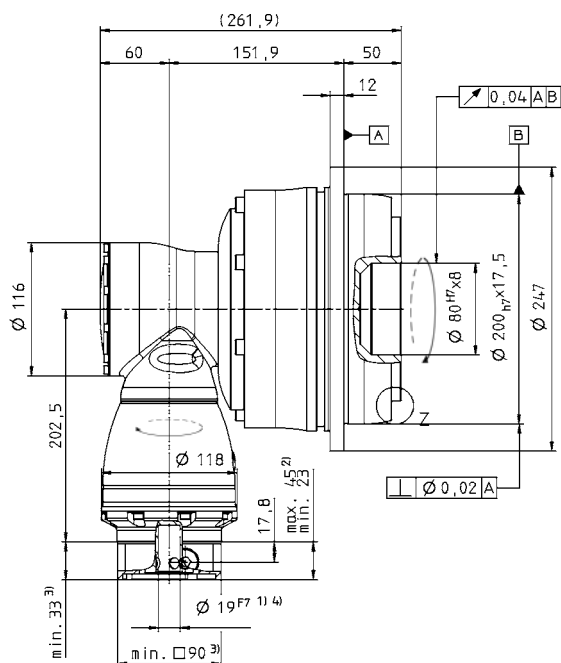
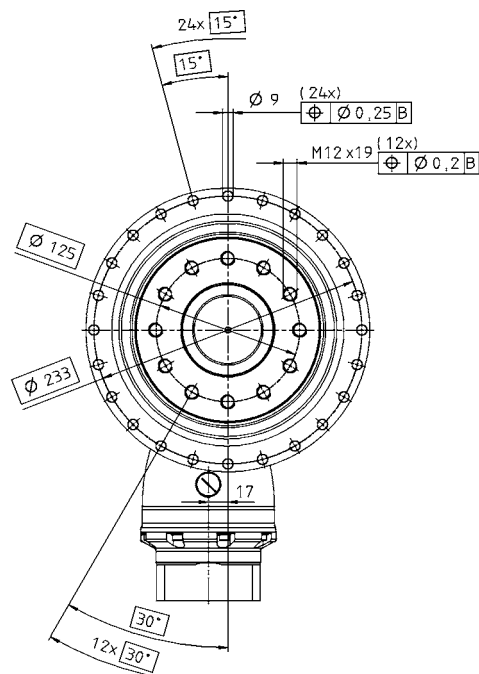

See technical data sheet for available clamping hub diameters (mass moment of inertia). Dimensions available on request.

Non-tolerated dimensions ± 1 mm

- 1) Check motor shaft fit.
- 2) Min./Max. permissible motor shaft length. Longer motor shafts are adaptable, please contact us.
- 3) The dimensions depend on the motor.
- 4) Smaller motor shaft diameter is compensated by a bushing with a minimum thickness of 1 mm.

Motor mounting according to operating manual



TPK+ 300 MF 2-stage

		2-stage										
Ratio ^{a)}	<i>i</i>		15	20	25	35	49	50	70	100		
Max. acceleration torque (max. 1000 cycles per hour)	T_{2B}	Nm	3200	3200	3200	3300	3300	2350	3300	2800		
		in.lb	28320	28320	28320	29205	29205	20798	29205	24780		
Nominal output torque (with n_m)	T_{2N}	Nm	2000	2000	2000	1800	1800	1800	1800	1600		
		in.lb	17.700	17.700	17.700	15.930	15.930	15.930	15.930	14.160		
Emergency stop torque (permitted 1000 times during the service life of the gearhead)	T_{2Not}	Nm	4500	5250	5250	7350	6800	4500	6300	8750		
		in.lb	39825	46463	46463	65048	60180	39825	55755	77438		
Nominal input speed (with T_{2N} and 20 °C ambient temperature) ^{b), c)}	n_{1N}	rpm	1500	1700	1900	1900	1700	1700	1700	1700		
Max. continuous speed (with 20 % T_{2N} and 20 °C ambient temperature)	n_{1Ncym}	rpm	1900	2300	2700	2700	2400	2400	2400	2400		
Max. input speed	n_{1Max}	rpm	4000	4000	4000	4000	4000	4000	4000	4000		
Mean no load running torque (with $n_1=3000$ rpm and 20 °C gearhead temperature) ^{d)}	T_{012}	Nm	18.5	15.0	13.0	12.0	12.0	15.0	14.0	13.0		
		in.lb	163.7	132.8	115.1	106.2	106.2	132.8	123.9	115.1		
Max. torsional backlash	j_t	arcmin	Standard ≤ 4 / Reduced ≤ 2									
Torsional rigidity	C_{t21}	Nm/ arcmin	615	640	664	730	728	658	727	642		
		in.lb/ arcmin	5.443	5.664	5.876	6.461	6.443	5.823	6.434	5.682		
Tilting rigidity	C_{2K}	Nm/ arcmin	5560									
		in.lb/ arcmin	49206									
Max. axial force ^{e)}	F_{2AMax}	N	33000									
		lb _f	7425									
Max. tilting moment	M_{2KMax}	Nm	5900									
		in.lb	52215									
Efficiency at full load	η	%	94									
Service life (For calculation, see the Chapter "Information")	L_h	h	> 20000									
Weight incl. standard adapter plate	<i>m</i>	kg	83									
		lb _m	183									
Operating noise (with $n_1=3000$ rpm no load)	L_{PA}	dB(A)	≤ 71									
Max. permitted housing temperature		°C	+90									
		F	+194									
Ambient temperature		°C	0 to +40									
		F	32 to 104									
Lubrication			Lubricated for life									
Paint			Blue RAL 5002									
Direction of rotation			Motor and gearhead opposite directions									
Protection class			IP 65									
Moment of inertia (relates to the drive) Clamping hub diameter [mm]	M	48	J_1	kgcm ²	74.00	52.00	43.00	43.00	35.00	30.00	30.00	30.00
				10 ⁻³ in.lb.s ²	65.49	46.02	38.06	38.06	30.98	26.55	26.55	26.55

Please contact us for information on the best configuration for S1 conditions of use (continuous operation).

^{a)} Other ratios available on request

^{b)} Higher speeds are possible if the nominal torque is reduced

^{c)} For higher ambient temperatures, please reduce input speed

^{d)} Idling torques decrease during operation

^{e)} Refers to center of the output shaft or flange

All technical data for front output side applies.

Please request information for rear output side versions.

View A

2-stage:

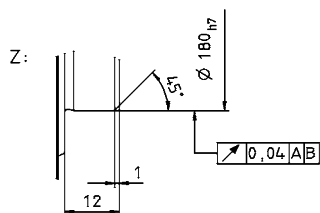
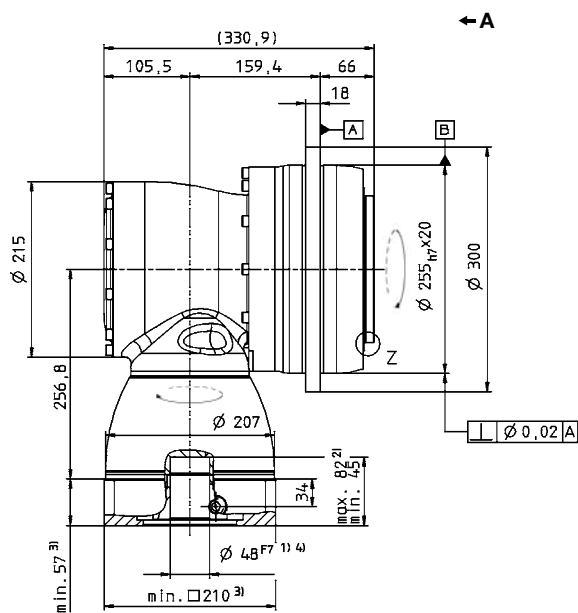
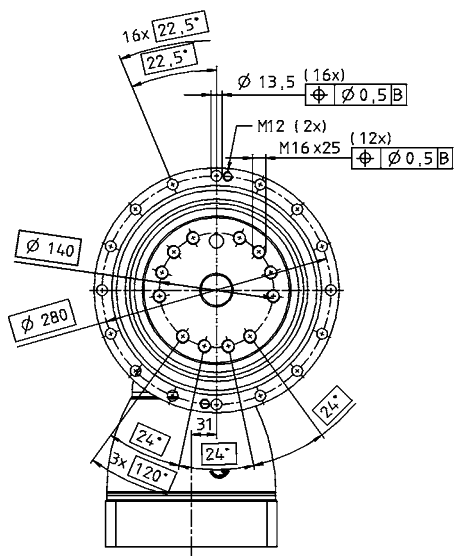

See technical data sheet for available clamping hub diameters (mass moment of inertia). Dimensions available on request.

Non-tolerated dimensions ± 1 mm

- 1) Check motor shaft fit.
- 2) Min./Max. permissible motor shaft length. Longer motor shafts are adaptable, please contact us.
- 3) The dimensions depend on the motor.
- 4) Smaller motor shaft diameter is compensated by a bushing with a minimum thickness of 1 mm.

Motor mounting according to operating manual



TPK+ 300 MF 3-stage

		3-stage														
Ratio ^{a)}	<i>i</i>		63	100	125	140	175	200	250	280	350	500	700	1000		
Max. acceleration torque (max. 1000 cycles per hour)	T_{2B}	Nm	3300	3200	3200	3200	3200	3200	3200	3300	3300	2350	3300	2800		
		in.lb	29205	28320	28320	28320	28320	28320	28320	29205	29205	20798	29205	24780		
Nominal output torque (with n_m)	T_{2N}	Nm	1800	2000	2000	2000	2000	2000	2000	1800	1800	1800	1800	1600		
		in.lb	15.930	17.700	17.700	17.700	17.700	17.700	17.700	15.930	15.930	15.930	15.930	14.160		
Emergency stop torque (permitted 1000 times during the service life of the gearhead)	T_{2Not}	Nm	6300	5250	5250	5250	5250	5250	5250	7350	7350	4500	6300	8750		
		in.lb	55755	46463	46463	46463	46463	46463	46463	65048	65048	39825	55755	77438		
Nominal input speed (with T_{2N} and 20 °C ambient temperature) ^{b), c)}	n_{1N}	rpm	2700	2700	2700	2700	2700	2700	2900	2700	2900	3400	3400	3400		
Max. continuous speed (with 20 % T_{2N} and 20 °C ambient temperature)	n_{1Nocym}	rpm	3200	3500	3500	3500	3500	3500	3500	3500	3500	3800	3800	3800		
Max. input speed	n_{1Max}	rpm	4000	4000	4000	4000	4000	4000	4000	4000	4000	4000	4000	4000		
Mean no load running torque (with $n_1=3000$ rpm and 20 °C gearhead temperature) ^{d)}	T_{012}	Nm	5.4	3.0	2.5	2.1	1.9	1.5	1.4	1.3	1.2	1.1	1.1	1.0		
		in.lb	47.8	26.6	22.1	18.6	16.8	13.3	12.4	0.0	10.6	9.7	9.7	8.9		
Max. torsional backlash	j_t	arcmin	Standard ≤ 4 / Reduced ≤ 2													
Torsional rigidity	C_{t21}	Nm/ arcmin	699	640	664	640	664	640	664	715	730	658	727	642		
		in.lb/ arcmin	6.186	5.664	5.876	5.664	5.876	5.664	5.876	6.328	6.461	5.823	6.434	5.682		
Tilting rigidity	C_{2K}	Nm/ arcmin	5560													
		in.lb/ arcmin	49210													
Max. axial force ^{e)}	F_{2AMax}	N	33000													
		lb _f	7425													
Max. tilting moment	M_{2KMax}	Nm	5900													
		in.lb	52215													
Efficiency at full load	η	%	92													
Service life (For calculation, see the Chapter "Information")	L_h	h	> 20000													
Weight incl. standard adapter plate	<i>m</i>	kg	87													
		lb _m	192													
Operating noise (with $n_1=3000$ rpm no load)	L_{PA}	dB(A)	≤ 71													
Max. permitted housing temperature		°C	+90													
		F	+194													
Ambient temperature		°C	0 to +40													
		F	32 to 104													
Lubrication			Lubricated for life													
Paint			Blue RAL 5002													
Direction of rotation			Motor and gearhead opposite directions													
Protection class			IP 65													
Moment of inertia (relates to the drive) Clamping hub diameter [mm]	K	38	J_1	kgcm ²	17.80	14.10	12.10	11.00	10.80	10.20	10.10	10.10	10.00	9.90	9.90	9.90
				10 ⁻³ in.lb.s ²	15.75	12.48	10.71	9.74	9.56	9.03	8.94	8.94	8.85	8.76	8.76	8.76
	M	48	J_1	kgcm ²	32.50	28.80	26.80	25.70	25.50	24.90	24.80	24.90	24.80	24.60	24.60	24.60
				10 ⁻³ in.lb.s ²	28.76	25.49	23.72	22.74	22.57	22.04	21.95	22.04	21.95	21.77	21.77	21.77

Please contact us for information on the best configuration for S1 conditions of use (continuous operation).

^{a)} Other ratios available on request

^{b)} Higher speeds are possible if the nominal torque is reduced

^{c)} For higher ambient temperatures, please reduce input speed

^{d)} Idling torques decrease during operation

^{e)} Refers to center of the output shaft or flange

All technical data for front output side applies.
Please request information for rear output side versions.

View A

3-stage:

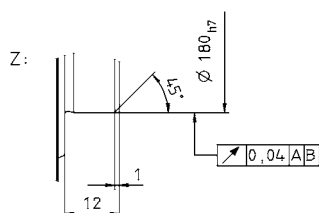
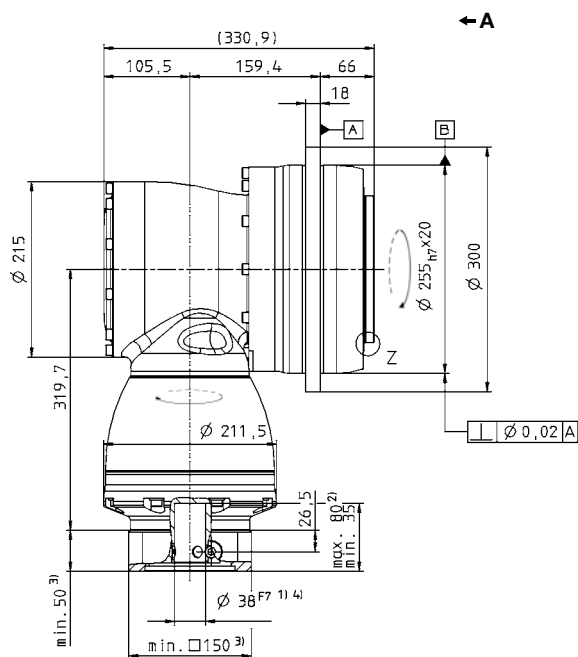
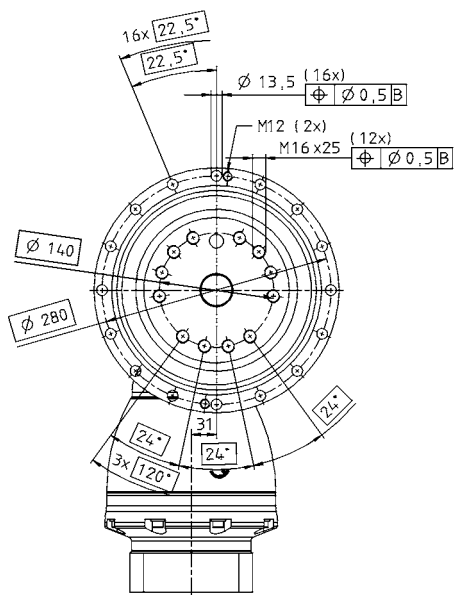

See technical data sheet for available clamping hub diameters (mass moment of inertia). Dimensions available on request.

Non-tolerated dimensions ± 1 mm

- 1) Check motor shaft fit.
- 2) Min./Max. permissible motor shaft length. Longer motor shafts are adaptable, please contact us.
- 3) The dimensions depend on the motor.
- 4) Smaller motor shaft diameter is compensated by a bushing with a minimum thickness of 1 mm.

Motor mounting according to operating manual



TPK+ 300 MA HIGH TORQUE® 3/4-stage

				3-stage							4-stage									
Ratio ^{a)}		<i>i</i>	66	88	110	137.5	154	220	385	330	462	577.5	770	1078	1540	2695	3850	5500		
Max. acceleration torque (max. 1000 cycles per hour)	T_{2B}	Nm	5500	5500	5500	5500	5500	4600	5500	5500	5500	5500	5500	5500	5500	5500	5500	5500	3900	
		in.lb	48675	48675	48675	48675	48675	40710	48675	48675	48675	48675	48675	48675	48675	48675	48675	48675	48675	34515
Nominal output torque (with n_{1N})	T_{2N}	Nm	3500	3500	3500	3500	3500	3500	3500	3500	3500	3500	3500	3500	3500	3500	3500	3500	3500	
		in.lb	30975	30975	30975	30975	30975	30975	30975	30975	30975	30975	30975	30975	30975	30975	30975	30975	30975	
Emergency stop torque (permitted 1000 times during the service life of the gearhead)	T_{2Not}	Nm	8800	11000	11000	11000	9900	8800	13250	8800	13250	11000	13250	13250	13250	13250	13250	13250	13250	
		in.lb	77880	97350	97350	97350	87615	77880	117263	77880	117263	97350	117263	117263	117263	117263	117263	117263	117263	
Nominal input speed (with T_{2N} and 20 °C ambient temperature) ^{b), c)}	n_{1N}	rpm	1800	1900	2100	2100	1900	1900	1900	2800	2800	2800	2800	2800	2800	3100	3800	3800		
Max. continuous speed (with 20 % T_{2N} and 20 °C ambient temperature)	n_{1Nocm}	rpm	2300	2600	2900	2900	2600	2600	2600	3800	3800	3800	3800	3800	3800	4000	4000	4000		
Max. input speed	n_{1Max}	rpm	4500	4500	4500	4500	4500	4500	4500	4500	4500	4500	4500	4500	4500	4500	4500	4500		
Mean no load running torque (with $n_1=3000$ rpm and 20 °C gearhead temperature) ^{d)}	T_{012}	Nm	11.0	8.2	6.9	6.5	9.2	6.7	6.4	1.5	2.2	1.0	0.9	0.8	0.6	0.4	0.4	0.4		
		in.lb	97.4	72.6	61.1	57.5	81.4	59.3	56.6	13.3	19.5	8.9	8.0	7.1	5.3	3.5	3.5	3.5		
Max. torsional backlash	j_t	arcmin	Standard $\leq 3,3$ / Reduced $\leq 1,8$																	
Torsional rigidity	C_{t21}	Nm/ arcmin	1099	1108	1114	960	1114	1111	979	1099	976	953	958	978	978	979	979	989		
		in.lb/ arcmin	9727	9809	9856	8499	9856	9834	8662	9727	8634	8437	8476	8655	8655	8667	8662	8757		
Tilting rigidity	C_{2K}	Nm/ arcmin	5560																	
		in.lb/ arcmin	49210																	
Max. axial force ^{e)}	F_{2AMax}	N	33000																	
		lb _f	7425																	
Max. tilting moment	M_{2KMax}	Nm	6500																	
		in.lb	57525																	
Efficiency at full load	η	%	92							90										
Service life (For calculation, see the Chapter "Information")	L_h	h	> 20000																	
Weight incl. standard adapter plate	<i>m</i>	kg	83							87										
		lb _m	183							192										
Operating noise (with $n_1=3000$ rpm no load)	L_{PA}	dB(A)	≤ 71																	
Max. permitted housing temperature		°C	+90																	
		F	+194																	
Ambient temperature		°C	0 to +40																	
		F	32 to 104																	
Lubrication			Lubricated for life																	
Paint			Blue RAL 5002																	
Direction of rotation			Motor and gearhead opposite directions																	
Protection class			IP 65																	
Moment of inertia (relates to the drive) Clamping hub diameter [mm]	G	24	J_1	kgcm ²	-	-	-	-	-	-	3.32	4.24	2.80	2.79	2.79	2.49	2.43	2.42	2.42	
				10 ⁻³ in.lb.s ²	-	-	-	-	-	-	2.94	3.75	2.48	2.47	2.47	2.20	2.15	2.14	2.14	
	K	38	J_1	kgcm ²	26.04	19.71	16.71	16.58	14.26	12.89	12.83	10.23	11.15	9.71	9.70	9.70	9.40	9.34	9.33	9.33
				10 ⁻³ in.lb.s ²	23.05	17.44	14.78	14.67	12.62	11.41	11.36	9.06	9.87	8.59	8.59	8.58	8.32	8.27	8.26	8.26

Please contact us for information on the best configuration for S1 conditions of use (continuous operation).

^{a)} Other ratios available on request

^{b)} Higher speeds are possible if the nominal torque is reduced

^{c)} For higher ambient temperatures, please reduce input speed

^{d)} Idling torques decrease during operation

^{e)} Refers to center of the output shaft or flange

All technical data for front output side applies.

Please request information for rear output side versions.

View A

3-stage:

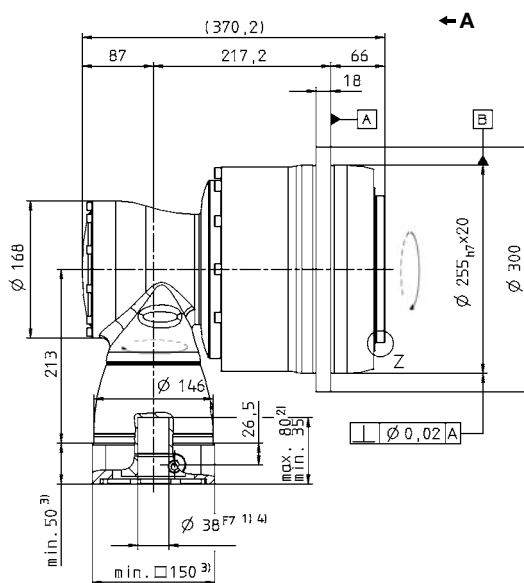
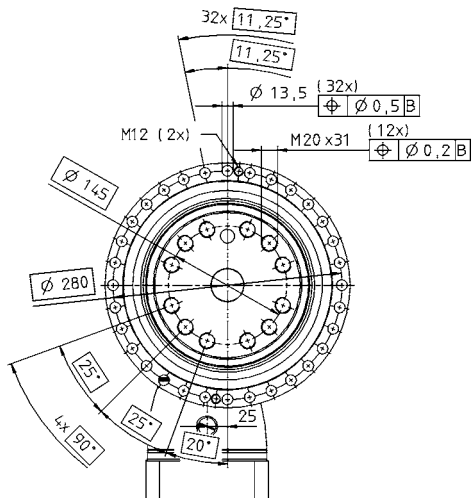

4-stage:

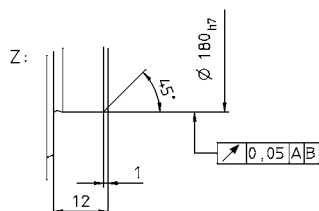
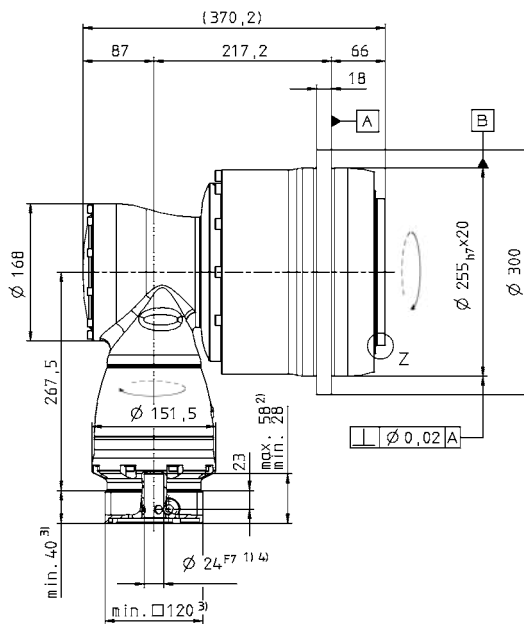
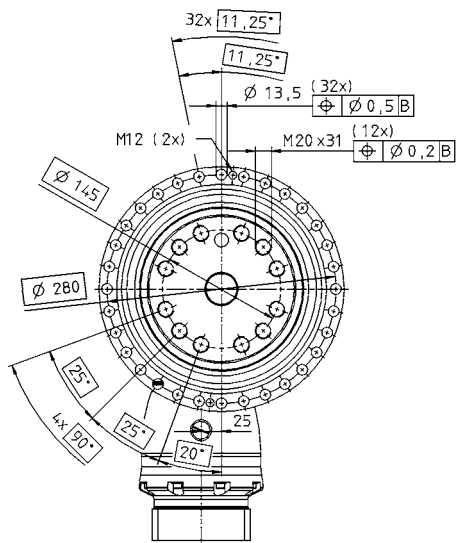

See technical data sheet for available clamping hub diameters (mass moment of inertia). Dimensions available on request.

Non-tolerated dimensions ±1 mm

- 1) Check motor shaft fit.
- 2) Min./Max. permissible motor shaft length. Longer motor shafts are adaptable, please contact us.
- 3) The dimensions depend on the motor.
- 4) Smaller motor shaft diameter is compensated by a bushing with a minimum thickness of 1 mm.

⚠ Motor mounting according to operating manual



TPK+ 500 MF 3-stage

		3-stage												
Ratio ^{a)}	<i>i</i>	100	125	140	175	200	250	350	500	700	1000			
Max. acceleration torque (max. 1000 cycles per hour)	T_{2B}	Nm	6000	6000	5000	6000	4200	5250	6000	4500	5000	4800		
		in.lb	53100	53100	44250	53100	37170	46463	53100	39825	44250	42480		
Nominal output torque (with n_m)	T_{2N}	Nm	3350	3800	3350	3800	3350	3800	3800	2900	2800	2900		
		in.lb	29648	33630	29648	33630	29648	33630	33630	25665	24780	25665		
Emergency stop torque (permitted 1000 times during the service life of the gearhead)	T_{2Not}	Nm	10000	12500	9000	11250	8000	10000	14000	15000	15000	15000		
		in.lb	88500	110625	79650	99563	70800	88500	123900	132750	132750	132750		
Nominal input speed (with T_{2N} and 20 °C ambient temperature) ^{b), c)}	n_{1N}	rpm	2100	2100	1900	1900	1900	1900	1900	1900	1900			
Max. continuous speed (with 20 % T_{2N} and 20 °C ambient temperature)	n_{1Nocym}	rpm	2900	2900	2600	2600	2600	2600	2600	2600	2600			
Max. input speed	n_{1Max}	rpm	4500	4500	4500	4500	4500	4500	4500	4500	4500			
Mean no load running torque (with $n_1=3000$ rpm and 20 °C gearhead temperature) ^{d)}	T_{012}	Nm	5.5	5.5	8.5	8.5	6.0	6.0	6.0	6.0	6.0	6.0		
		in.lb	48.7	48.7	75.2	75.2	53.1	53.1	53.1	53.1	53.1	53.1		
Max. torsional backlash	j_t	arcmin	Standard $\leq 3,3$ / Reduced $\leq 2,3$											
Torsional rigidity	C_{t21}	Nm/ arcmin	1250	1350	1250	1350	1250	1350	1350	1280	1240	1050		
		in.lb/ arcmin	11063	11948	11063	11948	11063	11948	11948	11328	10974	9293		
Tilting rigidity	C_{2K}	Nm/ arcmin	9480											
		in.lb/ arcmin	83898											
Max. axial force ^{e)}	F_{2AMax}	N	50000											
		lb _f	11250											
Max. tilting moment	M_{2KMax}	Nm	8800											
		in.lb	77880											
Efficiency at full load	η	%	92											
Service life (For calculation, see the Chapter "Information")	L_h	h	> 20000											
Weight incl. standard adapter plate	<i>m</i>	kg	96											
		lb _m	212											
Operating noise (with $n_1=3000$ rpm no load)	L_{PA}	dB(A)	≤ 71											
Max. permitted housing temperature		°C	+90											
		F	+194											
Ambient temperature		°C	0 to +40											
		F	32 to 104											
Lubrication			Lubricated for life											
Paint			Blue RAL 5002											
Direction of rotation			Motor and gearhead opposite directions											
Protection class			IP 65											
Moment of inertia (relates to the drive) Clamping hub diameter [mm]	K	38	J_1	kgcm ²	16.70	16.70	16.50	16.50	16.40	16.40	16.40	16.40	16.40	16.40
				10 ⁻³ in.lb.s ²	14.78	14.78	14.60	14.60	14.51	14.51	14.51	14.51	14.51	14.51

Please contact us for information on the best configuration for S1 conditions of use (continuous operation).

^{a)} Other ratios available on request

^{b)} Higher speeds are possible if the nominal torque is reduced

^{c)} For higher ambient temperatures, please reduce input speed

^{d)} Idling torques decrease during operation

^{e)} Refers to center of the output shaft or flange

All technical data for front output side applies.

Please request information for rear output side versions.

View A

3-stage:

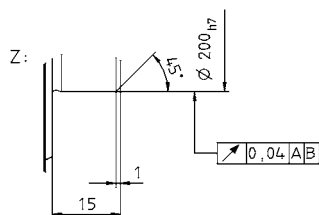
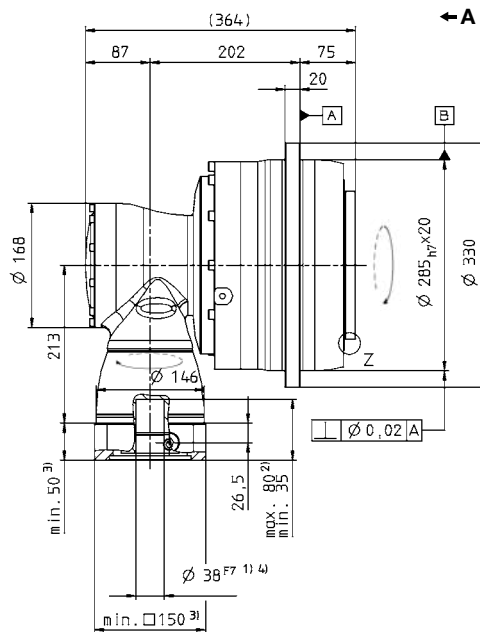
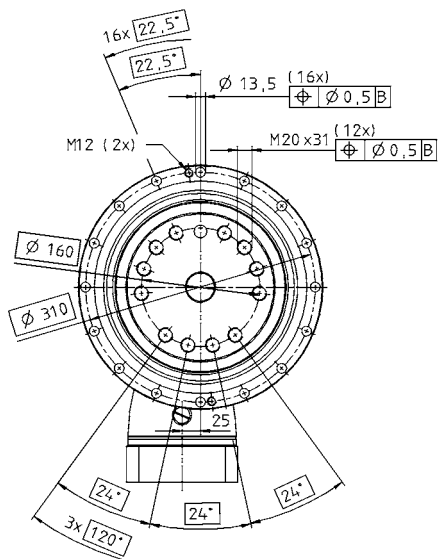

See technical data sheet for available clamping hub diameters (mass moment of inertia). Dimensions available on request.

Non-tolerated dimensions ± 1 mm

- 1) Check motor shaft fit.
- 2) Min./Max. permissible motor shaft length. Longer motor shafts are adaptable, please contact us.
- 3) The dimensions depend on the motor.
- 4) Smaller motor shaft diameter is compensated by a bushing with a minimum thickness of 1 mm.

Motor mounting according to operating manual



TPK+ 500 MF 4-stage i=180-1000

		4-stage														
Ratio ^{a)}	<i>i</i>		180	240	300	375	420	500	560	600	700	800	875	1000		
Max. acceleration torque (max. 1000 cycles per hour)	T_{2B}	Nm	6000	6000	6000	6000	6000	6000	6000	6000	6000	6000	6000	6000		
		in.lb	53100	53100	53100	53100	53100	53100	53100	53100	53100	53100	53100	53100		
Nominal output torque (with n_m)	T_{2N}	Nm	3350	3350	3350	3800	3350	3350	3350	3350	3350	3350	3800	3350		
		in.lb	29648	29648	29648	33630	29648	29648	29648	29648	29648	29648	33630	29648		
Emergency stop torque (permitted 1000 times during the service life of the gearhead)	T_{2Not}	Nm	10000	10000	10000	12500	10000	10000	10000	10000	10000	10000	12500	10000		
		in.lb	88500	88500	88500	110625	88500	88500	88500	88500	88500	88500	110625	88500		
Nominal input speed (with T_{2N} and 20 °C ambient temperature) ^{b), c)}	n_{1N}	rpm	2700	2900	2900	2900	2900	2900	2900	2900	2900	2900	2900	3200		
Max. continuous speed (with 20 % T_{2N} and 20 °C ambient temperature)	n_{1Nocym}	rpm	3800	4000	4000	4000	4000	4000	4000	4000	4000	4000	4000	4200		
Max. input speed	n_{1Max}	rpm	4500	4500	4500	4500	4500	4500	4500	4500	4500	4500	4500	4500		
Mean no load running torque (with $n_1=3000$ rpm and 20 °C gearhead temperature) ^{d)}	T_{012}	Nm	3.4	2.5	1.6	1.4	1.1	1	1	0.8	0.8	0.7	0.7	0.6		
		in.lb	30.1	22.1	14.2	12.4	9.7	8.9	8.9	7.1	7.1	6.2	6.2	5.3		
Max. torsional backlash	j_t	arcmin	Standard $\leq 3,3$ / Reduced $\leq 2,3$													
Torsional rigidity	C_{t21}	Nm/ arcmin	1250	1250	1250	1300	1250	1350	1250	1250	1262	1250	1350	1250		
		in.lb/ arcmin	11063	11063	11063	11505	11063	11948	11063	11063	11169	11063	11948	11063		
Tilting rigidity	C_{2K}	Nm/ arcmin	9480													
		in.lb/ arcmin	83906													
Max. axial force ^{e)}	F_{2AMax}	N	50000													
		lb _f	11250													
Max. tilting moment	M_{2KMax}	Nm	8800													
		in.lb	77880													
Efficiency at full load	η	%	90													
Service life (For calculation, see the Chapter "Information")	L_h	h	> 20000													
Weight incl. standard adapter plate	m	kg	99													
		lb _m	219													
Operating noise (with $n_1=3000$ rpm no load)	L_{PA}	dB(A)	≤ 71													
Max. permitted housing temperature		°C	+90													
		F	+194													
Ambient temperature		°C	0 to +40													
		F	32 to 104													
Lubrication			Lubricated for life													
Paint			Blue RAL 5002													
Direction of rotation			Motor and gearhead opposite directions													
Protection class			IP 65													
Moment of inertia (relates to the drive) Clamping hub diameter [mm]	G	24	J_1	kgcm ²	5.93	4.29	3.33	3.32	2.81	3.19	2.80	2.50	2.74	2.49	2.74	2.46
				10 ⁻³ in.lb.in. ²	5.25	3.79	2.95	2.94	2.49	2.82	2.48	2.21	2.42	2.20	2.42	2.18
	K	38	J_1	kgcm ²	12.84	11.18	10.24	10.23	9.72	10.10	9.71	9.41	9.65	9.40	9.65	9.37
				10 ⁻³ in.lb.in. ²	11.37	9.89	9.06	9.06	8.60	8.94	8.59	8.33	8.54	8.32	8.54	8.29

Please contact us for information on the best configuration for S1 conditions of use (continuous operation).

^{a)} Other ratios available on request

^{b)} Higher speeds are possible if the nominal torque is reduced

^{c)} For higher ambient temperatures, please reduce input speed

^{d)} Idling torques decrease during operation

^{e)} Refers to center of the output shaft or flange

All technical data for front output side applies.
Please request information for rear output side versions.

View A

4-stage:

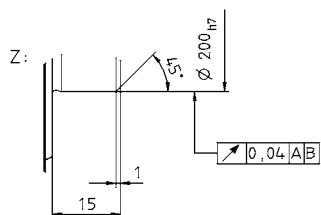
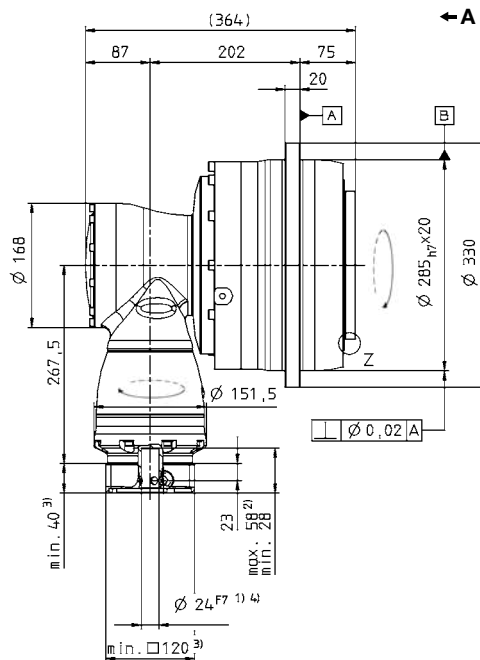
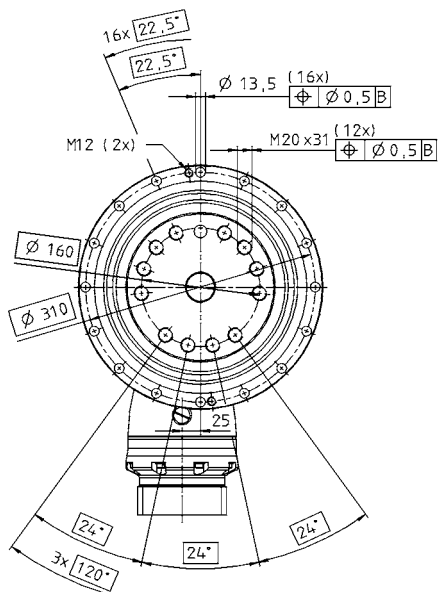

See technical data sheet for available clamping hub diameters (mass moment of inertia). Dimensions available on request.

Non-tolerated dimensions ± 1 mm

- 1) Check motor shaft fit.
- 2) Min./Max. permissible motor shaft length. Longer motor shafts are adaptable, please contact us.
- 3) The dimensions depend on the motor.
- 4) Smaller motor shaft diameter is compensated by a bushing with a minimum thickness of 1 mm.

Motor mounting according to operating manual

TK-
TPK-



TPK+ 500 MF 4-stage i=1225-10000

		4-stage											
Ratio ^{a)}	<i>i</i>		1225	1400	1750	2000	2800	3500	5000	7000	10000		
Max. acceleration torque (max. 1000 cycles per hour)	T_{2B}	Nm	6000	6000	6000	4200	5000	6000	4500	5000	4800		
		in.lb	53100	53100	53100	37170	44250	53100	39825	44250	42480		
Nominal output torque (with n_m)	T_{2N}	Nm	3800	3800	3800	3200	2800	3800	2900	2800	2900		
		in.lb	33630	33630	33630	28320	24780	33630	25665	24780	25665		
Emergency stop torque (permitted 1000 times during the service life of the gearhead)	T_{2Not}	Nm	15000	15000	15000	8000	11200	14000	15000	15000	15000		
		in.lb	132750	132750	132750	70800	99120	123900	132750	132750	132750		
Nominal input speed (with T_{2N} and 20 °C ambient temperature) ^{b), c)}	n_{1N}	rpm	2900	2900	3200	3900	3900	3900	3900	3900	3900		
Max. continuous speed (with 20 % T_{2N} and 20 °C ambient temperature)	n_{1Nocym}	rpm	4000	4000	4200	4200	4200	4200	4200	4200	4200		
Max. input speed	n_{1Max}	rpm	4500	4500	4500	4500	4500	4500	4500	4500	4500		
Mean no load running torque (with $n_1=3000$ rpm and 20 °C gearhead temperature) ^{d)}	T_{012}	Nm	0.6	0.6	0.4	0.4	0.4	0.4	0.4	0.4	0.4		
		in.lb	5.3	5.3	3.5	3.5	3.5	3.5	3.5	3.5	3.5		
Max. torsional backlash	j_t	arcmin	Standard $\leq 3,3$ / Reduced $\leq 2,3$										
Torsional rigidity	C_{t21}	Nm/ arcmin	1350	1350	1350	1250	1250	1350	1250	1250	1050		
		in.lb/ arcmin	11948	11948	11948	11063	11063	11948	11063	11063	9293		
Tilting rigidity	C_{2K}	Nm/ arcmin	9480										
		in.lb/ arcmin	83906										
Max. axial force ^{e)}	F_{2AMax}	N	50000										
		lb _f	11250										
Max. tilting moment	M_{2KMax}	Nm	8800										
		in.lb	77880										
Efficiency at full load	η	%	90										
Service life (For calculation, see the Chapter "Information")	L_h	h	> 20000										
Weight incl. standard adapter plate	<i>m</i>	kg	99										
		lb _m	219										
Operating noise (with $n_1=3000$ rpm no load)	L_{PA}	dB(A)	≤ 71										
Max. permitted housing temperature		°C	+90										
		F	+194										
Ambient temperature		°C	0 to +40										
		F	32 to 104										
Lubrication			Lubricated for life										
Paint			Blue RAL 5002										
Direction of rotation			Motor and gearhead opposite directions										
Protection class			IP 65										
Moment of inertia (relates to the drive)	G	24	J_1	kgcm ²	2.73	2.49	2.46	2.42	2.42	2.42	2.42	2.42	2.42
				10 ⁻³ in.lb.s ²	2.42	2.20	2.17	2.14	2.14	2.14	2.14	2.14	2.14
Clamping hub diameter [mm]	K	38	J_1	kgcm ²	9.64	9.40	9.37	9.33	9.33	9.33	9.33	9.33	9.33
				10 ⁻³ in.lb.s ²	8.53	8.32	8.29	8.26	8.26	8.26	8.26	8.26	8.26

Please contact us for information on the best configuration for S1 conditions of use (continuous operation).

^{a)} Other ratios available on request

^{b)} Higher speeds are possible if the nominal torque is reduced

^{c)} For higher ambient temperatures, please reduce input speed

^{d)} Idling torques decrease during operation

^{e)} Refers to center of the output shaft or flange

All technical data for front output side applies.
Please request information for rear output side versions.

View A

4-stage:

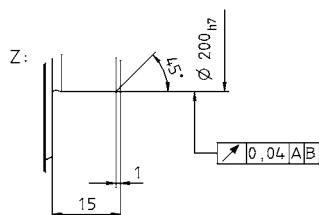
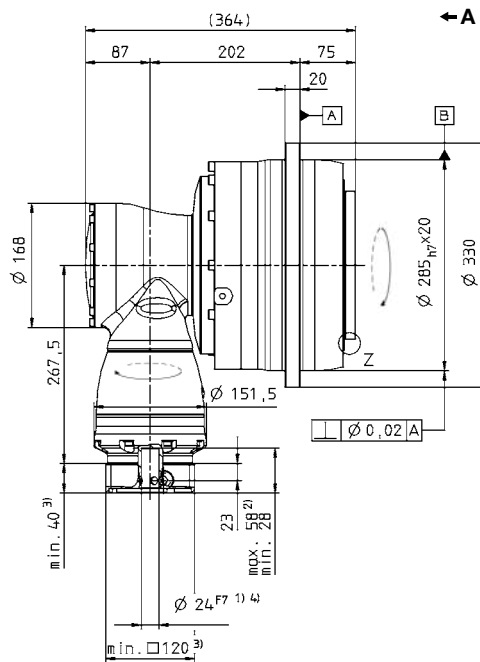
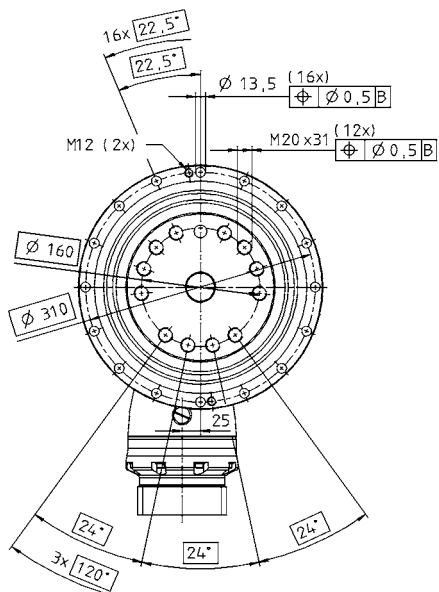

See technical data sheet for available clamping hub diameters (mass moment of inertia). Dimensions available on request.

Non-tolerated dimensions ± 1 mm

- 1) Check motor shaft fit.
- 2) Min./Max. permissible motor shaft length. Longer motor shafts are adaptable, please contact us.
- 3) The dimensions depend on the motor.
- 4) Smaller motor shaft diameter is compensated by a bushing with a minimum thickness of 1 mm.

Motor mounting according to operating manual

TK-
TPK-



TPK+ 500 MA HIGH TORQUE® 3/4-stage

		3-stage								4-stage									
Ratio ^{a)}	<i>i</i>	66	88	110	137,5	154	220	385	330	462	577,5	770	1078	1540	2695	3850	5500		
Max. acceleration torque (max. 1000 cycles per hour)	T_{2B}	Nm	10000	10000	10000	10000	10000	10000	10000	10000	10000	10000	10000	10000	10000	10000	10000	7200	
		in.lb	88500	88500	88500	88500	88500	88500	88500	88500	88500	88500	88500	88500	88500	88500	88500	88500	63720
Nominal output torque (with n_{2N})	T_{2N}	Nm	5400	5400	5400	5400	5400	5400	5400	5400	5400	5400	5400	5400	5400	5400	5400	5400	
		in.lb	47790	47790	47790	47790	47790	47790	47790	47790	47790	47790	47790	47790	47790	47790	47790	47790	
Emergency stop torque (permitted 1000 times during the service life of the gearhead)	T_{2Not}	Nm	19800	23000	23000	25000	21300	19800	25000	19800	25000	25000	25000	25000	25000	25000	25000	25000	
		in.lb	175230	203550	203550	221250	188505	175230	221250	175230	221250	221250	221250	221250	221250	221250	221250	221250	
Nominal input speed (with T_{2N} and 20 °C ambient temperature) ^{b), c)}	n_{1N}	rpm	1500	1700	1900	1900	1700	1700	2600	2600	2600	2600	2600	2600	3100	3300	3300		
Max. continuous speed (with 20 % T_{2N} and 20 °C ambient temperature)	n_{1Nocym}	rpm	1800	2200	2600	2600	2300	2300	3300	3300	3300	3300	3300	3300	3600	3600	3600		
Max. input speed	n_{1Max}	rpm	4000	4000	4000	4000	4000	4000	4000	4000	4000	4000	4000	4000	4000	4000	4000		
Mean no load running torque (with $n_1=3000$ rpm and 20 °C gearhead temperature) ^{d)}	T_{012}	Nm	20.5	16.5	13.6	12.8	17.6	14.3	13.7	3.0	4.0	2.0	1.8	1.7	1.2	1.1	1.0		
		in.lb	181.4	146.0	120.4	113.3	155.8	126.6	121.2	26.6	35.4	17.7	15.9	15.0	10.6	9.7	8.9	8.9	
Max. torsional backlash	j_t	arcmin	Standard $\leq 3,3$ / Reduced $\leq 1,8$																
Torsional rigidity	C_{t21}	Nm/ arcmin	1879	1890	1901	1747	1899	1898	1772	1879	1766	1735	1742	1770	1770	1772	1772	1786	
		in.lb/ arcmin	16626	16727	16820	15464	16809	16799	15683	16626	15633	15359	15413	15662	15662	15686	15683	15808	
Tilting rigidity	C_{2K}	Nm/ arcmin	9480																
		in.lb/ arcmin	83906																
Max. axial force ^{e)}	F_{2AMax}	N	50000																
		lb _f	11250																
Max. tilting moment	M_{2KMax}	Nm	9500																
		in.lb	84075																
Efficiency at full load	η	%	92								90								
Service life (For calculation, see the Chapter "Information")	L_h	h	> 20000																
Weight incl. standard adapter plate	<i>m</i>	kg	120								124								
		lb _m	265								274								
Operating noise (with $n_1=3000$ rpm no load)	L_{PA}	dB(A)	≤ 71																
Max. permitted housing temperature		°C	+90																
		F	+194																
Ambient temperature		°C	0 to +40																
		F	32 to 104																
Lubrication			Lubricated for life																
Paint			Blue RAL 5002																
Direction of rotation			Motor and gearhead opposite directions																
Protection class			IP 65																
Moment of inertia (relates to the drive)	K 38	J_1	kgcm ²	-	-	-	-	-	-	-	12.43	15.36	10.93	10.92	10.91	10.13	9.95	9.91	9.91
			10 ⁻³ in.lb.s ²	-	-	-	-	-	-	-	-	11.00	13.59	9.67	9.66	9.66	8.96	8.81	8.77
Clamping hub diameter [mm]	M 48	J_1	kgcm ²	75.54	52.83	42.94	42.67	34.37	29.87	29.73	27.14	30.07	25.64	25.63	25.62	24.84	24.66	24.62	24.62
			10 ⁻³ in.lb.s ²	66.85	46.76	38.01	37.76	30.41	26.43	26.31	24.02	26.61	22.69	22.68	22.68	21.98	21.83	21.79	21.79

Please contact us for information on the best configuration for S1 conditions of use (continuous operation).

^{a)} Other ratios available on request

^{b)} Higher speeds are possible if the nominal torque is reduced

^{c)} For higher ambient temperatures, please reduce input speed

^{d)} Idling torques decrease during operation

^{e)} Refers to center of the output shaft or flange

All technical data for front output side applies.

Please request information for rear output side versions.

View A

3-stage:

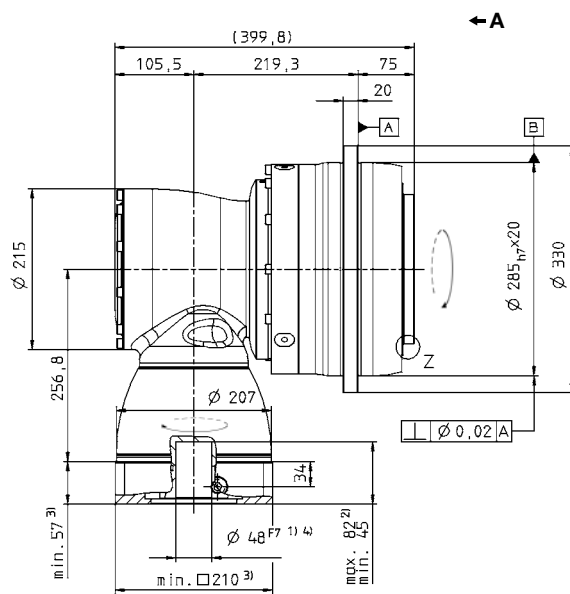
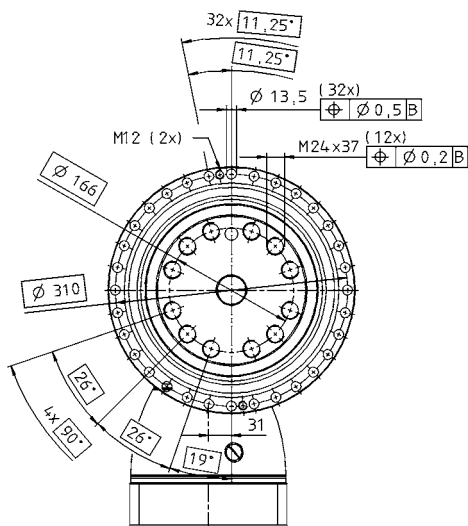

4-stage:

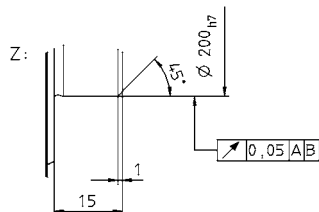
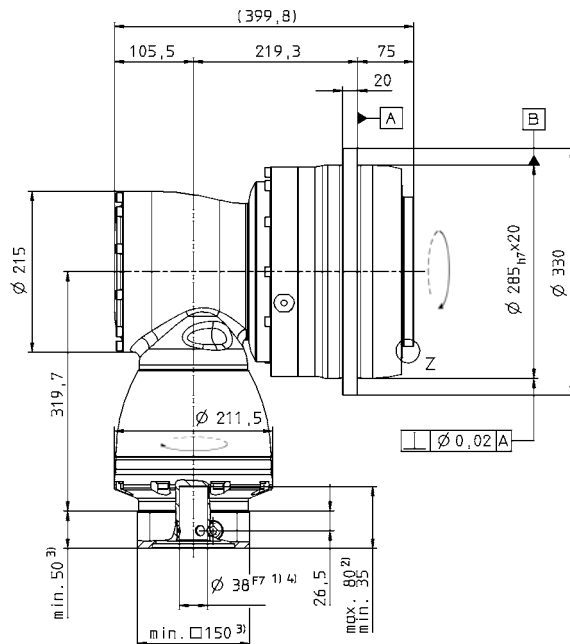
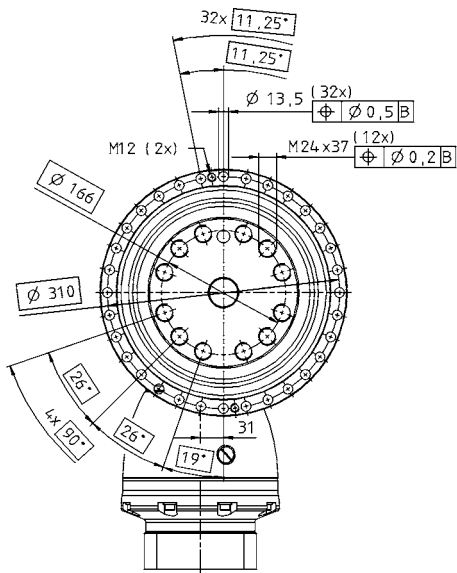

See technical data sheet for available clamping hub diameters (mass moment of inertia). Dimensions available on request.

Non-tolerated dimensions ± 1 mm

- 1) Check motor shaft fit.
- 2) Min./Max. permissible motor shaft length. Longer motor shafts are adaptable, please contact us.
- 3) The dimensions depend on the motor.
- 4) Smaller motor shaft diameter is compensated by a bushing with a minimum thickness of 1 mm.

⚠ Motor mounting according to operating manual



SK+/SPK+ – New right-angle precision

The successor to our versatile hypoid gearhead with SP+ compatible output shaft, also available with planetary stage

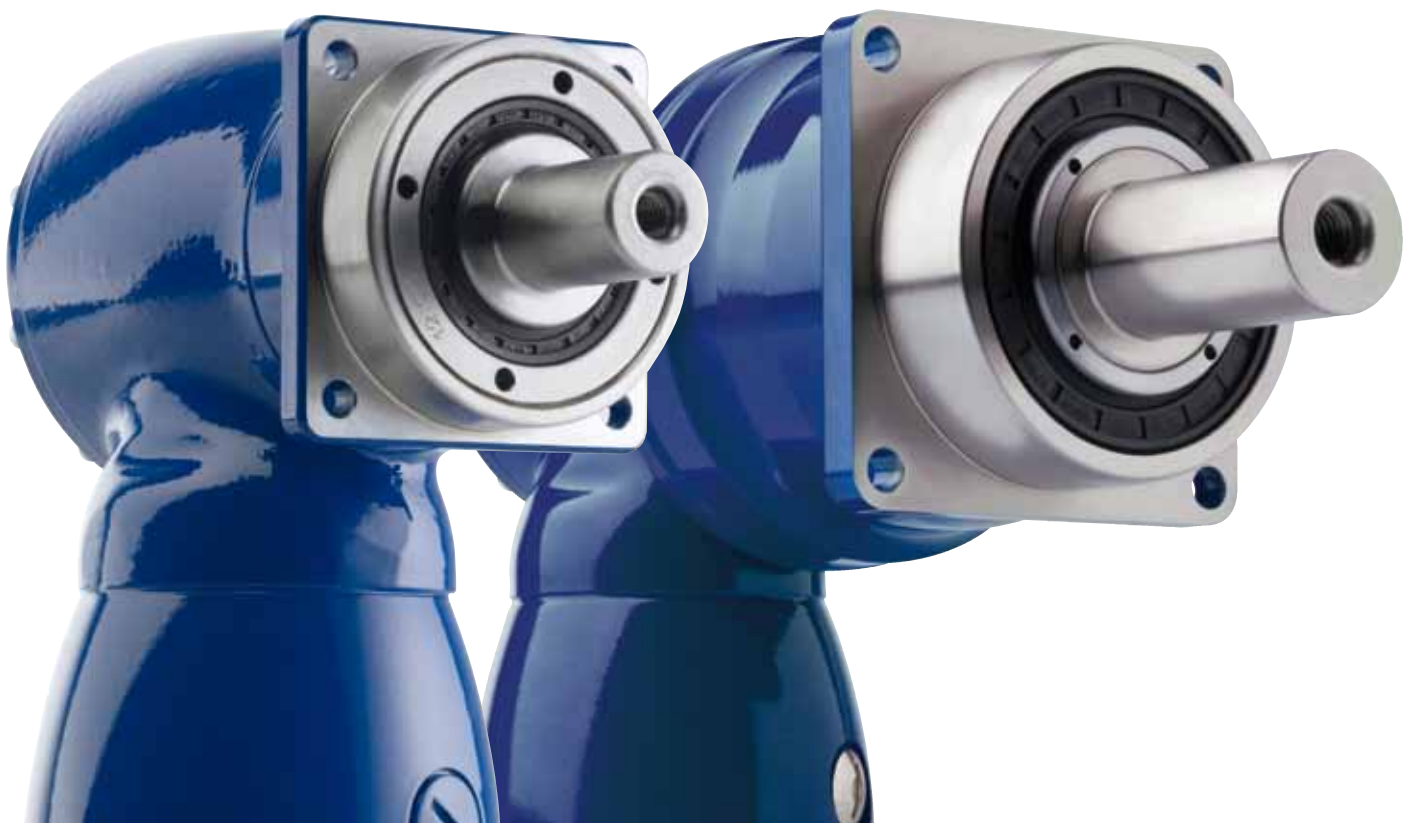

SK+/SPK+

Specifications \ Version	SK+/SPK+		
	+	++	+++
Positioning accuracy		SK+	
			SPK+
Rigidity	SK+		
		SPK+	
Smooth-running		SK+	
		SPK+	
Speed capacity		SK+	
		SPK+	
Power density	SK+		
		SPK+	
Max. axial/radial forces		SK+	
		SPK+	



Shrink disc



See our website and our separate flyer for more information about our washdown solutions



Couplings



Rack / Pinion

Options

- Plug-in drive coupling
- Smooth output shaft / with key / involute
- Washdown version
- ATEX version
- Food-grade grease

Accessories

- Rack / Pinion (see page 310)
- Shrink disc (see page 342)
- Couplings (see page 342)

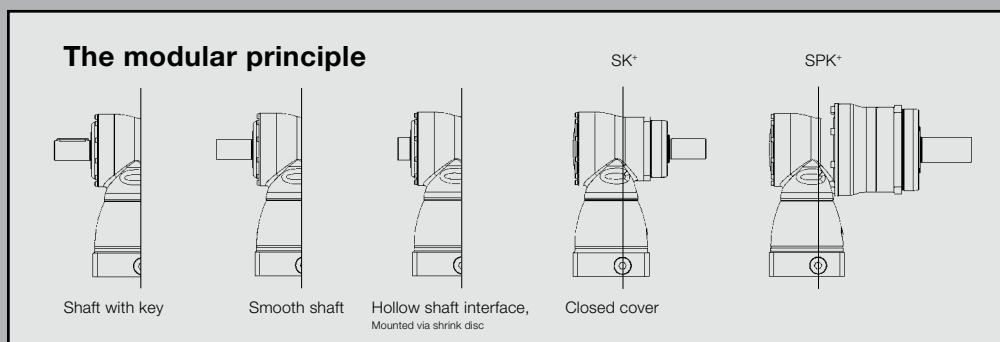

SK+ 060 MF 1/2-stage

		1-stage					2-stage											
Ratio ^{a)}	<i>i</i>	3	4	5	7	10	12	16	20	25	28	35	40	50	70	100		
Max. acceleration torque (max. 1000 cycles per hour)	T_{2B}	Nm	30	30	30	25	20	30	30	30	30	30	30	30	25	20		
		in.lb	266	266	266	221	177	266	266	266	266	266	266	266	266	221	177	
Nominal output torque (with n_{1N})	T_{2N}	Nm	22	22	22	20	15	22	22	22	22	22	22	22	20	15		
		in.lb	195	195	195	177	133	195	195	195	195	195	195	195	195	177	133	
Emergency stop torque (permitted 1000 times during the service life of the gearhead)	T_{2Not}	Nm	40	50	50	45	40	50	50	50	50	50	50	50	45	40		
		in.lb	354	443	443	398	354	443	443	443	443	443	443	443	443	398	354	
Nominal input speed (with T_{2N} and 20°C ambient temperature) ^{b), c)}	n_{1N}	rpm	2500	2700	3000	3000	3000	4400	4400	4400	4400	4400	4400	4800	5500	5500		
Max. continuous speed (with 20% T_{2N} and 20°C ambient temperature)	n_{1Ncym}	rpm	3000	3500	4000	3500	3500	5000	5000	5000	5000	5000	5000	5000	5500	5500		
Max. input speed	n_{1Max}	rpm	6000	6000	6000	6000	6000	6000	6000	6000	6000	6000	6000	6000	6000	6000		
Mean no load running torque (with $n_1=3000$ rpm and 20°C gearhead temperature) ^{d)}	T_{012}	Nm	1.2	1.1	1.0	1.2	1.1	0.2	0.2	0.2	0.2	0.2	0.2	0.1	0.1	0.1		
		in.lb	10.6	9.7	8.9	10.6	9.7	1.8	1.8	1.8	1.8	1.8	1.8	0.9	0.9	0.9	0.9	
Max. torsional backlash	j_t	arcmin	≤ 5															
Torsional rigidity	C_{t21}	Nm/arcmin	2.0	2.1	2.2	2.0	1.8	2.1	2.1	2.1	2.1	2.1	2.1	2.1	2.2	2.0	1.8	
		in.lb/arcmin	18	19	19	18	16	19	19	19	19	19	19	19	19	18	16	
Max. axial force ^{e)}	F_{2AMax}	N	2400															
		lb _f	540															
Max. radial force ^{e)}	F_{2RMax}	N	2700															
		lb _f	608															
Max. tilting moment	M_{2KMax}	Nm	251															
		in.lb	2220															
Efficiency at full load	η	%	96					94										
Service life (For calculation, see the Chapter "Information")	L_h	h	> 20000															
Weight incl. standard adapter plate	<i>m</i>	kg	2.9					3.2										
		lb _m	6.4					7.1										
Operating noise (with $n_1=3000$ rpm no load)	L_{PA}	dB(A)	≤ 64															
Max. permitted housing temperature	°C		+90															
	F		194															
Ambient temperature	°C		0 to +40															
	F		32 to 104															
Lubrication	Lubricated for life																	
Paint	Blue RAL 5002																	
Direction of rotation	Motor and gearhead opposite directions																	
Protection class	IP 65																	
Moment of inertia (relates to the drive) Clamping hub diameter [mm]	B	11	J_t	kgcm ²	-	-	-	-	-	0.09	0.09	0.07	0.07	0.06	0.06	0.06	0.06	
				10 ⁻³ in.lb.in. ²	-	-	-	-	-	0.08	0.08	0.07	0.06	0.06	0.06	0.05	0.05	0.05
	C	14	J_t	kgcm ²	0.52	0.44	0.40	0.36	0.34	0.20	0.20	0.19	0.19	0.18	0.18	0.17	0.17	0.17
				10 ⁻³ in.lb.in. ²	0.46	0.39	0.35	0.32	0.30	0.18	0.18	0.17	0.16	0.16	0.16	0.15	0.15	0.15
E	19	J_t	kgcm ²	0.87	0.79	0.75	0.71	0.70	-	-	-	-	-	-	-	-	-	
			10 ⁻³ in.lb.in. ²	0.77	0.70	0.66	0.63	0.62	-	-	-	-	-	-	-	-	-	-

Please contact us for information on the best configuration for S1 conditions of use (continuous operation).

^{a)} Other ratios available on request

^{b)} Higher speeds are possible if the nominal torque is reduced

^{c)} For higher ambient temperatures, please reduce input speed

^{d)} Idling torques decrease during operation

^{e)} Refers to center of the output shaft or flange

All technical data for front output side applies.

Please request information for rear output side versions.

View A

1-stage:

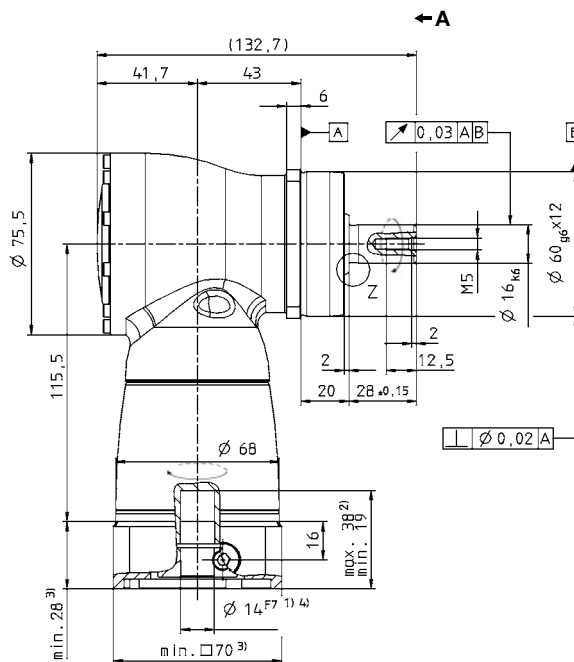
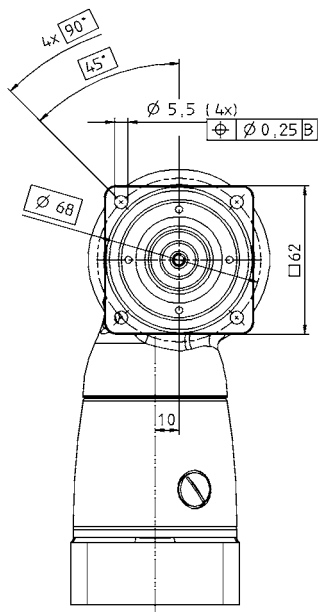

2-stage:

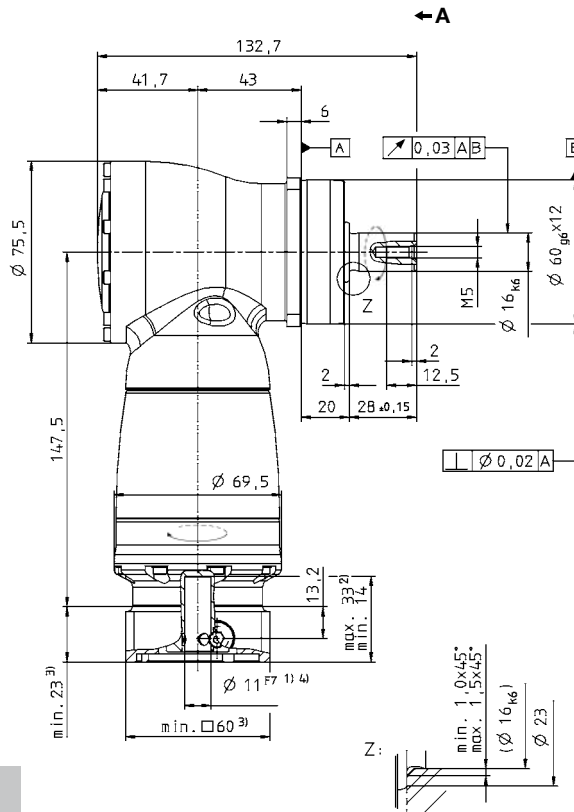
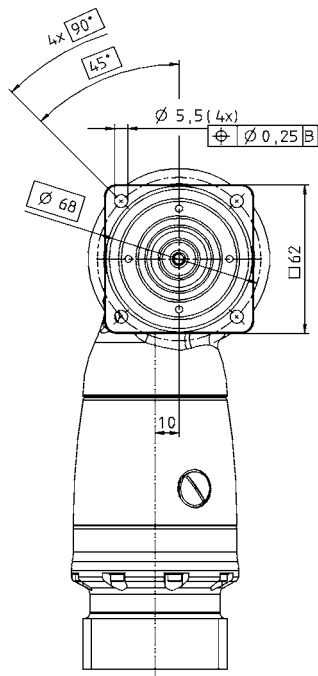

Alternatives: Output shaft variants

Keywayed output shaft in mm
E = key as per DIN 6885, sheet 1, form A

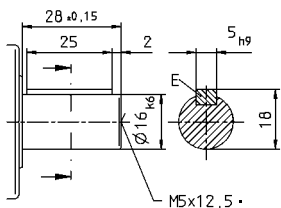

Involute gearing DIN 5480
X = W 16 x 0.8 x 30 x 18 x 6m, DIN 5480

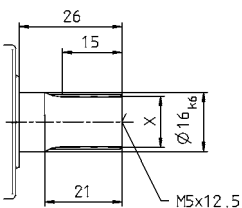

See technical data sheet for available clamping hub diameters (mass moment of inertia). Dimensions available on request.

Non-tolerated dimensions ±1 mm

- 1) Check motor shaft fit.
- 2) Min./Max. permissible motor shaft length. Longer motor shafts are adaptable, please contact us.
- 3) The dimensions depend on the motor.
- 4) Smaller motor shaft diameter is compensated by a bushing with a minimum thickness of 1 mm.

⚠ Motor mounting according to operating manual



SK+ 075 MF 1/2-stage

		1-stage					2-stage													
Ratio ^{a)}	<i>i</i>	3	4	5	7	10	12	16	20	25	28	35	40	50	70	100				
Max. acceleration torque (max. 1000 cycles per hour)	T_{2B}	Nm	70	70	70	60	50	70	70	70	70	70	70	70	60	50				
		in.lb	620	620	620	531	443	620	620	620	620	620	620	620	620	531	443			
Nominal output torque (with n_{1N})	T_{2N}	Nm	50	50	50	45	40	50	50	50	50	50	50	50	45	40				
		in.lb	443	443	443	398	354	443	443	443	443	443	443	443	443	398	354			
Emergency stop torque (permitted 1000 times during the service life of the gearhead)	T_{2Not}	Nm	95	115	115	110	100	115	115	115	115	115	115	115	110	100				
		in.lb	841	1018	1018	974	885	1018	1018	1018	1018	1018	1018	1018	1018	974	885			
Nominal input speed (with T_{2N} and 20°C ambient temperature) ^{b), c)}	n_{1N}	rpm	2300	2500	2800	2800	2800	3500	3500	3500	3500	3500	3500	3800	4500	4500				
Max. continuous speed (with 20% T_{2N} and 20°C ambient temperature)	n_{1Ncym}	rpm	3000	3500	4000	3500	3500	4500	4500	4500	4500	4500	4500	4500	4500	4500				
Max. input speed	n_{1Max}	rpm	6000	6000	6000	6000	6000	6000	6000	6000	6000	6000	6000	6000	6000	6000				
Mean no load running torque (with $n_1=3000$ rpm and 20°C gearhead temperature) ^{d)}	T_{012}	Nm	2.0	1.7	1.5	2.0	1.8	0.3	0.3	0.2	0.2	0.2	0.2	0.1	0.1	0.1				
		in.lb	18	15	13	18	16	2.7	2.7	1.8	1.8	1.8	1.8	0.9	0.9	0.9				
Max. torsional backlash	j_t	arcmin	≤ 4																	
Torsional rigidity	C_{t21}	Nm/ arcmin	5.0	5.5	6.0	6.0	6.0	5.5	5.5	5.5	5.5	5.5	5.5	5.5	6.0	6.0	6.0			
		in.lb/ arcmin	44	49	53	53	53	49	49	49	49	49	49	49	53	53	53			
Max. axial force ^{e)}	F_{2AMax}	N	3400																	
		lb _f	765																	
Max. radial force ^{e)}	F_{2RMax}	N	4000																	
		lb _f	900																	
Max. tilting moment	M_{2KMax}	Nm	437																	
		in.lb	3867																	
Efficiency at full load	η	%	96					94												
Service life (For calculation, see the Chapter "Information")	L_h	h	> 20000																	
Weight incl. standard adapter plate	<i>m</i>	kg	4.8					5.4												
		lb _m	10.6					11.9												
Operating noise (with $n_1=3000$ rpm no load)	L_{PA}	dB(A)	≤ 66																	
Max. permitted housing temperature		°C	+90																	
		F	194																	
Ambient temperature		°C	0 to +40																	
		F	32 to 104																	
Lubrication			Lubricated for life																	
Paint			Blue RAL 5002																	
Direction of rotation			Motor and gearhead opposite directions																	
Protection class			IP 65																	
Moment of inertia (relates to the drive) Clamping hub diameter [mm]	C	14	J_t	kgcm ²	-	-	-	-	-	0.28	0.27	0.23	0.23	0.20	0.20	0.18	0.18	0.18	0.18	
				10 ⁻³ in.lb.in. ²	-	-	-	-	-	0.25	0.24	0.21	0.20	0.18	0.18	0.16	0.16	0.16	0.16	
	E	19	J_t	kgcm ²	1.46	1.19	1.06	0.95	0.90	0.73	0.71	0.68	0.67	0.63	0.62	0.63	0.63	0.63	0.63	0.63
				10 ⁻³ in.lb.in. ²	1.29	1.05	0.94	0.84	0.79	0.64	0.63	0.60	0.59	0.55	0.55	0.55	0.56	0.55	0.55	0.55
H	28	J_t	kgcm ²	2.88	2.61	2.47	2.37	2.31	-	-	-	-	-	-	-	-	-	-		
			10 ⁻³ in.lb.in. ²	2.55	2.31	2.19	2.10	2.04	-	-	-	-	-	-	-	-	-	-		

Please contact us for information on the best configuration for S1 conditions of use (continuous operation).

^{a)} Other ratios available on request

^{b)} Higher speeds are possible if the nominal torque is reduced

^{c)} For higher ambient temperatures, please reduce input speed

^{d)} Idling torques decrease during operation

^{e)} Refers to center of the output shaft or flange

All technical data for front output side applies.

Please request information for rear output side versions.

View A

1-stage:

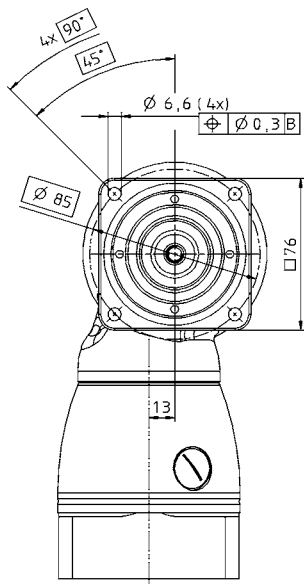

← A

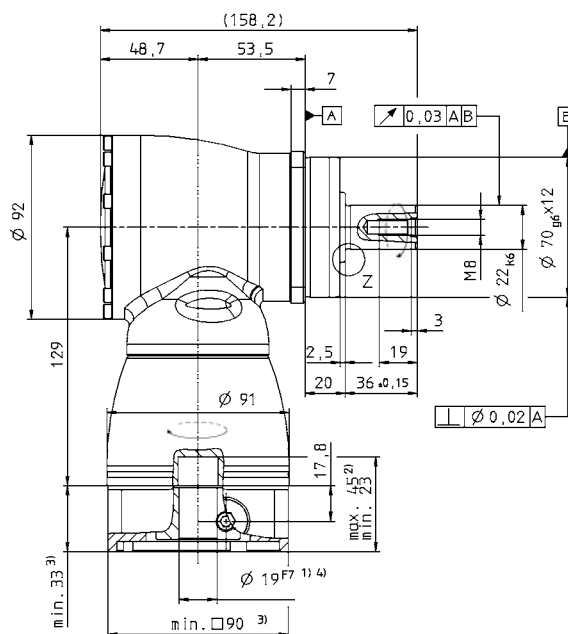

2-stage:

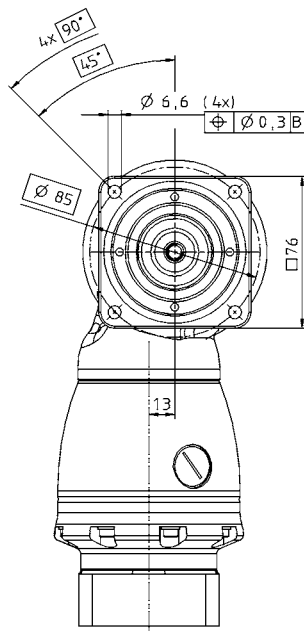

← A

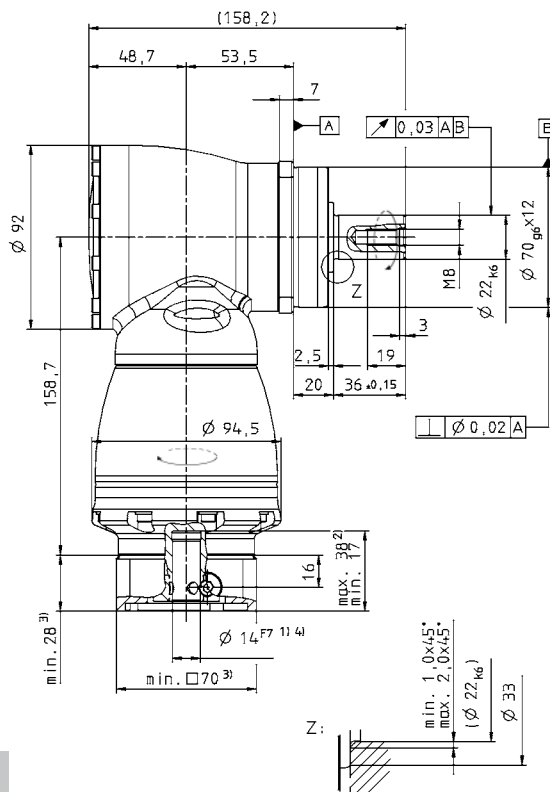

Alternatives: Output shaft variants

Keywayed output shaft in mm
E = key as per DIN 6885, sheet 1, form A

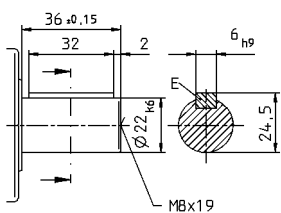

Involute gearing DIN 5480 in mm
X = W 22 x 1.25 x 30 x 16 x 6m

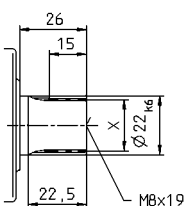

See technical data sheet for available clamping hub diameters (mass moment of inertia). Dimensions available on request.

Non-tolerated dimensions ±1 mm

- 1) Check motor shaft fit.
- 2) Min./Max. permissible motor shaft length. Longer motor shafts are adaptable, please contact us.
- 3) The dimensions depend on the motor.
- 4) Smaller motor shaft diameter is compensated by a bushing with a minimum thickness of 1 mm.

⚠ Motor mounting according to operating manual



SK+ 100 MF 1/2-stage

		1-stage					2-stage													
Ratio ^{a)}	<i>i</i>	3	4	5	7	10	12	16	20	25	28	35	40	50	70	100				
Max. acceleration torque (max. 1000 cycles per hour)	T_{2B}	Nm	170	170	170	145	125	170	170	170	170	170	170	170	145	125				
		in.lb	1505	1505	1505	1283	1106	1505	1505	1505	1505	1505	1505	1505	1283	1106				
Nominal output torque (with n_{1N})	T_{2N}	Nm	100	100	100	90	80	100	100	100	100	100	100	100	90	80				
		in.lb	885	885	885	797	708	885	885	885	885	885	885	885	797	708				
Emergency stop torque (permitted 1000 times during the service life of the gearhead)	T_{2Not}	Nm	220	260	260	255	250	260	260	260	260	260	260	260	255	250				
		in.lb	1947	2301	2301	2257	2213	2301	2301	2301	2301	2301	2301	2301	2257	2213				
Nominal input speed (with T_{2N} and 20°C ambient temperature) ^{b), c)}	n_{1N}	rpm	2200	2400	2700	2500	2500	3100	3100	3100	3100	3100	3100	3500	4200	4200				
Max. continuous speed (with 20% T_{2N} and 20°C ambient temperature)	n_{1Ncym}	rpm	3000	3400	3800	3400	3400	4000	4000	4000	4000	4000	4000	4000	4200	4200				
Max. input speed	n_{1Max}	rpm	4500	4500	4500	4500	4500	4500	4500	4500	4500	4500	4500	4500	4500	4500				
Mean no load running torque (with $n_1=3000$ rpm and 20°C gearhead temperature) ^{d)}	T_{012}	Nm	3.8	3.0	2.3	3.5	2.8	0.6	0.6	0.5	0.4	0.4	0.3	0.2	0.2	0.2				
		in.lb	34	27	20	31	25	5.3	5.3	4.4	3.5	3.5	2.7	1.8	1.8	1.8				
Max. torsional backlash	j_i	arcmin	≤ 4																	
Torsional rigidity	C_{i21}	Nm/arcmin	10	11	13	13	13	11	11	11	11	11	11	11	13	13	13			
		in.lb/arcmin	89	97	115	115	115	97	97	97	97	97	97	97	115	115	115			
Max. axial force ^{e)}	F_{2AMax}	N	5700																	
		lb _f	1283																	
Max. radial force ^{e)}	F_{2RMax}	N	6300																	
		lb _f	1418																	
Max. tilting moment	M_{2KMax}	Nm	833																	
		in.lb	7370																	
Efficiency at full load	η	%	96					94												
Service life (For calculation, see the Chapter "Information")	L_h	h	> 20000																	
Weight incl. standard adapter plate	<i>m</i>	kg	9.3					10.0												
		lb _m	21					22												
Operating noise (with $n_1=3000$ rpm no load)	L_{PA}	dB(A)	≤ 66																	
Max. permitted housing temperature		°C	+90																	
		F	194																	
Ambient temperature		°C	0 to +40																	
		F	32 to 104																	
Lubrication			Lubricated for life																	
Paint			Blue RAL 5002																	
Direction of rotation			Motor and gearhead opposite directions																	
Protection class			IP 65																	
Moment of inertia (relates to the drive) Clamping hub diameter [mm]	E	19	J_1	kgcm ²	-	-	-	-	-	1.02	0.97	0.86	0.84	0.75	0.74	0.69	0.69	0.68	0.68	
				10 ⁻³ in.lb.s ²	-	-	-	-	-	0.91	0.86	0.76	0.74	0.66	0.66	0.61	0.61	0.60	0.60	
	G	24	J_1	kgcm ²	-	-	-	-	-	2.59	2.54	2.42	2.40	2.31	2.30	2.26	2.25	2.25	2.25	2.25
				10 ⁻³ in.lb.s ²	-	-	-	-	-	2.29	2.25	2.14	2.13	2.05	2.04	2.00	1.99	1.99	1.99	
	H	28	J_1	kgcm ²	4.64	3.80	3.34	2.98	2.79	-	-	-	-	-	-	-	-	-	-	-
				10 ⁻³ in.lb.s ²	4.10	3.36	2.95	2.64	2.47	-	-	-	-	-	-	-	-	-	-	-
	K	38	J_1	kgcm ²	11.9	11.0	10.6	10.2	10.0	-	-	-	-	-	-	-	-	-	-	-
				10 ⁻³ in.lb.s ²	10.5	9.77	9.37	9.05	8.89	-	-	-	-	-	-	-	-	-	-	-

Please contact us for information on the best configuration for S1 conditions of use (continuous operation).

^{a)} Other ratios available on request

^{b)} Higher speeds are possible if the nominal torque is reduced

^{c)} For higher ambient temperatures, please reduce input speed

^{d)} Idling torques decrease during operation

^{e)} Refers to center of the output shaft or flange

All technical data for front output side applies.

Please request information for rear output side versions.

1-stage:

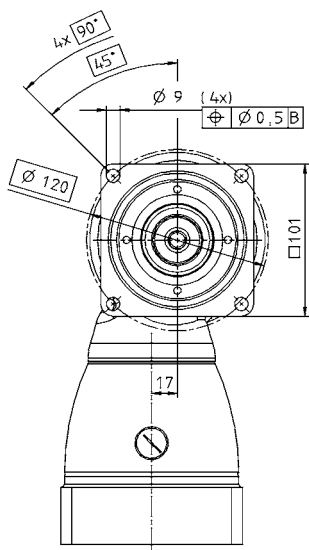

← A

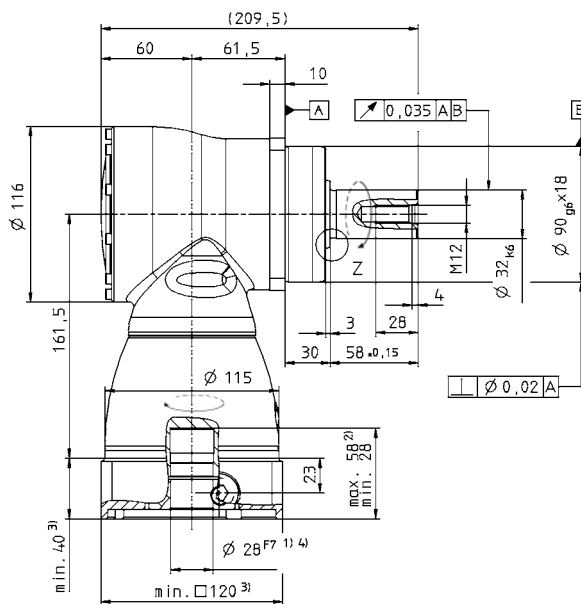

2-stage:

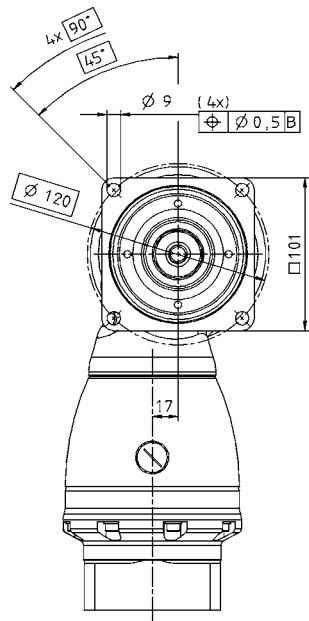

← A

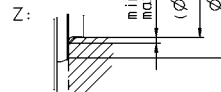
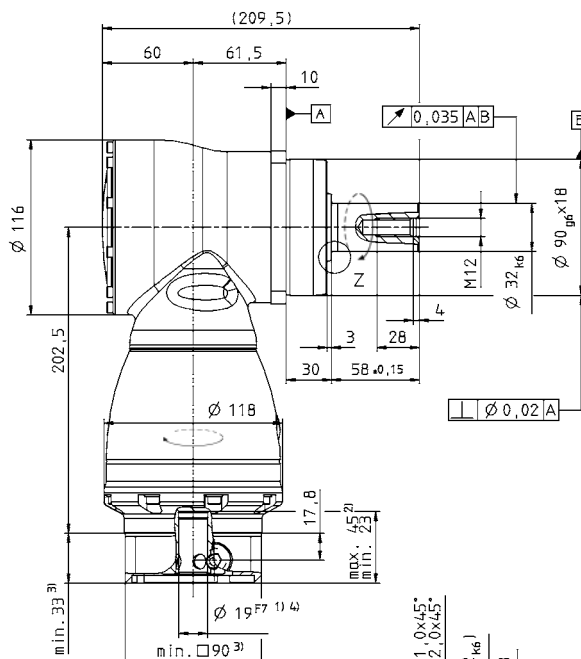

Alternatives: Output shaft variants

Keywayed output shaft in mm
E = key as per DIN 6885, sheet 1, form A

Involute gearing DIN 5480
X = W 32 x 1.25 x 30 x 24 x 6 mm

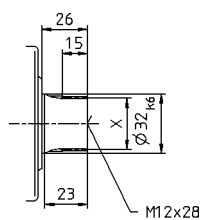
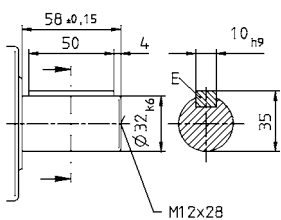

See technical data sheet for available clamping hub diameters (mass moment of inertia). Dimensions available on request.

Non-tolerated dimensions ±1 mm

- 1) Check motor shaft fit.
- 2) Min./Max. permissible motor shaft length. Longer motor shafts are adaptable, please contact us.
- 3) The dimensions depend on the motor.
- 4) Smaller motor shaft diameter is compensated by a bushing with a minimum thickness of 1 mm.

⚠ Motor mounting according to operating manual



SK+ 140 MF 1/2-stage

		1-stage					2-stage												
Ratio ^{a)}	<i>i</i>	3	4	5	7	10	12	16	20	25	28	35	40	50	70	100			
Max. acceleration torque (max. 1000 cycles per hour)	T_{2B}	Nm	300	300	300	250	210	300	300	300	300	300	300	300	300	250	210		
		in.lb	2655	2655	2655	2213	1859	2655	2655	2655	2655	2655	2655	2655	2655	2213	1859		
Nominal output torque (with n_{1N})	T_{2N}	Nm	190	190	190	175	160	190	190	190	190	190	190	190	190	175	160		
		in.lb	1682	1682	1682	1549	1416	1682	1682	1682	1682	1682	1682	1682	1682	1549	1419		
Emergency stop torque (permitted 1000 times during the service life of the gearhead)	T_{2Not}	Nm	400	500	500	450	400	500	500	500	500	500	500	500	500	450	400		
		in.lb	3540	4425	4425	3983	3540	4425	4425	4425	4425	4425	4425	4425	4425	3983	3540		
Nominal input speed (with T_{2N} and 20°C ambient temperature) ^{b), c)}	n_{1N}	rpm	1900	2000	2200	2000	2000	2900	2900	2900	2900	2900	2900	2900	3200	3200	3900		
Max. continuous speed (with 20% T_{2N} and 20°C ambient temperature)	n_{1Nocym}	rpm	2500	2800	3100	2800	2800	4000	4000	4000	4000	4000	4000	4000	4200	4200	4200		
Max. input speed	n_{1Max}	rpm	4500	4500	4500	4500	4500	4500	4500	4500	4500	4500	4500	4500	4500	4500	4500		
Mean no load running torque (with $n_1=3000$ rpm and 20°C gearhead temperature) ^{d)}	T_{012}	Nm	7.0	5.2	4.5	7.5	5.5	1.4	0.9	0.7	0.5	0.5	0.4	0.4	0.3	0.3	0.3		
		in.lb	62	46	40	66	49	12.4	8	6.2	4.4	4.4	3.5	3.5	2.7	2.7	2.7		
Max. torsional backlash	j_i	arcmin	≤ 4																
Torsional rigidity	C_{i21}	Nm/ arcmin	27	30	32	32	32	29	29	29	29	29	29	29	31	31	31		
		in.lb/ arcmin	239	266	283	283	283	257	257	257	257	257	257	257	274	274	274		
Max. axial force ^{e)}	F_{2AMax}	N	9900																
		lb _f	2228																
Max. radial force ^{e)}	F_{2RMax}	N	9500																
		lb _f	2138																
Max. tilting moment	M_{2KMax}	Nm	1692																
		in.lb	14974																
Efficiency at full load	η	%	96					94											
Service life (For calculation, see the Chapter "Information")	L_h	h	> 20000																
Weight incl. standard adapter plate	<i>m</i>	kg	22.6					25.0											
		lb _m	50					55											
Operating noise (with $n_1=3000$ rpm without load)	L_{PA}	dB(A)	≤ 68																
Max. permitted housing temperature		°C	+90																
		F	194																
Ambient temperature		°C	0 to +40																
		F	32 to 104																
Lubrication			Lubricated for life																
Paint			Blue RAL 5002																
Direction of rotation			Motor and gearhead opposite directions																
Protection class			IP 65																
Moment of inertia (relates to the drive) Clamping hub diameter [mm]	G	24	J_1	kgcm ²	-	-	-	-	-	4.21	3.85	3.28	3.17	2.78	2.73	2.48	2.46	2.43	2.42
				10 ⁻³ in.lb.in ²	-	-	-	-	-	3.73	3.41	2.90	2.80	2.46	2.41	2.20	2.17	2.15	2.14
	K	38	J_1	kgcm ²	25.0	19.1	16.3	14.1	12.8	11.1	10.7	10.2	10.1	9.69	9.64	9.39	9.37	9.34	9.33
				10 ⁻³ in.lb.in ²	22.1	16.9	14.4	12.4	11.3	9.83	9.51	9.01	8.92	8.58	8.53	8.31	8.29	8.27	8.26

^{a)} Other ratios available on request

^{b)} Higher speeds are possible if the nominal torque is reduced

^{c)} For higher ambient temperatures, please reduce input speed

^{d)} Idling torques decrease during operation

^{e)} Refers to center of the output shaft or flange

All technical data for front output side applies.

Please request information for rear output side versions.

Please contact us for information on the best configuration for S1 conditions of use (continuous operation).

View A

1-stage:

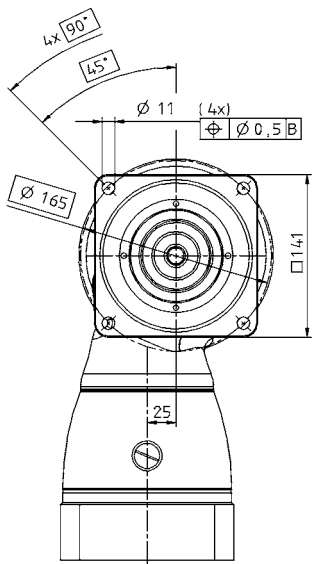

← A

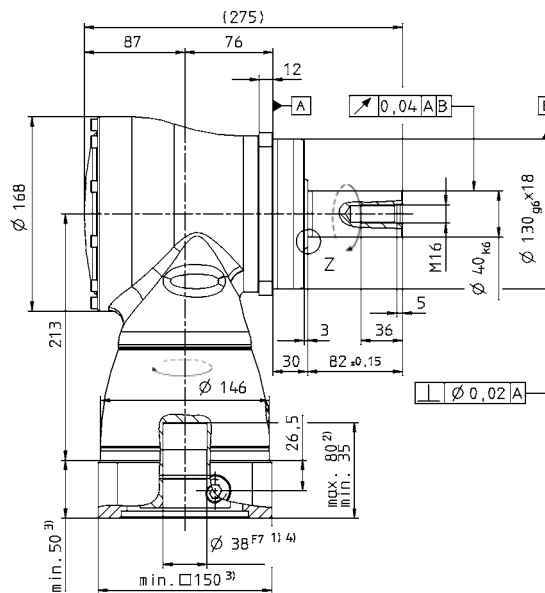

2-stage:

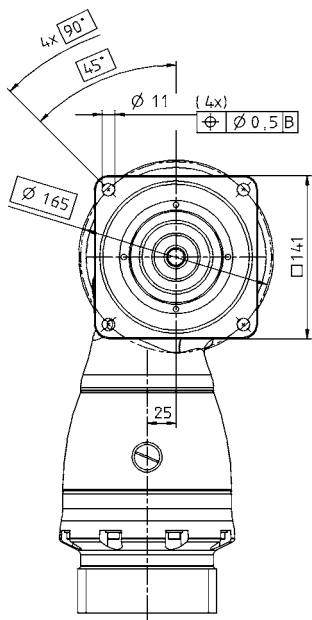

← A

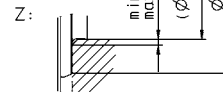
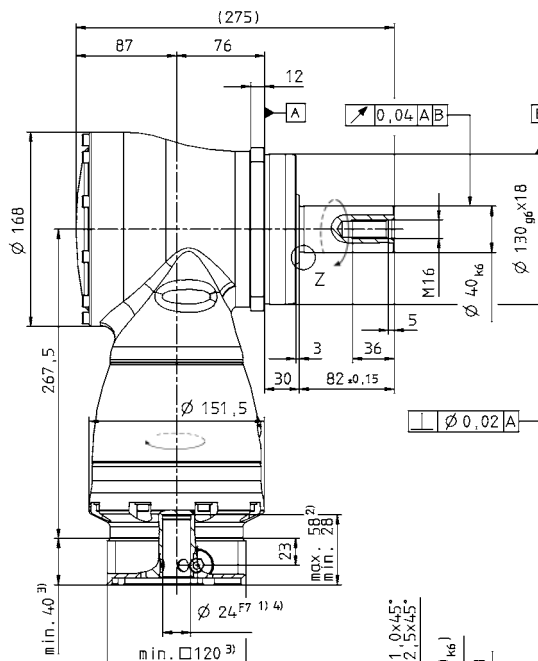

Alternatives: Output shaft variants

Keywayed output shaft in mm
E = key as per DIN 6885, sheet 1, form A

Involute gearing DIN 5480
X = W 40 x 2 x 30 x 18 x 6 m

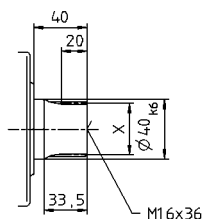
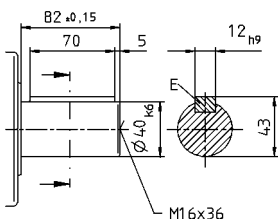

See technical data sheet for available clamping hub diameters (mass moment of inertia). Dimensions available on request.

Non-tolerated dimensions ±1 mm

- 1) Check motor shaft fit.
- 2) Min./Max. permissible motor shaft length. Longer motor shafts are adaptable, please contact us.
- 3) The dimensions depend on the motor.
- 4) Smaller motor shaft diameter is compensated by a bushing with a minimum thickness of 1 mm.

⚠ Motor mounting according to operating manual



SK+ 180 MF 1/2-stage

		1-stage					2-stage												
Ratio ^{a)}	<i>i</i>	3	4	5	7	10	12	16	20	25	28	35	40	50	70	100			
Max. acceleration torque (max. 1000 cycles per hour)	T_{2B}	Nm	640	640	640	550	470	640	640	640	640	640	640	640	550	470			
		in.lb	5664	5664	5664	4868	4160	5664	5664	5664	5664	5664	5664	5664	4868	4160			
Nominal output torque (with n_{1N})	T_{2N}	Nm	400	400	400	380	360	400	400	400	400	400	400	400	380	360			
		in.lb	3540	3540	3540	3363	3186	3540	3540	3540	3540	3540	3540	3540	3363	3186			
Emergency stop torque (permitted 1000 times during the service life of the gearhead)	T_{2Not}	Nm	900	1050	1050	970	900	1050	1050	1050	1050	1050	1050	1050	970	900			
		in.lb	7965	9293	9293	8585	7965	9293	9293	9293	9293	9293	9293	9293	8585	7965			
Nominal input speed (with T_{2N} and 20°C ambient temperature) ^{b), c)}	n_{1N}	rpm	1600	1800	2000	1800	1800	2700	2700	2700	2700	2700	2700	2900	3200	3400			
Max. continuous speed (with 20% T_{2N} and 20°C ambient temperature)	n_{1Nocym}	rpm	2000	2400	2800	2500	2500	3500	3500	3500	3500	3500	3500	3500	3800	3800			
Max. input speed	n_{1Max}	rpm	4000	4000	4000	4000	4000	4000	4000	4000	4000	4000	4000	4000	4000	4000			
Mean no load running torque (with $n_1=3000$ rpm and 20°C gearhead temperature) ^{d)}	T_{012}	Nm	14.5	12.0	10.0	15.0	12.5	3.0	2.3	1.8	1.6	1.3	1.2	0.9	0.9	0.9			
		in.lb	128	106	89	133	111	26.6	20.4	15.9	14.2	11.5	10.6	8.0	8.0	8.0			
Max. torsional backlash	j_i	arcmin	≤ 4																
Torsional rigidity	C_{i21}	Nm/ arcmin	64	71	79	78	77	71	71	71	71	71	71	71	78	78	78		
		in.lb/ arcmin	566	628	699	690	681	628	628	628	628	628	628	628	690	690	690		
Max. axial force ^{e)}	F_{2AMax}	N	14200																
		lb _f	3195																
Max. radial force ^{e)}	F_{2RMax}	N	14700																
		lb _f	3308																
Max. tilting moment	M_{2KMax}	Nm	3213																
		in.lb	28435																
Efficiency at full load	η	%	96					94											
Service life (For calculation, see the Chapter "Information")	L_h	h	> 20000																
Weight incl. standard adapter plate	<i>m</i>	kg	45.4					48											
		lb _m	100					106											
Operating noise (with $n_1=3000$ rpm no load)	L_{PA}	dB(A)	≤ 68																
Max. permitted housing temperature		°C	+90																
		F	194																
Ambient temperature		°C	0 to +40																
		F	32 to 104																
Lubrication			Lubricated for life																
Paint			Blue RAL 5002																
Direction of rotation			Motor and gearhead opposite directions																
Protection class			IP 65																
Moment of inertia (relates to the drive) Clamping hub diameter [mm]	K	38	J_1	kgcm ²	-	-	-	-	-	15.3	14.0	12.3	12.0	10.9	10.7	10.1	10.0	9.95	9.91
				10 ⁻³ in.lb.s ²	-	-	-	-	-	13.6	12.3	10.9	10.6	9.65	9.48	8.96	8.88	8.81	8.77
	M	48	J_1	kgcm ²	73.3	51.6	42.1	34.0	29.7	30.0	28.7	27.1	26.7	25.6	25.4	24.8	24.7	24.7	24.6
				10 ⁻³ in.lb.s ²	64.9	45.6	37.3	30.1	26.3	26.6	25.4	23.9	23.6	22.7	22.5	22.0	21.9	21.8	21.8

^{a)} Other ratios available on request

^{b)} Higher speeds are possible if the nominal torque is reduced

^{c)} For higher ambient temperatures, please reduce input speed

^{d)} Idling torques decrease during operation

^{e)} Refers to center of the output shaft or flange

All technical data for front output side applies.

Please request information for rear output side versions.

Please contact us for information on the best configuration for S1 conditions of use (continuous operation).

1-stage:

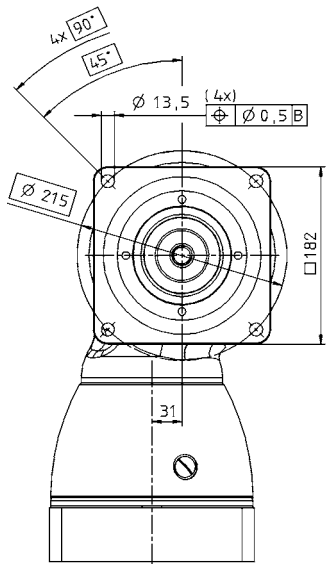

← A

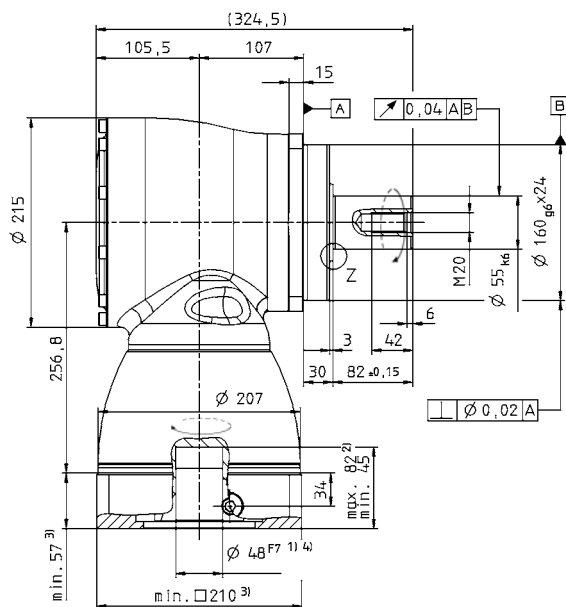

2-stage:

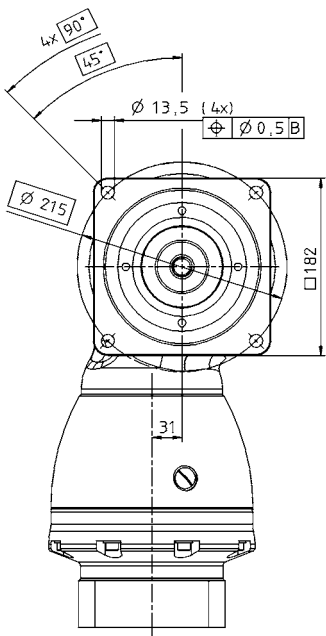

← A

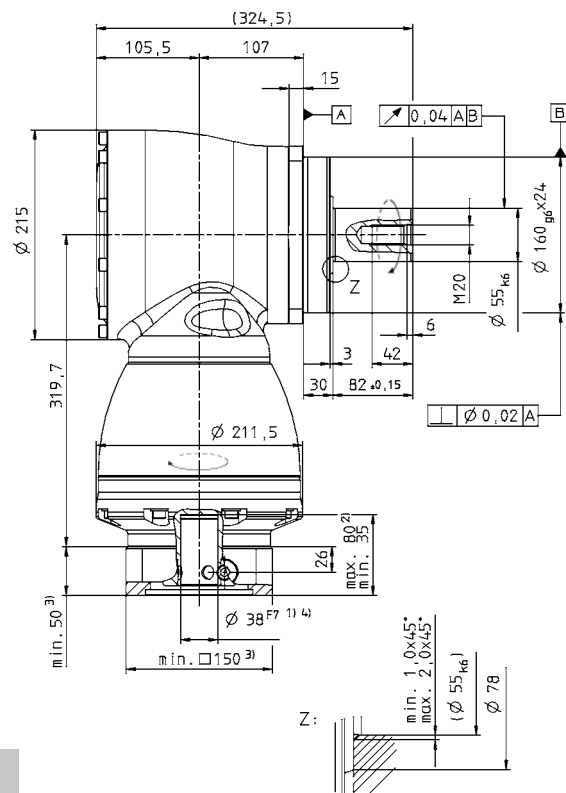

Alternatives: Output shaft variants

Keywayed output shaft in mm
E = key as per DIN 6885, sheet 1, form A

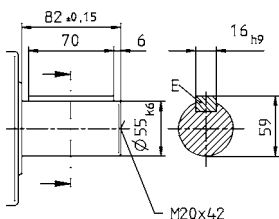

Involute gearing DIN 5480
X = W 55 x 2 x 30 x 26 x 6 mm

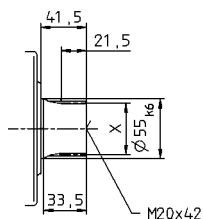

See technical data sheet for available clamping hub diameters (mass moment of inertia). Dimensions available on request.

Non-tolerated dimensions ±1 mm

- 1) Check motor shaft fit.
- 2) Min./Max. permissible motor shaft length. Longer motor shafts are adaptable, please contact us.
- 3) The dimensions depend on the motor.
- 4) Smaller motor shaft diameter is compensated by a bushing with a minimum thickness of 1 mm.

⚠ Motor mounting according to operating manual



SPK+ 075 MF 2-stage

		2-stage												
Ratio ^{a)}	<i>i</i>		12	16	20	25	28	35	40	50	70	100		
Max. acceleration torque (max. 1000 cycles per hour)	T_{2B}	Nm	110	110	110	110	110	110	80	100	110	90		
		in.lb	974	974	974	974	974	974	974	885	974	797		
Nominal output torque (with n_{1N})	T_{2N}	Nm	75	75	75	75	75	75	60	75	75	52		
		in.lb	664	664	664	664	664	664	531	664	664	460		
Emergency stop torque (permitted 1000 times during the service life of the gearhead)	T_{2Not}	Nm	160	160	200	200	250	175	120	150	210	200		
		in.lb	1416	1416	1770	1770	2213	1549	1062	1328	1859	1770		
Nominal input speed (with T_{2N} and 20°C ambient temperature) ^{b), c)}	n_{1N}	rpm	2000	2400	2400	2700	2400	2500	2500	2500	2500	2500		
Max. continuous speed (with 20% T_{2N} and 20°C ambient temperature)	n_{1Ncym}	rpm	3000	3400	3400	3800	3400	3200	3200	3200	3200	3200		
Max. input speed	n_{1Max}	rpm	6000	6000	6000	6000	6000	6000	6000	6000	6000	6000		
Mean no load running torque (with $n_1=3000$ rpm and 20°C gearhead temperature) ^{d)}	T_{012}	Nm	1.5	1.3	1.2	1.2	1.2	1.3	1.3	1.3	1.3	1.3		
		in.lb	13.3	11.5	10.6	10.6	10.6	11.5	11.5	11.5	11.5	11.5		
Max. torsional backlash	j_t	arcmin	Standard ≤ 5 / Reduced ≤ 3											
Torsional rigidity	C_{t21}	Nm/ arcmin	10											
		in.lb/ arcmin	89											
Max. axial force ^{e)}	F_{2AMax}	N	3350											
		lb _f	753											
Max. radial force ^{e)}	F_{2RMax}	N	4000											
		lb _f	900											
Max. tilting moment	M_{2KMax}	Nm	236											
		in.lb	2089											
Efficiency at full load	η	%	94											
Service life (For calculation, see the Chapter "Information")	L_h	h	> 20000											
Weight incl. standard adapter plate	<i>m</i>	kg	5.2											
		lb _m	11.5											
Operating noise (with $n_1=3000$ rpm no load)	L_{PA}	dB(A)	≤ 66											
Max. permitted housing temperature		°C	+90											
		F	194											
Ambient temperature		°C	0 to +40											
		F	32 to 104											
Lubrication			Lubricated for life											
Paint			Blue RAL 5002											
Direction of rotation			Motor and gearhead opposite directions											
Protection class			IP 65											
Moment of inertia (relates to the drive) Clamping hub diameter [mm]	C	14	J_1	kgcm ²	0.54	0.45	0.44	0.40	0.44	0.36	0.35	0.34	0.34	0.34
				10 ⁻³ in.lb.s ²	0.48	0.40	0.39	0.35	0.39	0.32	0.31	0.30	0.30	0.30
	E	19	J_1	kgcm ²	0.89	0.80	0.79	0.75	0.79	0.71	0.70	0.70	0.70	0.69
				10 ⁻³ in.lb.s ²	0.79	0.71	0.70	0.66	0.70	0.63	0.62	0.62	0.62	0.61

^{a)} Other ratios up to $i=1000$ available on request

^{b)} Higher speeds are possible if the nominal torque is reduced

^{c)} For higher ambient temperatures, please reduce input speed

^{d)} Idling torques decrease during operation

^{e)} Refers to center of the output shaft or flange

All technical data for front output side applies.

Please request information for rear output side versions.

Please contact us for information on the best configuration for S1 conditions of use (continuous operation).

2-stage:

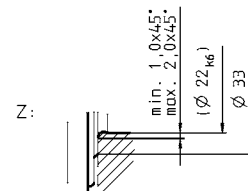
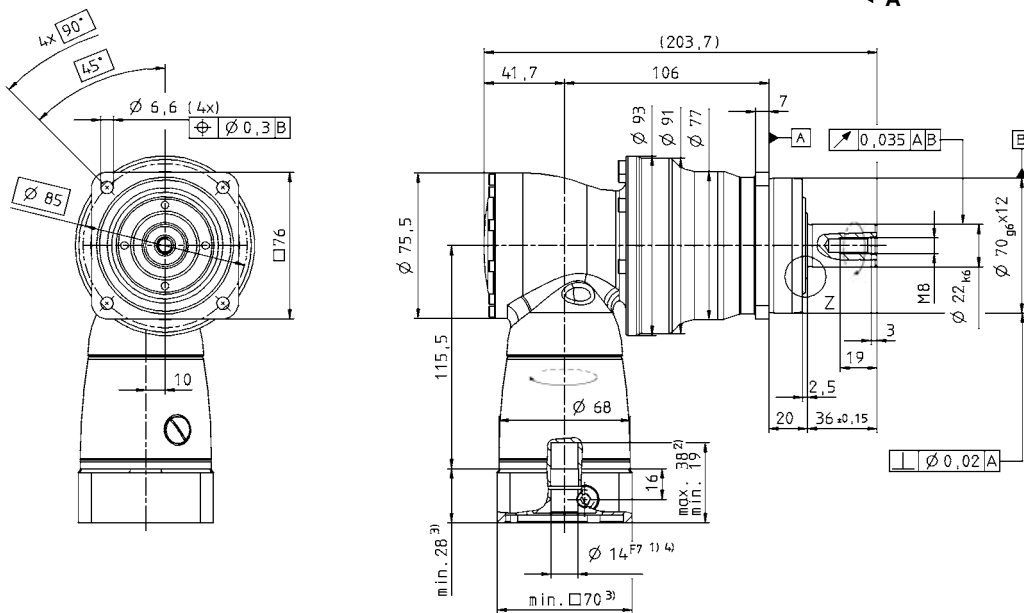

Alternatives: Output shaft variants

Keywayed output shaft in mm
E = key as per DIN 6885, sheet 1, form A

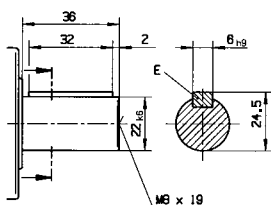

Involute gearing DIN 5480 in mm
X = W 22 x 1.25 x 30 x 16 x 6m, DIN 5480

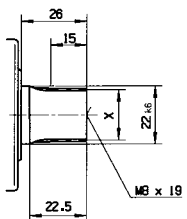

See technical data sheet for available clamping hub diameters (mass moment of inertia). Dimensions available on request.

Non-tolerated dimensions ± 1 mm

- 1) Check motor shaft fit.
- 2) Min./Max. permissible motor shaft length. Longer motor shafts are adaptable, please contact us.
- 3) The dimensions depend on the motor.
- 4) Smaller motor shaft diameter is compensated by a bushing with a minimum thickness of 1 mm.

⚠ Motor mounting according to operating manual



SPK+ 075 MF 3-stage

		3-stage															
Ratio ^{a)}	<i>i</i>		64	84	100	125	140	175	200	250	280	350	400	500	700	1000	
Max. acceleration torque (max. 1000 cycles per hour)	T_{2B}	Nm	110	110	110	110	110	110	110	110	110	110	80	100	110	90	
		in.lb	974	974	974	974	974	974	974	974	974	974	708	885	974	797	
Nominal output torque (with n_{1N})	T_{2N}	Nm	75	75	75	75	75	75	75	75	75	75	60	75	75	52	
		in.lb	664	664	664	664	664	664	664	664	664	664	531	664	664	460	
Emergency stop torque (permitted 1000 times during the service life of the gearhead)	T_{2Not}	Nm	160	160	200	200	200	200	200	200	250	175	120	150	210	200	
		in.lb	1416	1416	1770	1770	1770	1770	1770	1770	2213	1549	1062	1328	1859	1770	
Nominal input speed (with T_{2N} and 20°C ambient temperature) ^{b), c)}	n_{1N}	rpm	4400	4400	4400	4400	4400	4400	4400	4800	4400	4800	5500	5500	5500	5500	
Max. continuous speed (with 20% T_{2N} and 20°C ambient temperature)	n_{1Nocym}	rpm	5000	5000	5000	5000	5000	5000	5000	5000	5000	5000	5500	5500	5500	5500	
Max. input speed	n_{1Max}	rpm	6000	6000	6000	6000	6000	6000	6000	6000	6000	6000	6000	6000	6000	6000	
Mean no load running torque (with $n_1=3000$ rpm and 20°C gearhead temperature) ^{d)}	T_{012}	Nm	0.3	0.3	0.3	0.3	0.3	0.3	0.2	0.2	0.2	0.2	0.2	0.2	0.2	0.2	
		in.lb	2.7	2.7	2.7	2.7	2.7	2.7	1.8	1.8	1.8	1.8	1.8	1.8	1.8	1.8	
Max. torsional backlash	j_t	arcmin	Standard ≤ 5 / Reduced ≤ 3														
Torsional rigidity	C_{t21}	Nm/ arcmin	10														
		in.lb/ arcmin	89														
Max. axial force ^{e)}	F_{2AMax}	N	3350														
		lb _f	754														
Max. radial force ^{e)}	F_{2RMax}	N	4000														
		lb _f	900														
Max. tilting moment	M_{2KMax}	Nm	236														
		in.lb	2089														
Efficiency at full load	η	%	92														
Service life (For calculation, see the Chapter "Information")	L_h	h	> 20000														
Weight incl. standard adapter plate	<i>m</i>	kg	5.5														
		lb _m	12.2														
Operating noise (with $n_1=3000$ rpm no load)	L_{PA}	dB(A)	≤ 66														
Max. permitted housing temperature		°C	+90														
		F	194														
Ambient temperature		°C	0 to +40														
		F	32 to 104														
Lubrication			Lubricated for life														
Paint			Blue RAL 5002														
Direction of rotation			Motor and gearhead opposite directions														
Protection class			IP 65														
Moment of inertia (relates to the drive) Clamping hub diameter [mm]	B	11	J_1	kgcm ²	0.09	0.07	0.08	0.07	0.06	0.06	0.06	0.06	0.06	0.06	0.06	0.06	0.06
				10 ⁻³ in.lb.s ²	0.08	0.06	0.07	0.06	0.05	0.05	0.05	0.05	0.05	0.05	0.05	0.05	0.05
	C	14	J_1	kgcm ²	0.20	0.18	0.19	0.19	0.18	0.18	0.17	0.17	0.17	0.17	0.17	0.17	0.17
				10 ⁻³ in.lb.s ²	0.18	0.16	0.17	0.17	0.16	0.16	0.15	0.15	0.15	0.15	0.15	0.15	0.15

- ^{a)} Other ratios up to $i=1000$ available on request
- ^{b)} Higher speeds are possible if the nominal torque is reduced
- ^{c)} For higher ambient temperatures, please reduce input speed
- ^{d)} Idling torques decrease during operation
- ^{e)} Refers to center of the output shaft or flange

All technical data for front output side applies.
Please request information for rear output side versions.

Please contact us for information on the best configuration for S1 conditions of use (continuous operation).

3-stage:

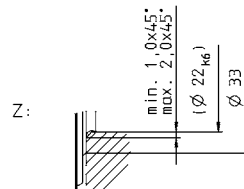
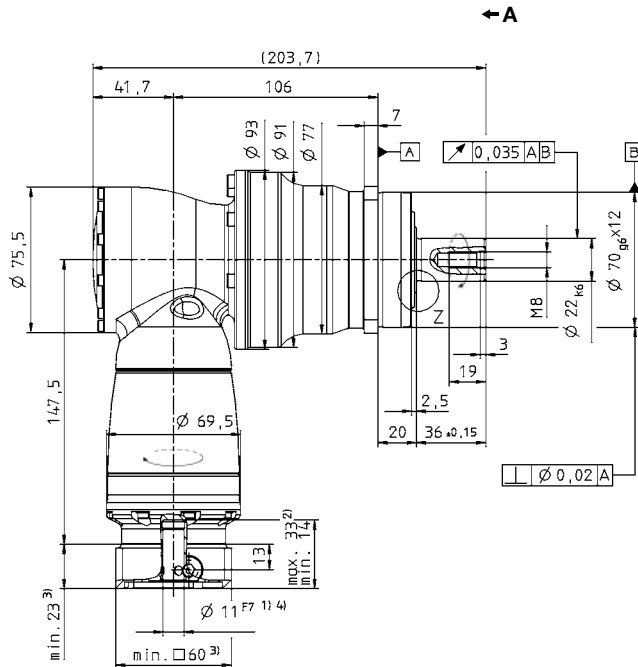
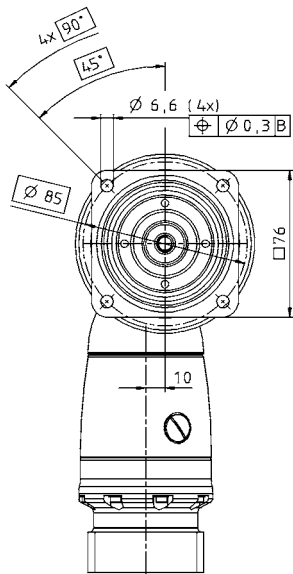

Alternatives: Output shaft variants

Keywayed output shaft in mm
E = key as per DIN 6885, sheet 1, form A

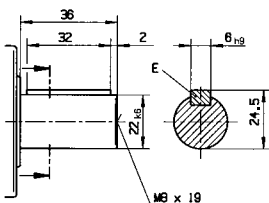

Involute gearing DIN 5480 in mm
X = W 22 x 1.25 x 30 x 16 x 6m, DIN 5480

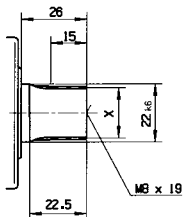

See technical data sheet for available clamping hub diameters (mass moment of inertia). Dimensions available on request.

Non-tolerated dimensions ±1 mm

- 1) Check motor shaft fit.
- 2) Min./Max. permissible motor shaft length. Longer motor shafts are adaptable, please contact us.
- 3) The dimensions depend on the motor.
- 4) Smaller motor shaft diameter is compensated by a bushing with a minimum thickness of 1 mm.

⚠ Motor mounting according to operating manual



SPK+ 100 MF 2-stage

		2-stage												
Ratio ^{a)}	<i>i</i>		12	16	20	25	28	35	40	50	70	100		
Max. acceleration torque (max. 1000 cycles per hour)	T_{2B}	Nm	280	280	300	300	300	300	200	250	300	225		
		in.lb	2478	2478	2655	2655	2655	2655	1770	2213	2655	1991		
Nominal output torque (with n_{1N})	T_{2N}	Nm	180	180	175	175	170	175	160	175	170	120		
		in.lb	1593	1593	1549	1549	1505	1549	1416	1549	1505	1062		
Emergency stop torque (permitted 1000 times during the service life of the gearhead)	T_{2Not}	Nm	400	400	500	500	625	500	400	500	625	500		
		in.lb	3540	3540	4425	4425	5531	4425	3540	4425	5531	4425		
Nominal input speed (with T_{2N} and 20°C ambient temperature) ^{b), c)}	n_{1N}	rpm	2000	2400	2400	2700	2400	2500	2500	2500	2500	2500		
Max. continuous speed (with 20% T_{2N} and 20°C ambient temperature)	n_{1Nocym}	rpm	3000	3400	3400	3800	3400	3200	3200	3200	3200	3200		
Max. input speed	n_{1Max}	rpm	6000	6000	6000	6000	6000	6000	6000	6000	6000	6000		
Mean no load running torque (with $n_1=3000$ rpm and 20°C gearhead temperature) ^{d)}	T_{012}	Nm	2.5	2.1	2.0	1.8	2.0	2.2	2.0	2.0	2.0	2.0		
		in.lb	22.1	18.6	17.7	15.9	17.7	19.5	17.7	17.7	17.7	17.7		
Max. torsional backlash	j_t	arcmin	Standard ≤ 4 / Reduced ≤ 2											
Torsional rigidity	C_{t21}	Nm/ arcmin	31											
		in.lb/ arcmin	274											
Max. axial force ^{e)}	F_{2AMax}	N	5650											
		lb _f	1271											
Max. radial force ^{e)}	F_{2RMax}	N	6300											
		lb _f	1418											
Max. tilting moment	M_{2KMax}	Nm	487											
		in.lb	4310											
Efficiency at full load	η	%	94											
Service life (For calculation, see the Chapter "Information")	L_h	h	> 20000											
Weight incl. standard adapter plate	<i>m</i>	kg	9.7											
		lb _m	21.4											
Operating noise (with $n_1=3000$ rpm no load)	L_{PA}	dB(A)	≤ 68											
Max. permitted housing temperature		°C	+90											
		F	194											
Ambient temperature		°C	0 to +40											
		F	32 to 104											
Lubrication	Lubricated for life													
Paint	Blue RAL 5002													
Direction of rotation	Motor and gearhead opposite directions													
Protection class	IP 65													
Moment of inertia (relates to the drive) Clamping hub diameter [mm]	E	19	J_1	kgcm ²	1.48	1.20	1.17	1.05	1.15	0.95	0.90	0.89	0.89	0.89
				10 ⁻³ in.lb.s ²	1.31	1.06	1.04	0.93	1.02	0.84	0.79	0.79	0.79	0.78
	H	28	J_1	kgcm ²	2.89	2.62	2.59	2.46	2.56	2.36	2.31	2.31	2.30	2.30
				10 ⁻³ in.lb.s ²	2.56	2.31	2.29	2.18	2.27	2.09	2.05	2.04	2.04	2.04

^{a)} Other ratios up to $i=1000$ available on request

^{b)} Higher speeds are possible if the nominal torque is reduced

^{c)} For higher ambient temperatures, please reduce input speed

^{d)} Idling torques decrease during operation

^{e)} Refers to center of the output shaft or flange

All technical data for front output side applies.

Please request information for rear output side versions.

Please contact us for information on the best configuration for S1 conditions of use (continuous operation).

2-stage:

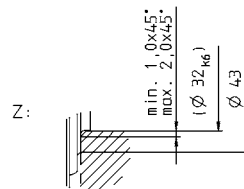
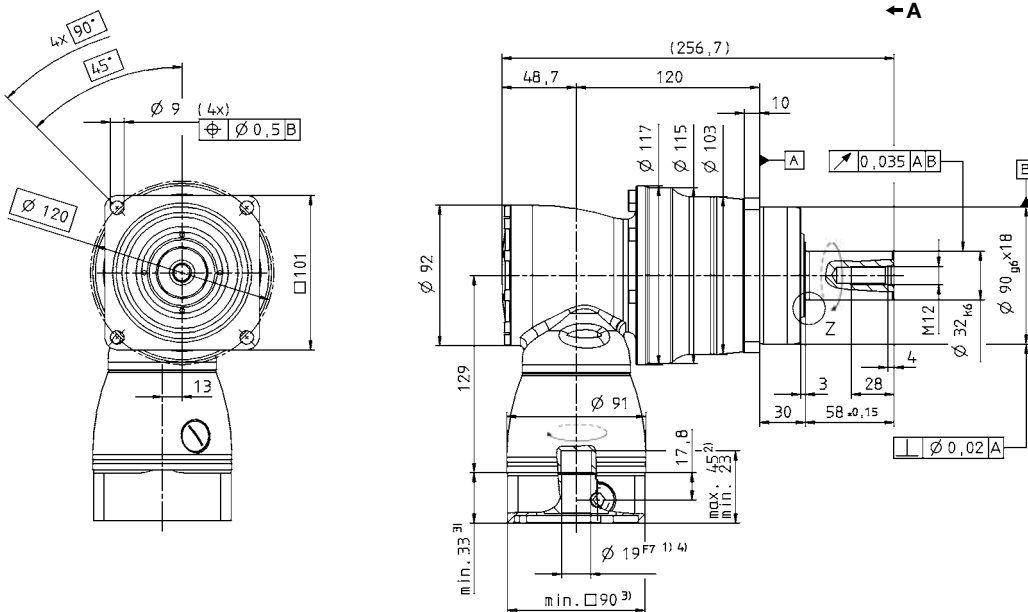

Alternatives: Output shaft variants

Keywayed output shaft in mm
E = key as per DIN 6885, sheet 1, form A

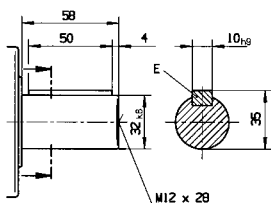

Involute gearing DIN 5480 in mm
X = W 32 x 1.25 x 30 x 24 x 6m, DIN 5480

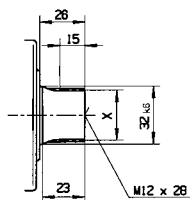

See technical data sheet for available clamping hub diameters (mass moment of inertia). Dimensions available on request.

Non-tolerated dimensions ± 1 mm

- 1) Check motor shaft fit.
- 2) Min./Max. permissible motor shaft length. Longer motor shafts are adaptable, please contact us.
- 3) The dimensions depend on the motor.
- 4) Smaller motor shaft diameter is compensated by a bushing with a minimum thickness of 1 mm.

⚠ Motor mounting according to operating manual

SPK+ 100 MF 3-stage

		3-stage															
Ratio ^{a)}	<i>i</i>		64	84	100	125	140	175	200	250	280	350	400	500	700	1000	
Max. acceleration torque (max. 1000 cycles per hour)	T_{2B}	Nm	280	280	300	300	300	300	300	300	300	300	200	250	300	225	
		in.lb	2478	2478	2655	2655	2655	2655	2655	2655	2655	2655	1770	2213	2655	1991	
Nominal output torque (with n_{1N})	T_{2N}	Nm	180	180	175	175	175	175	175	175	170	175	160	175	170	120	
		in.lb	1593	1593	1549	1549	1549	1549	1549	1549	1505	1549	1416	1549	1505	1062	
Emergency stop torque (permitted 1000 times during the service life of the gearhead)	T_{2Not}	Nm	400	400	500	500	500	500	500	500	625	500	400	500	625	500	
		in.lb	3540	3540	4425	4425	4425	4425	4425	4425	5531	4425	3540	4425	5531	4425	
Nominal input speed (with T_{2N} and 20°C ambient temperature) ^{b), c)}	n_{1N}	rpm	3500	3500	3500	3500	3500	3500	3500	3800	3500	3800	4500	4500	4500	4500	
Max. continuous speed (with 20% T_{2N} and 20°C ambient temperature)	n_{1Nocym}	rpm	4500	4500	4500	4500	4500	4500	4500	4500	4500	4500	4500	4500	4500	4500	
Max. input speed	n_{1Max}	rpm	6000	6000	6000	6000	6000	6000	6000	6000	6000	6000	6000	6000	6000	6000	
Mean no load running torque (with $n_1=3000$ rpm and 20°C gearhead temperature) ^{d)}	T_{012}	Nm	0.4	0.3	0.3	0.3	0.3	0.3	0.2	0.2	0.2	0.2	0.2	0.2	0.2	0.2	
		in.lb	3.5	2.7	2.7	2.7	2.7	2.7	1.8	1.8	1.8	1.8	1.8	1.8	1.8	1.8	
Max. torsional backlash	j_t	arcmin	Standard ≤ 4 / Reduced ≤ 2														
Torsional rigidity	C_{t21}	Nm/ arcmin	31														
		in.lb/ arcmin	274														
Max. axial force ^{e)}	F_{2AMax}	N	5650														
		lb _f	1271														
Max. radial force ^{e)}	F_{2RMax}	N	6300														
		lb _f	1418														
Max. tilting moment	M_{2KMax}	Nm	487														
		in.lb	4310														
Efficiency at full load	η	%	92														
Service life (For calculation, see the Chapter "Information")	L_h	h	> 20000														
Weight incl. standard adapter plate	<i>m</i>	kg	10.3														
		lb _m	22.8														
Operating noise (with $n_1=3000$ rpm no load)	L_{PA}	dB(A)	≤ 68														
Max. permitted housing temperature		°C	+90														
		F	194														
Ambient temperature		°C	0 to +40														
		F	32 to 104														
Lubrication			Lubricated for life														
Paint			Blue RAL 5002														
Direction of rotation			Motor and gearhead opposite directions														
Protection class			IP 65														
Moment of inertia (relates to the drive) Clamping hub diameter [mm]	C	14	J_1	kgcm ²	0.28	0.23	0.24	0.23	0.21	0.20	0.19	0.18	0.19	0.18	0.18	0.18	0.18
				10 ⁻³ in.lb.s ²	0.25	0.20	0.21	0.20	0.19	0.18	0.17	0.16	0.17	0.16	0.16	0.16	0.16
	E	19	J_1	kgcm ²	0.72	0.63	0.68	0.68	0.63	0.63	0.63	0.63	0.63	0.63	0.63	0.63	0.63
				10 ⁻³ in.lb.s ²	0.64	0.56	0.60	0.60	0.56	0.56	0.56	0.56	0.56	0.56	0.56	0.56	0.56

- ^{a)} Other ratios up to $i=1000$ available on request
- ^{b)} Higher speeds are possible if the nominal torque is reduced
- ^{c)} For higher ambient temperatures, please reduce input speed
- ^{d)} Idling torques decrease during operation
- ^{e)} Refers to center of the output shaft or flange

All technical data for front output side applies.
Please request information for rear output side versions.

Please contact us for information on the best configuration for S1 conditions of use (continuous operation).

3-stage:

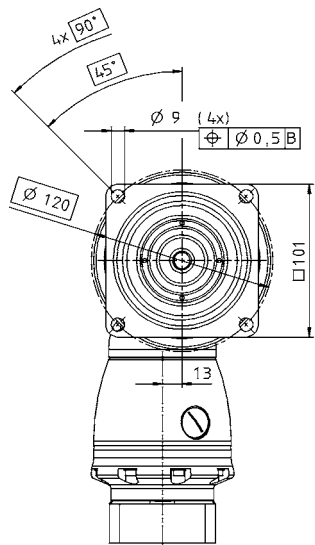

← A

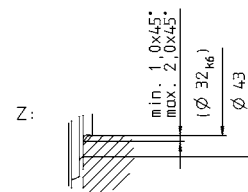
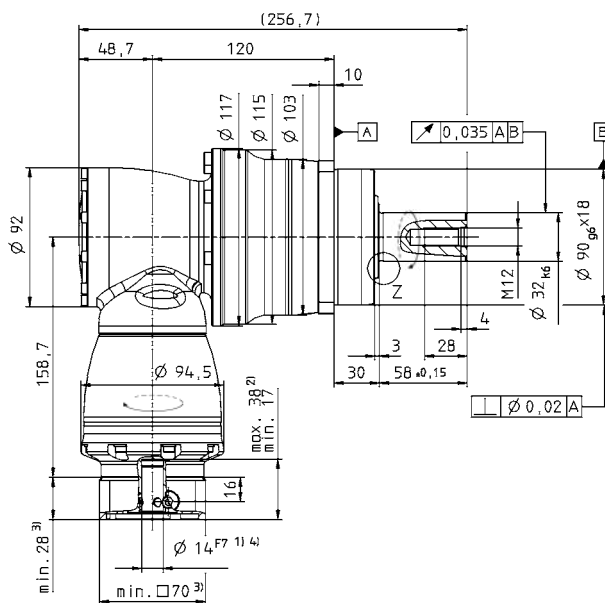

Alternatives: Output shaft variants

Keywayed output shaft in mm
E = key as per DIN 6885, sheet 1, form A

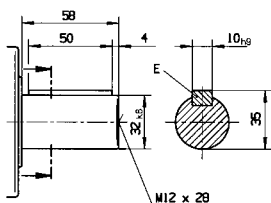

Involute gearing DIN 5480 in mm
X = W 32 x 1.25 x 30 x 24 x 6m, DIN 5480

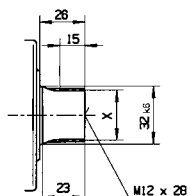

See technical data sheet for available clamping hub diameters (mass moment of inertia). Dimensions available on request.

Non-tolerated dimensions ±1 mm

- 1) Check motor shaft fit.
- 2) Min./Max. permissible motor shaft length. Longer motor shafts are adaptable, please contact us.
- 3) The dimensions depend on the motor.
- 4) Smaller motor shaft diameter is compensated by a bushing with a minimum thickness of 1 mm.

⚠ Motor mounting according to operating manual

SPK+ 140 MF 2-stage

		2-stage												
Ratio ^{a)}	<i>i</i>		12	16	20	25	28	35	40	50	70	100		
Max. acceleration torque (max. 1000 cycles per hour)	T_{2B}	Nm	600	600	600	600	600	600	500	600	600	480		
		in.lb	5310	5310	5310	5310	5310	5310	4425	5310	5310	4248		
Nominal output torque (with n_{1N})	T_{2N}	Nm	360	360	360	360	360	360	320	360	360	220		
		in.lb	3186	3186	3186	3186	3186	3186	2832	3186	3186	1947		
Emergency stop torque (permitted 1000 times during the service life of the gearhead)	T_{2Not}	Nm	1000	1000	1250	1250	1250	1250	1000	1250	1250	1000		
		in.lb	8850	8850	11063	11063	11063	11063	8850	11063	11063	8850		
Nominal input speed (with T_{2N} and 20°C ambient temperature) ^{b), c)}	n_{1N}	rpm	1900	2300	2300	2600	2300	2300	2300	2300	2300	2300		
Max. continuous speed (with 20% T_{2N} and 20°C ambient temperature)	n_{1Ncym}	rpm	2700	3100	3100	3500	3100	3000	3000	3000	3000	3000		
Max. input speed	n_{1Max}	rpm	4500	4500	4500	4500	4500	4500	4500	4500	4500	4500		
Mean no load running torque (with $n_1=3000$ rpm and 20°C gearhead temperature) ^{d)}	T_{012}	Nm	4.0	3.7	3.6	2.8	3.5	3.9	3.1	3.1	3.1	3.1		
		in.lb	35.4	32.7	31.9	24.8	31	34.5	27.4	27.4	27.4	27.4		
Max. torsional backlash	j_t	arcmin	Standard ≤ 4 / Reduced ≤ 2											
Torsional rigidity	C_{t21}	Nm/ arcmin	53											
		in.lb/ arcmin	469											
Max. axial force ^{e)}	F_{2AMax}	N	9870											
		lb _f	2221											
Max. radial force ^{e)}	F_{2RMax}	N	9450											
		lb _f	2126											
Max. tilting moment	M_{2KMax}	Nm	952											
		in.lb	8425											
Efficiency at full load	η	%	94											
Service life (For calculation, see the Chapter "Information")	L_h	h	> 20000											
Weight incl. standard adapter plate	<i>m</i>	kg	20											
		lb _m	44											
Operating noise (with $n_1=3000$ rpm no load)	L_{PA}	dB(A)	≤ 68											
Max. permitted housing temperature		°C	+90											
		F	194											
Ambient temperature		°C	0 to +40											
		F	32 to 104											
Lubrication	Lubricated for life													
Paint	Blue RAL 5002													
Direction of rotation	Motor and gearhead opposite directions													
Protection class	IP 65													
Moment of inertia (relates to the drive) Clamping hub diameter [mm]	H	28	J_1	kgcm ²	4.68	3.82	3.75	3.31	3.68	2.97	2.80	2.79	2.78	2.77
				10 ⁻³ in.lb.s ²	4.14	3.38	3.32	2.93	3.26	2.63	2.48	2.47	2.46	2.45
	K	38	J_1	kgcm ²	11.8	11.0	10.9	10.5	10.9	10.1	9.96	9.95	9.94	9.94
				10 ⁻³ in.lb.s ²	10.5	9.73	9.66	9.27	9.60	8.97	8.82	8.81	8.80	8.79

^{a)} Other ratios up to $i=1000$ available on request

^{b)} Higher speeds are possible if the nominal torque is reduced

^{c)} For higher ambient temperatures, please reduce input speed

^{d)} Idling torques decrease during operation

^{e)} Refers to center of the output shaft or flange

All technical data for front output side applies.

Please request information for rear output side versions.

Please contact us for information on the best configuration for S1 conditions of use (continuous operation).

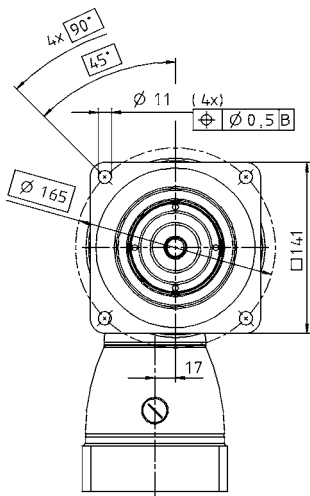
2-stage:

← A

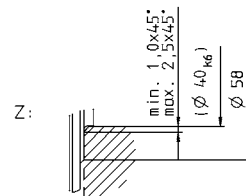
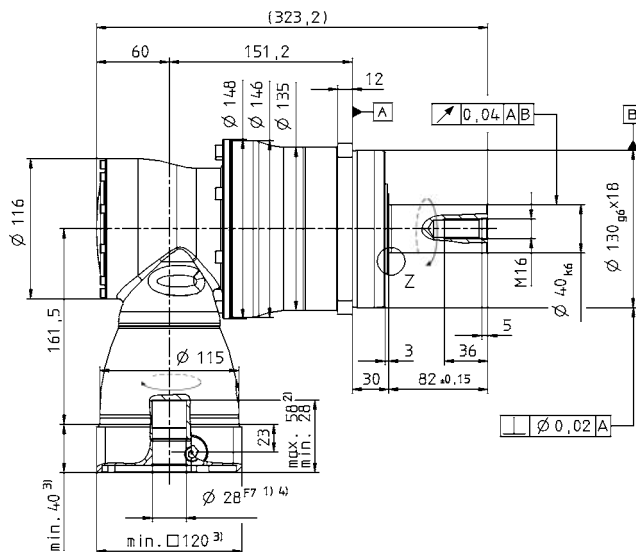
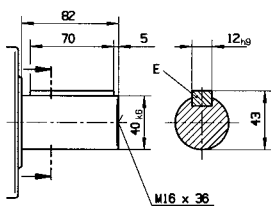
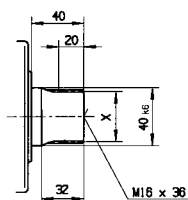
Alternatives: Output shaft variants
Keywayed output shaft in mm
 E = key as per DIN 6885, sheet 1, form A

Involute gearing DIN 5480 in mm
 X = W 40 x 2 x 30 x 18 x 6m, DIN 5480

See technical data sheet for available clamping hub diameters (mass moment of inertia). Dimensions available on request.

Non-tolerated dimensions ±1 mm

- 1) Check motor shaft fit.
- 2) Min./Max. permissible motor shaft length. Longer motor shafts are adaptable, please contact us.
- 3) The dimensions depend on the motor.
- 4) Smaller motor shaft diameter is compensated by a bushing with a minimum thickness of 1 mm.

Motor mounting according to operating manual

SPK+ 140 MF 3-stage

		3-stage															
Ratio ^{a)}	<i>i</i>		64	84	100	125	140	175	200	250	280	350	400	500	700	1000	
Max. acceleration torque (max. 1000 cycles per hour)	T_{2B}	Nm	600	600	600	600	600	600	600	600	600	600	500	600	600	480	
		in.lb	5310	5310	5310	5310	5310	5310	5310	5310	5310	5310	4425	5310	5310	4248	
Nominal output torque (with n_{1N})	T_{2N}	Nm	360	360	360	360	360	360	360	360	360	360	320	360	360	220	
		in.lb	3186	3186	3186	3186	3186	3186	3186	3186	3186	3186	2832	3186	3186	1947	
Emergency stop torque (permitted 1000 times during the service life of the gearhead)	T_{2Not}	Nm	1000	1000	1250	1250	1250	1250	1250	1250	1250	1250	1000	1250	1250	1000	
		in.lb	8850	8850	11063	11063	11063	11063	11063	11063	11063	11063	8850	11063	11063	8850	
Nominal input speed (with T_{2N} and 20°C ambient temperature) ^{b), c)}	n_{1N}	rpm	3100	3100	3100	3100	3100	3100	3100	3500	3100	3500	4200	4200	4200	4200	
Max. continuous speed (with 20% T_{2N} and 20°C ambient temperature)	n_{1Nocym}	rpm	4000	4000	4000	4000	4000	4000	4000	4000	4000	4000	4200	4200	4200	4200	
Max. input speed	n_{1Max}	rpm	4500	4500	4500	4500	4500	4500	4500	4500	4500	4500	4500	4500	4500	4500	
Mean no load running torque (with $n_1=3000$ rpm and 20°C gearhead temperature) ^{d)}	T_{012}	Nm	0.7	0.4	0.6	0.5	0.5	0.4	0.3	0.3	0.3	0.3	0.3	0.3	0.3	0.3	
		in.lb	6.2	3.5	5.3	4.4	4.4	3.5	2.7	2.7	2.7	2.7	2.7	2.7	2.7	2.7	
Max. torsional backlash	j_t	arcmin	Standard ≤ 4 / Reduced ≤ 2														
Torsional rigidity	C_{t21}	Nm/ arcmin	53														
		in.lb/ arcmin	469														
Max. axial force ^{e)}	F_{2AMax}	N	9870														
		lb _f	2221														
Max. radial force ^{e)}	F_{2RMax}	N	9450														
		lb _f	2126														
Max. tilting moment	M_{2KMax}	Nm	952														
		in.lb	8425														
Efficiency at full load	η	%	92														
Service life (For calculation, see the Chapter "Information")	L_h	h	> 20000														
Weight incl. standard adapter plate	m	kg	20.7														
		lb _m	45.7														
Operating noise (with $n_1=3000$ rpm no load)	L_{PA}	dB(A)	< 68														
Max. permitted housing temperature		°C	+90														
		F	194														
Ambient temperature		°C	0 to +40														
		F	32 to 104														
Lubrication	Lubricated for life																
Paint	Blue RAL 5002																
Direction of rotation	Motor and gearhead opposite directions																
Protection class	IP 65																
Moment of inertia (relates to the drive) Clamping hub diameter [mm]	E	19	J_1	kgcm ²	1.01	0.76	0.88	0.85	0.76	0.75	0.70	0.69	0.70	0.69	0.69	0.69	0.69
				10 ⁻³ in.lb.s ²	0.89	0.67	0.78	0.75	0.67	0.66	0.62	0.61	0.62	0.61	0.61	0.61	0.61
	G	24	J_1	kgcm ²	2.57	2.32	2.44	2.42	2.32	2.31	2.26	2.25	2.26	2.25	2.25	2.25	2.25
				10 ⁻³ in.lb.s ²	2.27	2.05	2.16	2.14	2.05	2.04	2.00	1.99	2.00	1.99	1.99	1.99	1.99

^{a)} Other ratios up to $i=1000$ available on request

^{b)} Higher speeds are possible if the nominal torque is reduced

^{c)} For higher ambient temperatures, please reduce input speed

^{d)} Idling torques decrease during operation

^{e)} Refers to center of the output shaft or flange

All technical data for front output side applies.

Please request information for rear output side versions.

Please contact us for information on the best configuration for S1 conditions of use (continuous operation).

3-stage:

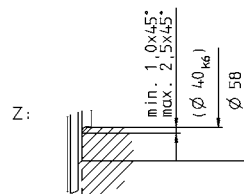
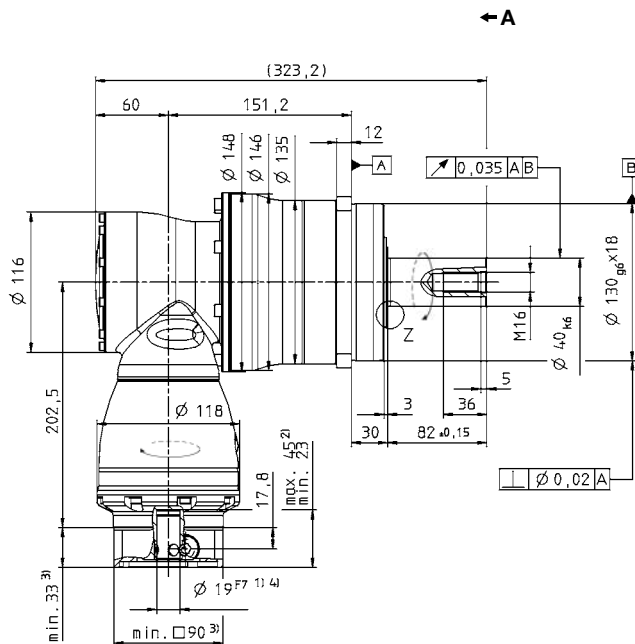
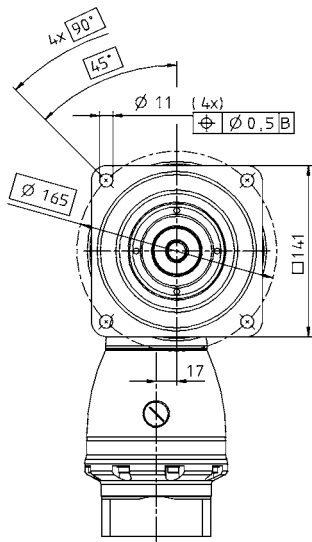

Alternatives: Output shaft variants

Keywayed output shaft in mm
E = key as per DIN 6885, sheet 1, form A

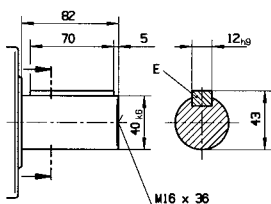

Involute gearing DIN 5480 in mm
X = W 40 x 2 x 30 x 18 x 6m, DIN 5480

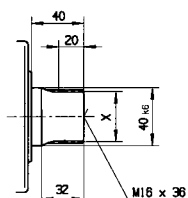

See technical data sheet for available clamping hub diameters (mass moment of inertia). Dimensions available on request.

Non-tolerated dimensions ±1 mm

- 1) Check motor shaft fit.
- 2) Min./Max. permissible motor shaft length. Longer motor shafts are adaptable, please contact us.
- 3) The dimensions depend on the motor.
- 4) Smaller motor shaft diameter is compensated by a bushing with a minimum thickness of 1 mm.

⚠ Motor mounting according to operating manual



SPK+ 180 MF 2-stage

		2-stage												
Ratio ^{a)}	<i>i</i>		12	16	20	25	28	35	40	50	70	100		
Max. acceleration torque (max. 1000 cycles per hour)	T_{2B}	Nm	1100	1100	1100	1100	1100	1100	840	1050	1100	880		
		in.lb	9735	9735	9735	9735	9735	9735	7434	9293	9735	7788		
Nominal output torque (with n_{1N})	T_{2N}	Nm	750	750	750	750	750	750	640	750	750	750		
		in.lb	6638	6638	6638	6638	6638	6638	5664	6638	6638	6638		
Emergency stop torque (permitted 1000 times during the service life of the gearhead)	T_{2Not}	Nm	1600	1600	2000	2000	2750	2000	1600	2000	2750	2200		
		in.lb	14160	14160	17700	17700	24338	17700	14160	17700	24338	19470		
Nominal input speed (with T_{2N} and 20°C ambient temperature) ^{b), c)}	n_{1N}	rpm	1600	1900	1900	2100	1900	2100	2100	2100	2100	2100		
Max. continuous speed (with 20% T_{2N} and 20°C ambient temperature)	n_{1Nocym}	rpm	2300	2600	2600	2800	2600	3000	3000	3000	3000	3000		
Max. input speed	n_{1Max}	rpm	4500	4500	4500	4500	4500	4500	4500	4500	4500	4500		
Mean no load running torque (with $n_1=3000$ rpm and 20°C gearhead temperature) ^{d)}	T_{012}	Nm	9.0	6.5	6.5	5.5	6.0	8.0	6.0	6.0	6.0	6.0		
		in.lb	79.7	57.5	57.5	48.7	53.1	70.8	53.1	53.1	53.1	53.1		
Max. torsional backlash	j_t	arcmin	Standard ≤ 4 / Reduced ≤ 2											
Torsional rigidity	C_{t21}	Nm/ arcmin	175											
		in.lb/ arcmin	1549											
Max. axial force ^{e)}	F_{2AMax}	N	14150											
		lb _f	3184											
Max. radial force ^{e)}	F_{2RMax}	N	14700											
		lb _f	3308											
Max. tilting moment	M_{2KMax}	Nm	1600											
		in.lb	14160											
Efficiency at full load	η	%	94											
Service life (For calculation, see the Chapter "Information")	L_h	h	> 20000											
Weight incl. standard adapter plate	<i>m</i>	kg	45											
		lb _m	99											
Operating noise (with $n_1=3000$ rpm no load)	L_{PA}	dB(A)	≤ 70											
Max. permitted housing temperature		°C	+90											
		F	194											
Ambient temperature		°C	0 to +40											
		F	32 to 104											
Lubrication			Lubricated for life											
Paint			Blue RAL 5002											
Direction of rotation			Motor and gearhead opposite directions											
Protection class			IP 65											
Moment of inertia (relates to the drive) Clamping hub diameter [mm]	K	38	J_f	kgcm ²	24.7	19.5	19.0	16.3	18.6	14.0	12.9	12.8	12.7	12.7
				10 ³ in.lb.s ²	21.9	17.2	16.8	14.4	16.5	12.4	11.4	11.3	11.3	11.2

^{a)} Other ratios up to $i=1000$ available on request

^{b)} Higher speeds are possible if the nominal torque is reduced

^{c)} For higher ambient temperatures, please reduce input speed

^{d)} Idling torques decrease during operation

^{e)} Refers to center of the output shaft or flange

All technical data for front output side applies.

Please request information for rear output side versions.

Please contact us for information on the best configuration for S1 conditions of use (continuous operation).

2-stage:

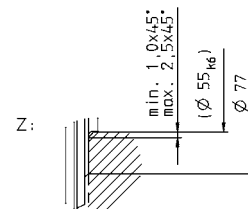
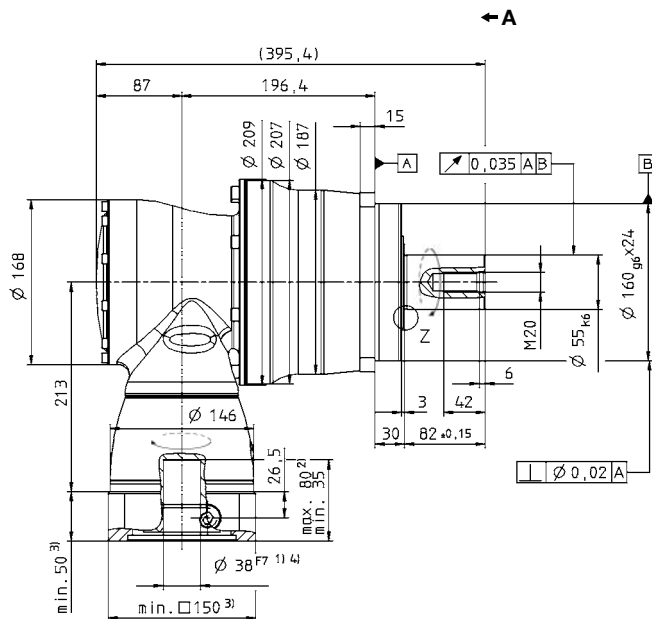
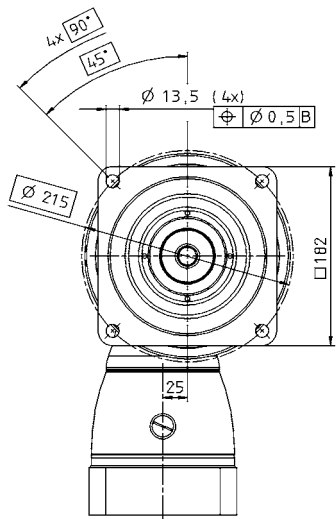

Alternatives: Output shaft variants

Keywayed output shaft in mm
E = key as per DIN 6885, sheet 1, form A

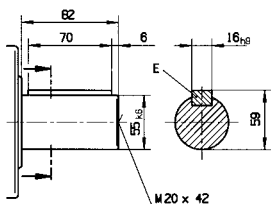

Involute gearing DIN 5480 in mm
X = W 55 x 2 x 30 x 26 x 6m, DIN 5480

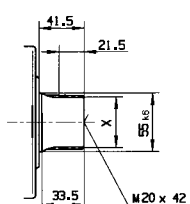

See technical data sheet for available clamping hub diameters (mass moment of inertia). Dimensions available on request.

Non-tolerated dimensions ± 1 mm

- 1) Check motor shaft fit.
- 2) Min./Max. permissible motor shaft length. Longer motor shafts are adaptable, please contact us.
- 3) The dimensions depend on the motor.
- 4) Smaller motor shaft diameter is compensated by a bushing with a minimum thickness of 1 mm.

Motor mounting according to operating manual



SPK+ 180 MF 3-stage

		3-stage																
Ratio ^{a)}	<i>i</i>		64	84	100	125	140	175	200	250	280	350	400	500	700	1000		
Max. acceleration torque (max. 1000 cycles per hour)	T_{2B}	Nm	1100	1100	1100	1100	1100	1100	1100	1100	1100	1100	840	1050	1100	880		
		in.lb	9735	9735	9735	9735	9735	9735	9735	9735	9735	9735	7434	9293	9735	7788		
Nominal output torque (with n_{1N})	T_{2N}	Nm	750	750	750	750	750	750	750	750	750	750	640	750	750	750		
		in.lb	6638	6638	6638	6638	6638	6638	6638	6638	6638	6638	5664	6638	6638	6638		
Emergency stop torque (permitted 1000 times during the service life of the gearhead)	T_{2Not}	Nm	1600	1600	2000	2000	2000	2000	2000	2000	2750	2000	1600	2000	2750	2200		
		in.lb	14160	14160	17700	17700	17700	17700	17700	17700	24338	17700	14160	17700	24338	19470		
Nominal input speed (with T_{2N} and 20°C ambient temperature) ^{b), c)}	n_{1N}	rpm	2900	2900	2900	2900	2900	2900	2900	3200	2900	3200	3900	3900	3900	3900		
Max. continuous speed (with 20% T_{2N} and 20°C ambient temperature)	n_{1Nocym}	rpm	4000	4000	4000	4000	4000	4000	4000	4000	4000	4000	4200	4200	4200	4200		
Max. input speed	n_{1Max}	rpm	4500	4500	4500	4500	4500	4500	4500	4500	4500	4500	4500	4500	4500	4500		
Mean no load running torque (with $n_1=3000$ rpm and 20°C gearhead temperature) ^{d)}	T_{012}	Nm	1	0.5	0.8	0.6	0.6	0.5	0.5	0.4	0.5	0.4	0.4	0.4	0.4	0.4		
		in.lb	8.9	4.4	7.1	5.3	5.3	4.4	4.4	3.5	4.4	3.5	3.5	3.5	3.5	3.5		
Max. torsional backlash	j_t	arcmin	Standard ≤ 4 / Reduced ≤ 2															
Torsional rigidity	C_{t21}	Nm/ arcmin	175															
		in.lb/ arcmin	1549															
Max. axial force ^{e)}	F_{2AMax}	N	14150															
		lb _f	3184															
Max. radial force ^{e)}	F_{2RMax}	N	14700															
		lb _f	3308															
Max. tilting moment	M_{2KMax}	Nm	1600															
		in.lb	14160															
Efficiency at full load	η	%	92															
Service life (For calculation, see the Chapter "Information")	L_h	h	> 20000															
Weight incl. standard adapter plate	<i>m</i>	kg	47.4															
		lb _m	104.8															
Operating noise (with $n_1=3000$ rpm no load)	L_{PA}	dB(A)	< 70															
Max. permitted housing temperature		°C	+90															
		F	194															
Ambient temperature		°C	0 to +40															
		F	32 to 104															
Lubrication			Lubricated for life															
Paint			Blue RAL 5002															
Direction of rotation			Motor and gearhead opposite directions															
Protection class			IP 65															
Moment of inertia (relates to the drive) Clamping hub diameter [mm]	G	24	J_1	kgcm ²	3.97	2.82	3.36	3.22	2.82	2.75	2.50	2.47	2.50	2.44	2.42	2.42	2.42	
				10 ⁻³ in.lb.s ²	3.51	2.50	2.97	2.85	2.50	2.43	2.21	2.19	2.21	2.16	2.14	2.14	2.14	2.14
	K	38	J_1	kgcm ²	10.90	9.74	10.30	10.10	9.74	9.66	9.41	9.38	9.41	9.38	9.33	9.33	9.33	9.33
				10 ⁻³ in.lb.s ²	9.65	8.62	9.12	8.94	8.62	8.55	8.33	8.30	8.33	8.30	8.26	8.26	8.26	8.26

- ^{a)} Other ratios up to i=1000 available on request
- ^{b)} Higher speeds are possible if the nominal torque is reduced
- ^{c)} For higher ambient temperatures, please reduce input speed
- ^{d)} Idling torques decrease during operation
- ^{e)} Refers to center of the output shaft or flange

All technical data for front output side applies.
Please request information for rear output side versions.

Please contact us for information on the best configuration for S1 conditions of use (continuous operation).

3-stage:

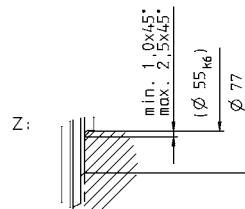
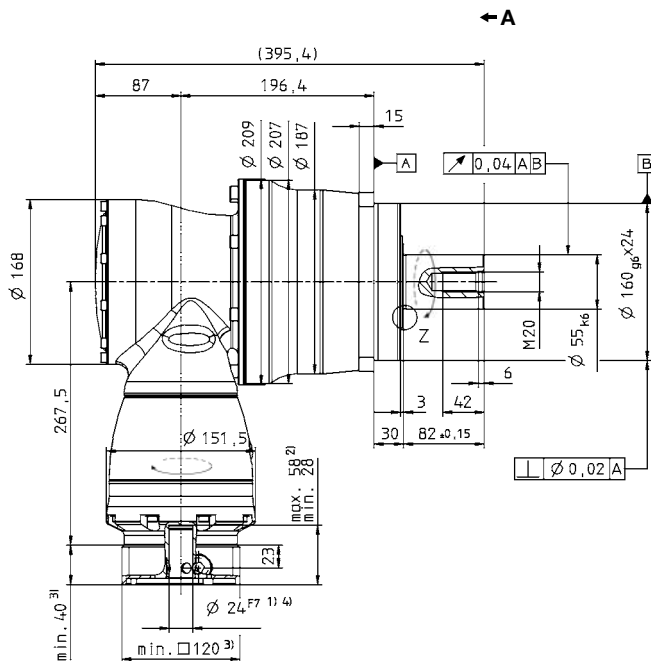
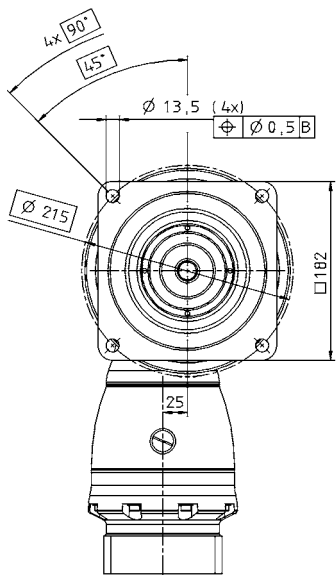

Alternatives: Output shaft variants

Keywayed output shaft in mm
E = key as per DIN 6885, sheet 1, form A

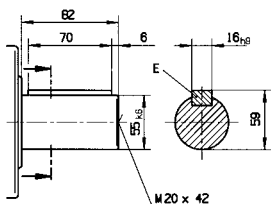

Involute gearing DIN 5480 in mm
X = W 55 x 2 x 30 x 26 x 6m, DIN 5480

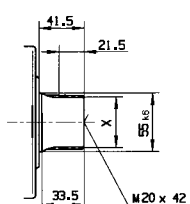

See technical data sheet for available clamping hub diameters (mass moment of inertia). Dimensions available on request.

Non-tolerated dimensions ±1 mm

- 1) Check motor shaft fit.
- 2) Min./Max. permissible motor shaft length. Longer motor shafts are adaptable, please contact us.
- 3) The dimensions depend on the motor.
- 4) Smaller motor shaft diameter is compensated by a bushing with a minimum thickness of 1 mm.

⚠ Motor mounting according to operating manual



SPK+ 210 MF 2-stage

		2-stage												
Ratio ^{a)}	<i>i</i>		12	16	20	25	28	35	40	50	70	100		
Max. acceleration torque (max. 1000 cycles per hour)	T_{2B}	Nm	2500	2500	2500	2500	2400	2400	1850	2300	2400	1900		
		in.lb	22125	22125	22125	22125	21240	21240	16373	20355	21240	16815		
Nominal output torque (with n_m)	T_{2N}	Nm	1500	1500	1500	1500	1400	1500	1400	1500	1400	1000		
		in.lb	13.275	13275	13275	13275	12390	13275	12390	13275	12390	8850		
Emergency stop torque (permitted 1000 times during the service life of the gearhead)	T_{2Not}	Nm	3600	4200	5200	5200	5200	5200	3600	4500	5200	5000		
		in.lb	31860	37170	46020	46020	46020	46020	31860	39825	46020	44250		
Nominal input speed (with T_{2N} and 20°C ambient temperature) ^{b), c)}	n_{1N}	rpm	1500	1700	1700	1900	1700	1900	1700	1700	1700	1700		
Max. continuous speed (with 20% T_{2N} and 20°C ambient temperature)	n_{1Ncym}	rpm	1900	2300	2300	2700	2300	2700	2400	2400	2400	2400		
Max. input speed	n_{1Max}	rpm	4000	4000	4000	4000	4000	4000	4000	4000	4000	4000		
Mean no load running torque (with $n_1=3000$ rpm and 20°C gearhead temperature) ^{d)}	T_{012}	Nm	18.5	17.0	15.0	13.0	14.0	12.0	15.0	15.0	14.0	13.0		
		in.lb	163.7	150.5	132.8	115.1	123.9	106.2	132.8	132.8	123.9	115.1		
Max. torsional backlash	j_t	arcmin	Standard ≤ 4 / Reduced ≤ 2											
Torsional rigidity	C_{t21}	Nm/ arcmin	300	300	300	300	300	300	300	300	300	300		
		in.lb/ arcmin	2.655	2.655	2.655	2.655	2.655	2.655	2.655	2.655	2.655	2.655		
Max. axial force ^{e)}	F_{2AMax}	N	30000											
		lb _f	6750											
Max. radial force ^{e)}	F_{2RMax}	N	21000											
		lb _f	4725											
Max. tilting moment	M_{2KMax}	Nm	3100											
		in.lb	27435											
Efficiency at full load	η	%	94											
Service life (For calculation, see the Chapter "Information")	L_h	h	> 20000											
Weight incl. standard adapter plate	<i>m</i>	kg	82											
		lb _m	181											
Operating noise (with $n_1=3000$ rpm no load)	L_{PA}	dB(A)	≤ 71											
Max. permitted housing temperature	°C		+90											
	F		194											
Ambient temperature	°C		0 to +40											
	F		32 to 104											
Lubrication	Lubricated for life													
Paint	Blue RAL 5002													
Direction of rotation	Motor and gearhead opposite directions													
Protection class	IP 65													
Moment of inertia (relates to the drive) Clamping hub diameter [mm]	M	48	J_1	kgcm ²	78.80	54.60	53.00	43.40	51.50	42.20	30.20	30.00	29.80	29.80
				10 ⁻³ in.lb.s ²	69.74	48.32	46.91	38.41	45.58	37.35	26.73	26.55	26.37	26.37

^{a)} Other ratios available on request

^{b)} Higher speeds are possible if the nominal torque is reduced

^{c)} For higher ambient temperatures, please reduce input speed

^{d)} Idling torques decrease during operation

^{e)} Refers to center of the output shaft or flange

All technical data for front output side applies.

Please request information for rear output side versions.

Please contact us for information on the best configuration for S1 conditions of use (continuous operation).

2-stage:

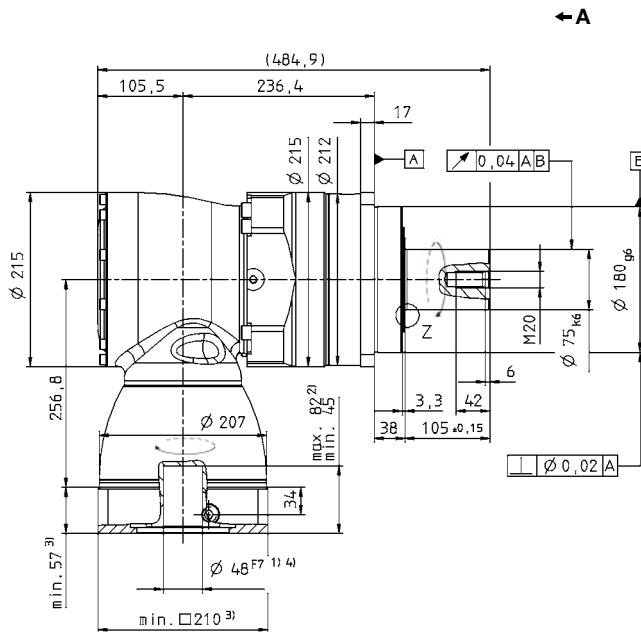
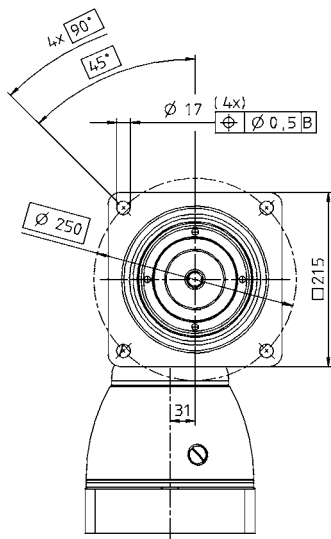

Alternatives: Output shaft variants

Keywayed output shaft in mm
E = key as per DIN 6885, sheet 1, form A

Involute gearing DIN 5480 in mm
X = W 70 x 2 x 30 x 34 x 6m, DIN 5480

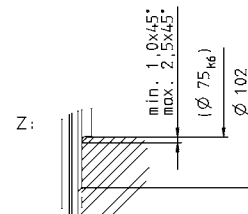
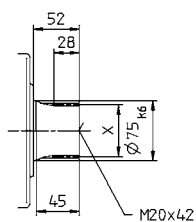
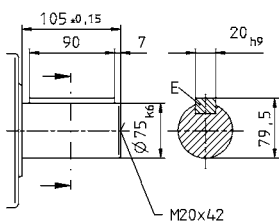

See technical data sheet for available clamping hub diameters (mass moment of inertia). Dimensions available on request.

Non-tolerated dimensions ± 1 mm

- 1) Check motor shaft fit.
- 2) Min./Max. permissible motor shaft length. Longer motor shafts are adaptable, please contact us.
- 3) The dimensions depend on the motor.
- 4) Smaller motor shaft diameter is compensated by a bushing with a minimum thickness of 1 mm.

Motor mounting according to operating manual



SPK+ 210 MF 3-stage

		3-stage																
Ratio ^{a)}	<i>i</i>		64	84	100	125	140	175	200	250	280	350	400	500	700	1000		
Max. acceleration torque (max. 1000 cycles per hour)	T_{2B}	Nm	2400	2400	2500	2500	2500	2500	2500	2500	2400	2400	1900	2350	2400	1900		
		in.lb	21240	21240	22125	22125	22125	22125	22125	22125	21240	21240	16815	20798	21240	16815		
Nominal output torque (with n_m)	T_{2N}	Nm	1500	1500	1500	1500	1500	1500	1500	1500	1400	1400	1500	1500	1400	1000		
		in.lb	13275	13275	13275	13275	13275	13275	13275	13275	12390	12390	13275	13275	12390	8850		
Emergency stop torque (permitted 1000 times during the service life of the gearhead)	T_{2Not}	Nm	4200	3600	5200	5200	5200	5200	5200	5200	5200	5200	3600	4500	5200	5000		
		in.lb	37170	31860	46020	46020	46020	46020	46020	46020	46020	46020	31860	39825	46020	44250		
Nominal input speed (with T_{2N} and 20°C ambient temperature) ^{b), c)}	n_{1N}	rpm	2700	2700	2700	2700	2700	2700	2700	2900	2700	2900	3400	3400	3400	3400		
Max. continuous speed (with 20% T_{2N} and 20°C ambient temperature)	n_{1Ncym}	rpm	3500	3500	3500	3500	3500	3500	3500	3500	3500	3500	3500	3500	3800	3800		
Max. input speed	n_{1Max}	rpm	4000	4000	4000	4000	4000	4000	4000	4000	4000	4000	4000	4000	4000	4000		
Mean no load running torque (with $n_1=3000$ rpm and 20°C gearhead temperature) ^{d)}	T_{012}	Nm	2.4	1.2	1.9	1.7	1.3	1.3	1.0	1.0	1.0	1.0	1.0	1.0	1.0	1.0		
		in.lb	21.2	10.6	16.8	15.0	11.5	11.5	8.9	8.9	8.9	8.9	8.9	8.9	8.9	8.9		
Max. torsional backlash	j_t	arcmin	Standard ≤ 4 / Reduced ≤ 2															
Torsional rigidity	C_{t21}	Nm/ arcmin	300	300	300	300	300	300	300	300	300	300	300	300	300	300		
		in.lb/ arcmin	2.655	2.655	2.655	2.655	2.655	2.655	2.655	2.655	2.655	2.655	2.655	2.655	2.655	2.655		
Max. axial force ^{e)}	F_{2AMax}	N	30000															
		lb _f	6750															
Max. radial force ^{e)}	F_{2RMax}	N	21000															
		lb _f	4725															
Max. tilting moment	M_{2KMax}	Nm	3100															
		in.lb	27435															
Efficiency at full load	η	%	92															
Service life (For calculation, see the Chapter "Information")	L_h	h	> 20000															
Weight incl. standard adapter plate	<i>m</i>	kg	86															
		lb _m	190															
Operating noise (with $n_1=3000$ rpm no load)	L_{PA}	dB(A)	≤ 71															
Max. permitted housing temperature		°C	+90															
		F	194															
Ambient temperature		°C	0 to +40															
		F	32 to 104															
Lubrication			Lubricated for life															
Paint			Blue RAL 5002															
Direction of rotation			Motor and gearhead opposite directions															
Protection class			IP 65															
Moment of inertia (relates to the drive) Clamping hub diameter [mm]	K	38	J_1	kgcm ²	14.00	10.90	12.30	12.00	10.90	10.70	10.10	10.00	10.10	10.00	9.90	9.90	9.90	9.90
				10 ⁻³ in.lb.in ²	12.39	9.65	10.89	10.62	9.65	9.47	8.94	8.85	8.94	8.85	8.76	8.76	8.76	8.76
	M	48	J_1	kgcm ²	28.70	25.60	27.10	26.70	26.70	25.60	24.80	24.70	24.80	24.70	24.60	24.60	24.60	24.60
				10 ⁻³ in.lb.in ²	25.40	22.66	23.98	23.63	23.63	22.66	21.95	21.86	21.95	21.86	21.77	21.77	21.77	21.77

^{a)} Other ratios available on request

^{b)} Higher speeds are possible if the nominal torque is reduced

^{c)} For higher ambient temperatures, please reduce input speed

^{d)} Idling torques decrease during operation

^{e)} Refers to center of the output shaft or flange

All technical data for front output side applies.

Please request information for rear output side versions.

Please contact us for information on the best configuration for S1 conditions of use (continuous operation).

3-stage:

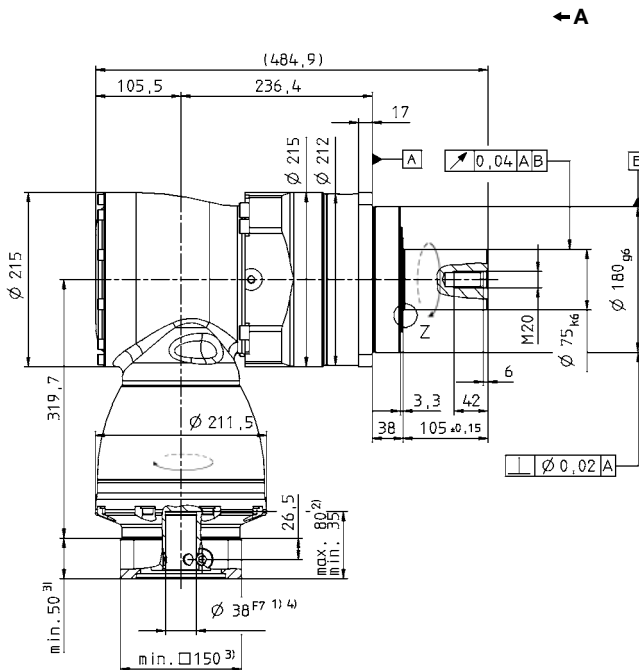
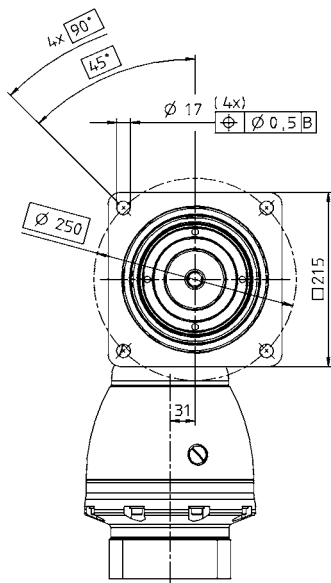

Alternatives: Output shaft variants

Keywayed output shaft in mm
E = key as per DIN 6885, sheet 1, form A

Involute gearing DIN 5480 in mm
X = W 70 x 2 x 30 x 34 x 6m, DIN 5480

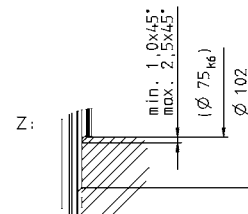
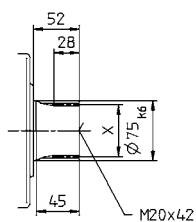
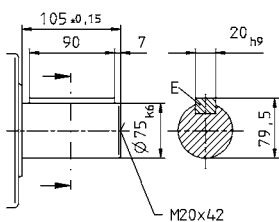

See technical data sheet for available clamping hub diameters (mass moment of inertia). Dimensions available on request.

Non-tolerated dimensions ±1 mm

- 1) Check motor shaft fit.
- 2) Min./Max. permissible motor shaft length. Longer motor shafts are adaptable, please contact us.
- 3) The dimensions depend on the motor.
- 4) Smaller motor shaft diameter is compensated by a bushing with a minimum thickness of 1 mm.

Motor mounting according to operating manual



SPK+ 240 MF 3-stage

		3-stage															
Ratio ^{a)}	<i>i</i>		48	64	100	125	140	175	200	250	280	350	400	500	700	1000	
Max. acceleration torque (max. 1000 cycles per hour)	T_{2B}	Nm	4500	4500	4500	4500	4500	4500	4500	4500	4300	4500	4000	4300	4300	3400	
		in.lb	39825	39825	39825	39825	39825	39825	39825	39825	38055	39825	35400	38055	38055	30090	
Nominal output torque (with n_m)	T_{2N}	Nm	2500	2500	2500	2500	2500	2500	2500	2500	2300	2500	2500	2500	2300	1700	
		in.lb	22125	22125	22125	22125	22125	22125	22125	22125	20355	22125	22125	22125	20355	15045	
Emergency stop torque (permitted 1000 times during the service life of the gearhead)	T_{2Not}	Nm	6400	8000	8500	8500	8500	8500	8500	8500	8500	8500	8500	8500	8500	6800	
		in.lb	56640	70800	75225	75225	75225	75225	75225	75225	75225	75225	75225	75225	75225	60180	
Nominal input speed (with T_{2N} and 20°C ambient temperature) ^{b), c)}	n_{1N}	rpm	1800	1900	1900	2100	1900	2100	2100	2100	2100	2100	2100	2100	2100	2100	
Max. continuous speed (with 20% T_{2N} and 20°C ambient temperature)	n_{1Ncym}	rpm	2000	2200	2600	2600	2300	2300	2300	2300	2300	2300	2300	2300	2300	2300	
Max. input speed	n_{1Max}	rpm	4500	4500	4500	4500	4500	4500	4500	4500	4500	4500	4500	4500	4500	4500	
Mean no load running torque (with $n_1=3000$ rpm and 20°C gearhead temperature) ^{d)}	T_{012}	Nm	11.0	8.0	7.0	7.0	8.0	8.0	7.0	6.0	6.0	6.0	6.0	6.0	6.0	6.0	
		in.lb	94.3	70.8	62.0	62.0	70.8	70.8	62.0	53.1	53.1	53.1	53.1	53.1	53.1	53.1	
Max. torsional backlash	j_t	arcmin	Standard $\leq 5,5$ / Reduced $\leq 3,5$														
Torsional rigidity	C_{t21}	Nm/ arcmin	510	510	510	510	510	510	510	510	510	510	510	510	510	510	
		in.lb/ arcmin	4.514	4.514	4.514	4.514	4.514	4.514	4.514	4.514	4.514	4.514	4.514	4.514	4.514	4.514	
Max. axial force ^{e)}	F_{2AMax}	N	33000														
		lb _f	7425														
Max. radial force ^{e)}	F_{2RMax}	N	30000														
		lb _f	6750														
Max. tilting moment	M_{2KMax}	Nm	5000														
		in.lb	44250														
Efficiency at full load	η	%	92														
Service life (For calculation, see the Chapter "Information")	L_h	h	> 20000														
Weight incl. standard adapter plate	<i>m</i>	kg	93														
		lb _m	206														
Operating noise (with $n_1=3000$ rpm no load)	L_{PA}	dB(A)	≤ 71														
Max. permitted housing temperature		°C	+90														
		F	194														
Ambient temperature		°C	0 to +40														
		F	32 to 104														
Lubrication			Lubricated for life														
Paint			Blue RAL 5002														
Direction of rotation			Motor and gearhead opposite directions														
Protection class			IP 65														
Moment of inertia (relates to the drive) Clamping hub diameter [mm]	K	38	J_1	kgcm ²	26.5	20.00	17.00	17.00	15.00	15.00	13.00	13.00	13.00	13.00	13.00	13.00	13.00
				10 ⁻³ in.lb.s ²	23.40	17.70	15.05	15.05	13.28	13.28	11.51	11.51	11.51	11.51	11.51	11.51	11.51

^{a)} Other ratios available on request

^{b)} Higher speeds are possible if the nominal torque is reduced

^{c)} For higher ambient temperatures, please reduce input speed

^{d)} Idling torques decrease during operation

^{e)} Refers to center of the output shaft or flange

All technical data for front output side applies.

Please request information for rear output side versions.

Please contact us for information on the best configuration for S1 conditions of use (continuous operation).

3-stage:

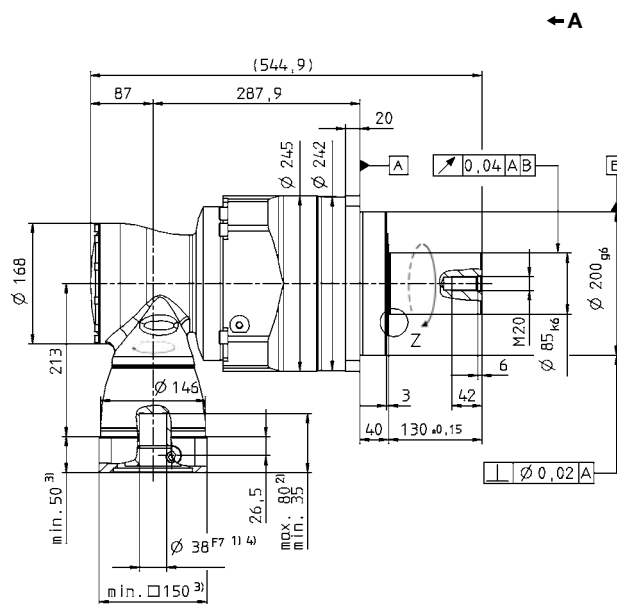
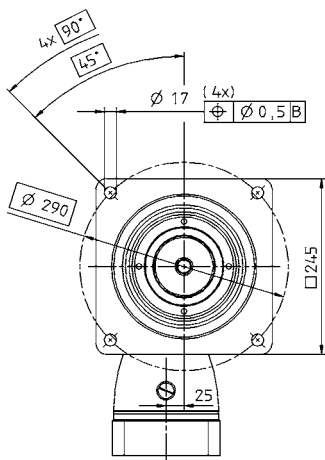

Alternatives: Output shaft variants

Keywayed output shaft in mm
E = key as per DIN 6885, sheet 1, form A

Involute gearing DIN 5480 in mm
X = W 80 x 2 x 30 x 38 x 6m, DIN 5480

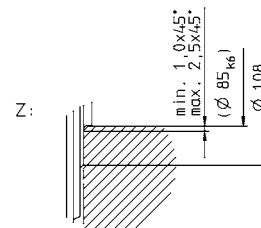
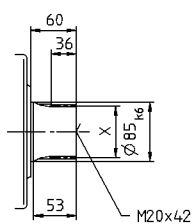
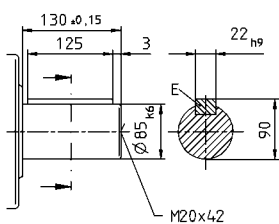

See technical data sheet for available clamping hub diameters (mass moment of inertia). Dimensions available on request.

Non-tolerated dimensions ±1 mm

- 1) Check motor shaft fit.
- 2) Min./Max. permissible motor shaft length. Longer motor shafts are adaptable, please contact us.
- 3) The dimensions depend on the motor.
- 4) Smaller motor shaft diameter is compensated by a bushing with a minimum thickness of 1 mm.

⚠ Motor mounting according to operating manual



SPK+ 240 MF 4-stage i=144-1000

		4-stage															
Ratio ^{a)}	<i>i</i>		144	192	256	300	375	420	500	560	600	700	800	875	1000		
Max. acceleration torque (max. 1000 cycles per hour)	T_{2B}	Nm	4500	4500	4500	4500	4500	4500	4500	4500	4500	4500	4500	4500	4500	4500	
		in.lb	39825	39825	39825	39825	39825	39825	39825	39825	39825	39825	39825	39825	39825	39825	39825
Nominal output torque (with n_m)	T_{2N}	Nm	2500	2500	2500	2500	2500	2500	2500	2500	2500	2500	2500	2500	2500	2500	
		in.lb	22125	22125	22125	22125	22125	22125	22125	22125	22125	22125	22125	22125	22125	22125	22125
Emergency stop torque (permitted 1000 times during the service life of the gearhead)	T_{2Not}	Nm	8000	8000	8000	8500	8500	8500	8500	8500	8500	8500	8500	8500	8500	8500	
		in.lb	70800	70800	70800	75225	75225	75225	75225	75225	75225	75225	75225	75225	75225	75225	75225
Nominal input speed (with T_{2N} and 20°C ambient temperature) ^{b), c)}	n_{1N}	rpm	2700	2900	2900	2900	2900	2900	2900	2900	2900	2900	2900	2900	2900	3200	
Max. continuous speed (with 20% T_{2N} and 20°C ambient temperature)	n_{1Ncym}	rpm	3800	4000	4000	4000	4000	4000	4000	4000	4000	4000	4000	4000	4000	4200	
Max. input speed	n_{1Max}	rpm	4500	4500	4500	4500	4500	4500	4500	4500	4500	4500	4500	4500	4500	4500	
Mean no load running torque (with $n_1=3000$ rpm and 20°C gearhead temperature) ^{d)}	T_{012}	Nm	3.2	2.3	1.6	1.3	0.7	0.9	0.9	0.8	0.7	0.7	0.6	0.6	0.5		
		in.lb	28.3	20.4	14.2	11.5	6.2	8.0	8.0	7.1	6.2	6.2	5.3	5.3	4.4		
Max. torsional backlash	j_t	arcmin	Standard $\leq 5,5$ / Reduced $\leq 3,5$														
Torsional rigidity	C_{t21}	Nm/ arcmin	510	510	510	510	510	510	510	510	510	510	510	510	510	510	
		in.lb/ arcmin	4.514	4.514	4.514	4.514	4.514	4.514	4.514	4.514	4.514	4.514	4.514	4.514	4.514	4.514	
Max. axial force ^{e)}	F_{2AMax}	N	33000														
		lb _f	7425														
Max. radial force ^{e)}	F_{2RMax}	N	30000														
		lb _f	6750														
Max. tilting moment	M_{2KMax}	Nm	5000														
		in.lb	44250														
Efficiency at full load	η	%	90														
Service life (For calculation, see the Chapter "Information")	L_h	h	> 20000														
Weight incl. standard adapter plate	<i>m</i>	kg	96														
		lb _m	212														
Operating noise (with $n_1=3000$ rpm no load)	L_{PA}	dB(A)	≤ 71														
Max. permitted housing temperature		°C	+90														
		F	194														
Ambient temperature		°C	0 to +40														
		F	32 to 104														
Lubrication			Lubricated for life														
Paint			Blue RAL 5002														
Direction of rotation			Motor and gearhead opposite directions														
Protection class			IP 65														
Moment of inertia (relates to the drive) Clamping hub diameter [mm]	G	24	J_t	kgcm ²	5.96	4.30	3.90	3.32	3.31	2.80	3.18	2.80	2.49	2.73	2.49	2.73	2.46
				10 ⁻³ in.lb.s ²	5.28	3.81	3.45	2.94	2.93	2.48	2.82	2.47	2.21	2.42	2.20	2.42	2.18
	K	38	J_t	kgcm ²	12.87	11.19	10.81	10.23	10.22	9.72	10.09	9.71	9.40	9.65	9.40	9.65	9.37
				10 ⁻³ in.lb.s ²	11.39	9.91	9.57	9.05	9.05	8.60	8.93	8.59	8.32	8.54	8.32	8.54	8.29

^{a)} Other ratios available on request

^{b)} Higher speeds are possible if the nominal torque is reduced

^{c)} For higher ambient temperatures, please reduce input speed

^{d)} Idling torques decrease during operation

^{e)} Refers to center of the output shaft or flange

All technical data for front output side applies.

Please request information for rear output side versions.

Please contact us for information on the best configuration for S1 conditions of use (continuous operation).

4-stage:

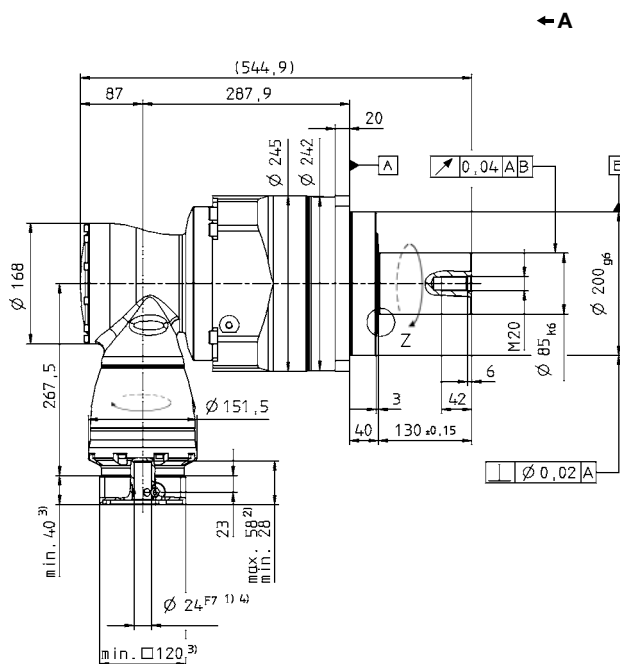
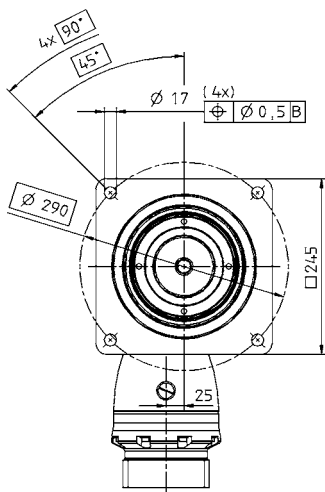

Alternatives: Output shaft variants

Keywayed output shaft in mm
E = key as per DIN 6885, sheet 1, form A

Involute gearing DIN 5480 in mm
X = W 80 x 2 x 30 x 38 x 6m, DIN 5480

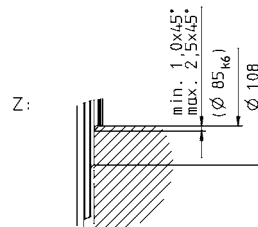
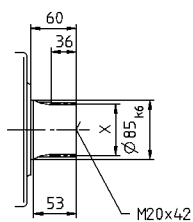
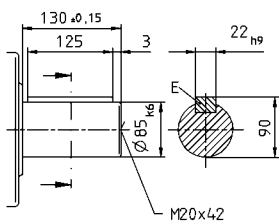

See technical data sheet for available clamping hub diameters (mass moment of inertia). Dimensions available on request.

Non-tolerated dimensions ±1 mm

- 1) Check motor shaft fit.
- 2) Min./Max. permissible motor shaft length. Longer motor shafts are adaptable, please contact us.
- 3) The dimensions depend on the motor.
- 4) Smaller motor shaft diameter is compensated by a bushing with a minimum thickness of 1 mm.

Motor mounting according to operating manual



SPK+ 240 MF 4-stage i=1225-10000

		4-stage										
Ratio ^{a)}	<i>i</i>		1225	1400	1750	2000	2800	3500	5000	7000	10000	
Max. acceleration torque (max. 1000 cycles per hour)	T_{2B}	Nm	4500	4500	4500	4200	4300	4500	4300	4300	3400	
		in.lb	39825	39825	39825	37170	38055	39825	38055	38055	30090	
Nominal output torque (with n_m)	T_{2N}	Nm	2500	2500	2500	2500	2300	2500	2500	2300	1700	
		in.lb	22125	22125	22125	22125	20355	22125	22125	20355	15045	
Emergency stop torque (permitted 1000 times during the service life of the gearhead)	T_{2Not}	Nm	8500	8500	8500	8000	8500	8500	8500	8500	6800	
		in.lb	75225	75225	75225	70800	75225	75225	75225	75225	60180	
Nominal input speed (with T_{2N} and 20°C ambient temperature) ^{b), c)}	n_{1N}	rpm	2900	2900	3200	3900	3900	3900	3900	3900	3900	
Max. continuous speed (with 20% T_{2N} and 20°C ambient temperature)	n_{1Ncym}	rpm	4000	4000	4200	4200	4200	4200	4200	4200	4200	
Max. input speed	n_{1Max}	rpm	4500	4500	4500	4500	4500	4500	4500	4500	4500	
Mean no load running torque (with $n_1=3000$ rpm and 20°C gearhead temperature) ^{d)}	T_{012}	Nm	0.6	0.6	0.4	0.4	0.4	0.4	0.4	0.3	0.3	
		in.lb	5.3	5.3	3.5	3.5	3.5	3.5	3.5	2.7	2.7	
Max. torsional backlash	j_t	arcmin	Standard $\leq 5,5$ / Reduced $\leq 3,5$									
Torsional rigidity	C_{t21}	Nm/ arcmin	510	510	510	510	510	510	510	510	510	
		in.lb/ arcmin	4.514	4.514	4.514	4.514	4.514	4.514	4.514	4.514	4.514	
Max. axial force ^{e)}	F_{2AMax}	N	33000									
		lb _f	7425									
Max. radial force ^{e)}	F_{2RMax}	N	30000									
		lb _f	6750									
Max. tilting moment	M_{2KMax}	Nm	5000									
		in.lb	44250									
Efficiency at full load	η	%	90									
Service life (For calculation, see the Chapter "Information")	L_h	h	> 20000									
Weight incl. standard adapter plate	<i>m</i>	kg	96									
		lb _m	212									
Operating noise (with $n_1=3000$ rpm no load)	L_{PA}	dB(A)	≤ 71									
Max. permitted housing temperature		°C	+90									
		F	194									
Ambient temperature		°C	0 to +40									
		F	32 to 104									
Lubrication			Lubricated for life									
Paint			Blue RAL 5002									
Direction of rotation			Motor and gearhead opposite directions									
Protection class			IP 65									
Moment of inertia (relates to the drive)	G	24	J_1	kgcm ²	2.73	2.49	2.46	2.42	2.42	2.42	2.42	2.42
				10 ⁻³ in.lb.s ²	2.42	2.20	2.17	2.14	2.14	2.14	2.14	2.14
Clamping hub diameter [mm]	K	38	J_1	kgcm ²	9.64	9.40	9.37	9.33	9.33	9.33	9.33	9.33
				10 ⁻³ in.lb.s ²	8.53	8.32	8.29	8.26	8.26	8.26	8.26	8.26

^{a)} Other ratios available on request

^{b)} Higher speeds are possible if the nominal torque is reduced

^{c)} For higher ambient temperatures, please reduce input speed

^{d)} Idling torques decrease during operation

^{e)} Refers to center of the output shaft or flange

All technical data for front output side applies.

Please request information for rear output side versions.

Please contact us for information on the best configuration for S1 conditions of use (continuous operation).

4-stage:

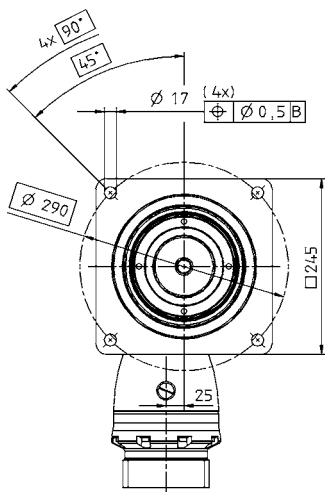

← A

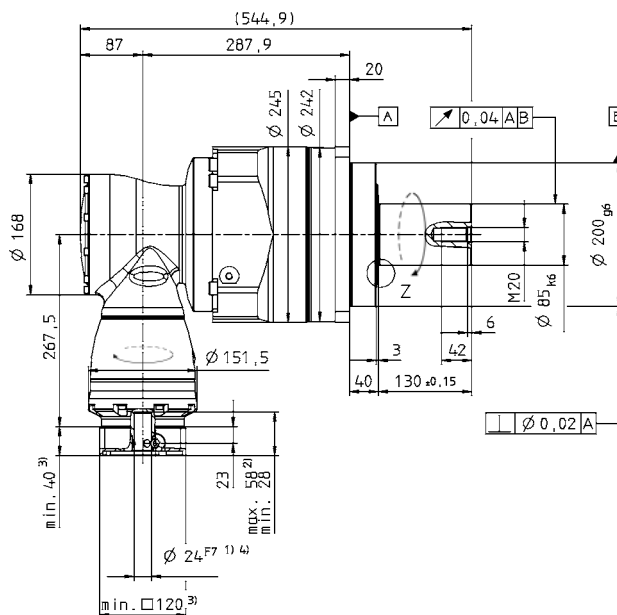

Alternatives: Output shaft variants

Keywayed output shaft in mm
E = key as per DIN 6885, sheet 1, form A

Involute gearing DIN 5480 in mm
X = W 80 x 2 x 30 x 38 x 6m, DIN 5480

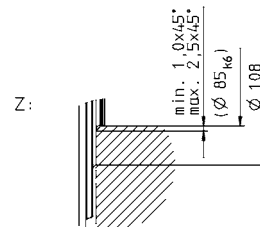
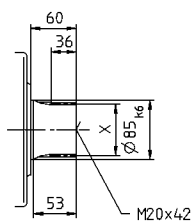
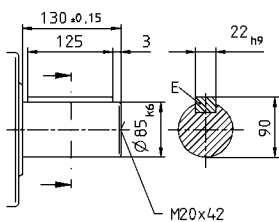

See technical data sheet for available clamping hub diameters (mass moment of inertia). Dimensions available on request.

Non-tolerated dimensions ±1 mm

- 1) Check motor shaft fit.
- 2) Min./Max. permissible motor shaft length. Longer motor shafts are adaptable, please contact us.
- 3) The dimensions depend on the motor.
- 4) Smaller motor shaft diameter is compensated by a bushing with a minimum thickness of 1 mm.

⚠ Motor mounting according to operating manual



HG⁺ – New hollow shaft precision

The successor to our versatile hypoid gearhead with hollow shaft on one/both sides



HG⁺

Specifications \ Version	HG ⁺		
	+	++	+++
Positioning accuracy		▬	
Rigidity	▬		
Smooth-running		▬	
Speed capacity		▬	
Power density	▬		
Max. axial/radial forces		▬	





See our website and our separate flyer for more information about our washdown solutions



Shrink disc

Options

- Plug-in drive coupling
- Washdown version
- ATEX version 
- Food-grade grease 

Accessories

Shrink disc (see page 342)

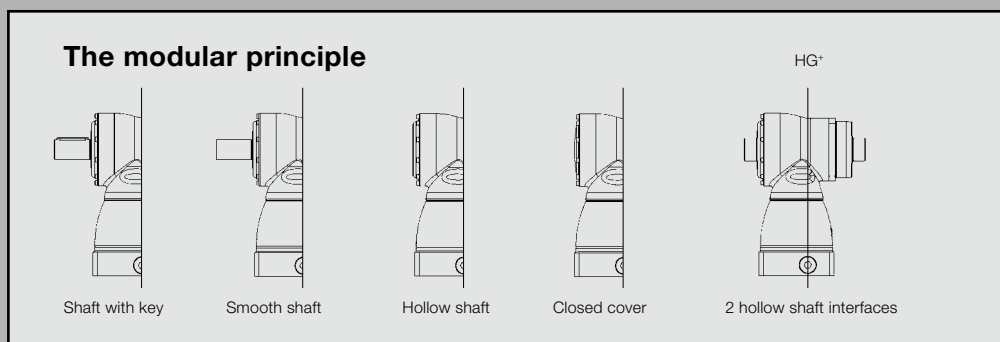

HG+ 060 MF 1/2-stage

		1-stage					2-stage											
Ratio ^{a)}	<i>i</i>	3	4	5	7	10	12	16	20	25	28	35	40	50	70	100		
Max. acceleration torque (max. 1000 cycles per hour)	T_{2B}	Nm	30	30	30	25	20	30	30	30	30	30	30	30	25	20		
		in.lb	266	266	266	221	177	266	266	266	266	266	266	266	266	221	177	
Nominal output torque (with n_{1N})	T_{2N}	Nm	22	22	22	20	15	22	22	22	22	22	22	22	20	15		
		in.lb	195	195	195	177	133	195	195	195	195	195	195	195	195	177	133	
Emergency stop torque (permitted 1000 times during the service life of the gearhead)	T_{2Not}	Nm	40	50	50	45	40	50	50	50	50	50	50	50	45	40		
		in.lb	354	443	443	398	354	443	443	443	443	443	443	443	443	398	354	
Nominal input speed (with T_{2N} and 20°C ambient temperature) ^{b), c)}	n_{1N}	rpm	2500	2700	3000	3000	3000	4400	4400	4400	4400	4400	4400	4800	5500	5500		
Max. continuous speed (with 20% T_{2N} and 20°C ambient temperature)	n_{1Ncym}	rpm	3000	3500	4000	3500	3500	5000	5000	5000	5000	5000	5000	5000	5500	5500		
Max. input speed	n_{1Max}	rpm	6000	6000	6000	6000	6000	6000	6000	6000	6000	6000	6000	6000	6000	6000		
Mean no load running torque (with $n_1=3000$ rpm and 20°C gearhead temperature) ^{d)}	T_{012}	Nm	1.3	1.2	1.1	1.3	1.2	0.2	0.2	0.2	0.2	0.2	0.2	0.1	0.1	0.1		
		in.lb	11.5	10.6	9.7	11.5	10.6	1.8	1.8	1.8	1.8	1.8	1.8	0.9	0.9	0.9		
Max. torsional backlash	j_t	arcmin	≤ 5															
Torsional rigidity	C_{t21}	Nm/ arcmin	2.2	2.3	2.4	2.2	1.9	2.3	2.3	2.3	2.3	2.3	2.3	2.3	2.4	2.2	1.9	
		in.lb/ arcmin	19	20	21	19	17	20	20	20	20	20	20	20	21	19	17	
Max. axial force ^{e)}	F_{2AMax}	N	2400															
		lb _f	540															
Max. radial force ^{e)}	F_{2RMax}	N	2700															
		lb _f	608															
Max. tilting moment	M_{2KMax}	Nm	251															
		in.lb	2220															
Efficiency at full load	η	%	96					94										
Service life (For calculation, see the Chapter "Information")	L_h	h	> 20000															
Weight incl. standard adapter plate	<i>m</i>	kg	2.9					3.2										
		lb _m	6.4					7.1										
Operating noise (with $n_1=3000$ rpm no load)	L_{PA}	dB(A)	≤ 64															
Max. permitted housing temperature		°C	+90															
		F	194															
Ambient temperature		°C	0 to +40															
		F	32 to 104															
Lubrication			Lubricated for life															
Paint			Blue RAL 5002															
Direction of rotation			Motor and gearhead opposite directions															
Protection class			IP 65															
Moment of inertia (relates to the drive) Clamping hub diameter [mm]	B	11	J_t	kgcm ²	-	-	-	-	-	0.09	0.09	0.07	0.07	0.06	0.06	0.06	0.06	
				10 ⁻³ in.lb.in ²	-	-	-	-	-	0.08	0.08	0.07	0.06	0.06	0.06	0.05	0.05	0.05
	C	14	J_t	kgcm ²	0.52	0.44	0.40	0.36	0.34	0.20	0.20	0.19	0.19	0.18	0.18	0.17	0.17	0.17
				10 ⁻³ in.lb.in ²	0.46	0.39	0.35	0.32	0.30	0.18	0.18	0.17	0.16	0.16	0.16	0.15	0.15	0.15
E	19	J_t	kgcm ²	0.87	0.79	0.75	0.71	0.70	-	-	-	-	-	-	-	-		
			10 ⁻³ in.lb.in ²	0.77	0.70	0.66	0.63	0.62	-	-	-	-	-	-	-	-		

Please contact us for information on the best configuration for S1 conditions of use (continuous operation).

- ^{a)} Other ratios available on request
- ^{b)} Higher speeds are possible if the nominal torque is reduced
- ^{c)} For higher ambient temperatures, please reduce input speed
- ^{d)} Idling torques decrease during operation
- ^{e)} Refers to center of the output shaft or flange

All technical data for front output side applies.
Please request information for rear output side versions.

View A

1-stage:

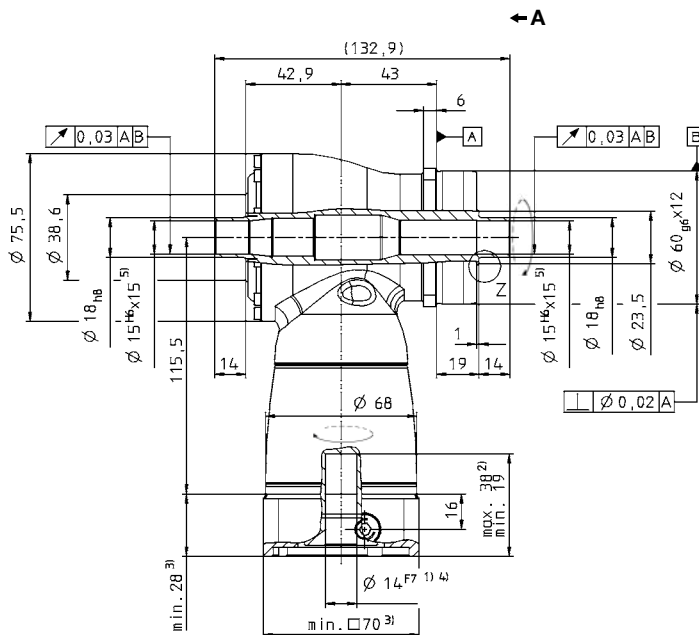
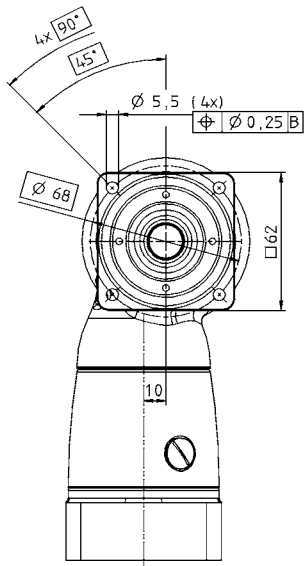

2-stage:

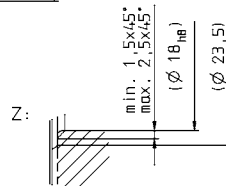
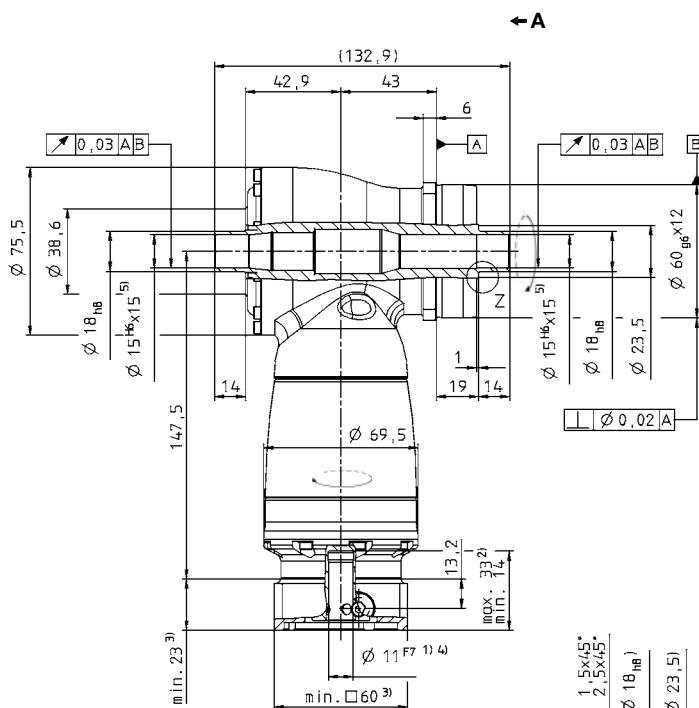
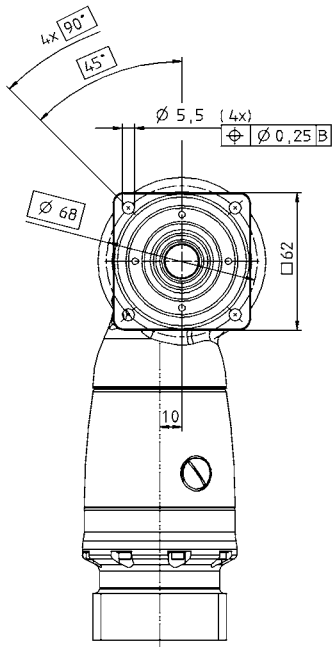

Alternatives: Single output shaft

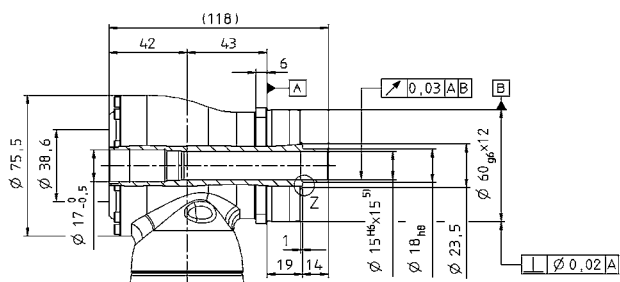

See technical data sheet for available clamping hub diameters (mass moment of inertia). Dimensions available on request.

Non-tolerated dimensions ± 1 mm

- 1) Check motor shaft fit.
- 2) Min./Max. permissible motor shaft length. Longer motor shafts are adaptable, please contact us.
- 3) The dimensions depend on the motor.
- 4) Smaller motor shaft diameter is compensated by a bushing with a minimum thickness of 1 mm.
- 5) Tolerance h6 for mounted shaft.

⚠ Motor mounting according to operating manual



HG+ 075 MF 1/2-stage

		1-stage					2-stage													
Ratio ^{a)}	<i>i</i>	3	4	5	7	10	12	16	20	25	28	35	40	50	70	100				
Max. acceleration torque (max. 1000 cycles per hour)	T_{2B}	Nm	70	70	70	60	50	70	70	70	70	70	70	70	60	50				
		in.lb	620	620	620	531	443	620	620	620	620	620	620	620	620	531	443			
Nominal output torque (with n_{1N})	T_{2N}	Nm	50	50	50	45	40	50	50	50	50	50	50	50	45	40				
		in.lb	443	443	443	398	354	443	443	443	443	443	443	443	443	398	354			
Emergency stop torque (permitted 1000 times during the service life of the gearhead)	T_{2Not}	Nm	95	115	115	110	100	115	115	115	115	115	115	115	110	100				
		in.lb	841	1018	1018	974	885	1018	1018	1018	1018	1018	1018	1018	1018	974	885			
Nominal input speed (with T_{2N} and 20°C ambient temperature) ^{b), c)}	n_{1N}	rpm	2300	2500	2800	2800	2800	3500	3500	3500	3500	3500	3500	3800	4500	4500				
Max. continuous speed (with 207% T_{2N} and 20°C ambient temperature)	n_{1Ncym}	rpm	3000	3500	4000	3500	3500	4500	4500	4500	4500	4500	4500	4500	4500	4500				
Max. input speed	n_{1Max}	rpm	6000	6000	6000	6000	6000	6000	6000	6000	6000	6000	6000	6000	6000	6000				
Mean no load running torque (with $n_1=3000$ rpm and 20°C gearhead temperature) ^{d)}	T_{012}	Nm	2.2	1.9	1.7	2.2	2.0	0.3	0.3	0.2	0.2	0.2	0.2	0.1	0.1	0.1				
		in.lb	19	17	15	19	18	2.7	2.7	1.8	1.8	1.8	1.8	0.9	0.9	0.9				
Max. torsional backlash	j_t	arcmin	≤ 4																	
Torsional rigidity	C_{t21}	Nm/ arcmin	5.3	5.9	6.7	6.6	6.5	5.9	5.9	5.9	5.9	5.9	5.9	5.9	6.7	6.6	6.5			
		in.lb/ arcmin	47	52	60	58	57	52	52	52	52	52	52	52	59	58	58			
Max. axial force ^{e)}	F_{2AMax}	N	3400																	
		lb _f	765																	
Max. radial force ^{e)}	F_{2RMax}	N	4000																	
		lb _f	900																	
Max. tilting moment	M_{2KMax}	Nm	437																	
		in.lb	3867																	
Efficiency at full load	η	%	96					94												
Service life (For calculation, see the Chapter "Information")	L_h	h	> 20000																	
Weight incl. standard adapter plate	<i>m</i>	kg	4.8					5.1												
		lb _m	10.6					11.3												
Operating noise (with $n_1=3000$ rpm no load)	L_{PA}	dB(A)	≤ 66																	
Max. permitted housing temperature		°C	+90																	
		F	194																	
Ambient temperature		°C	0 to +40																	
		F	32 to 104																	
Lubrication			Lubricated for life																	
Paint			Blue RAL 5002																	
Direction of rotation			Motor and gearhead opposite directions																	
Protection class			IP 65																	
Moment of inertia (relates to the drive) Clamping hub diameter [mm]	C	14	J_t	kgcm ²	-	-	-	-	-	0.28	0.27	0.23	0.23	0.20	0.20	0.18	0.18	0.18	0.18	
				10 ⁻³ in.lb.in. ²	-	-	-	-	-	0.25	0.24	0.21	0.20	0.18	0.18	0.16	0.16	0.16	0.16	
	E	19	J_t	kgcm ²	1.46	1.19	1.06	0.95	0.90	0.73	0.71	0.68	0.67	0.63	0.62	0.63	0.63	0.63	0.63	0.63
				10 ⁻³ in.lb.in. ²	1.29	1.05	0.94	0.84	0.79	0.64	0.63	0.60	0.59	0.55	0.55	0.55	0.56	0.55	0.55	0.55
H	28	J_t	kgcm ²	2.86	2.60	2.47	2.36	2.31	-	-	-	-	-	-	-	-	-	-	-	
			10 ⁻³ in.lb.in. ²	2.53	2.30	2.19	2.09	2.04	-	-	-	-	-	-	-	-	-	-	-	

Please contact us for information on the best configuration for S1 conditions of use (continuous operation).

- ^{a)} Other ratios available on request
- ^{b)} Higher speeds are possible if the nominal torque is reduced
- ^{c)} For higher ambient temperatures, please reduce input speed
- ^{d)} Idling torques decrease during operation
- ^{e)} Refers to center of the output shaft or flange

All technical data for front output side applies.
Please request information for rear output side versions.

View A

1-stage:

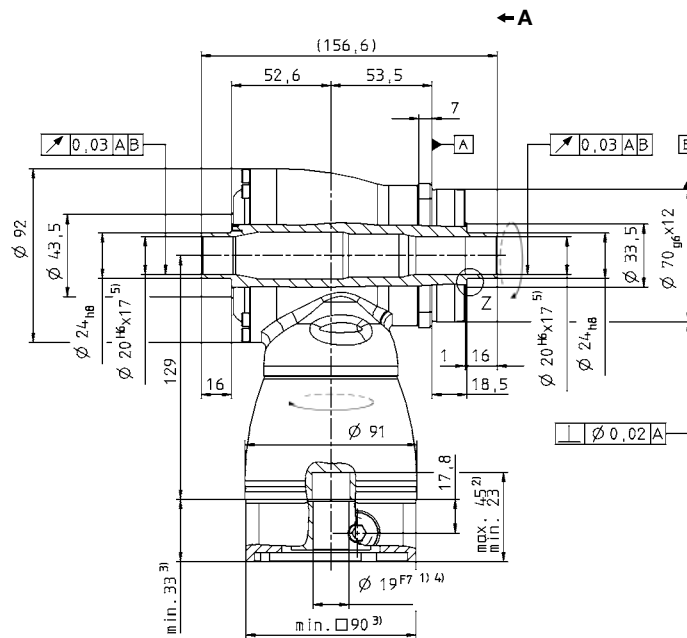
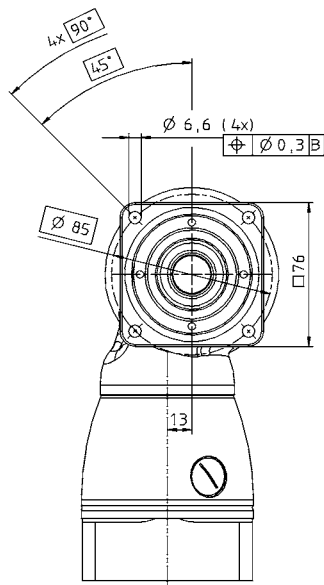

2-stage:

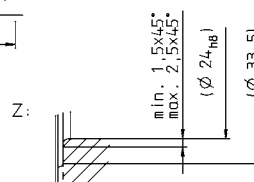
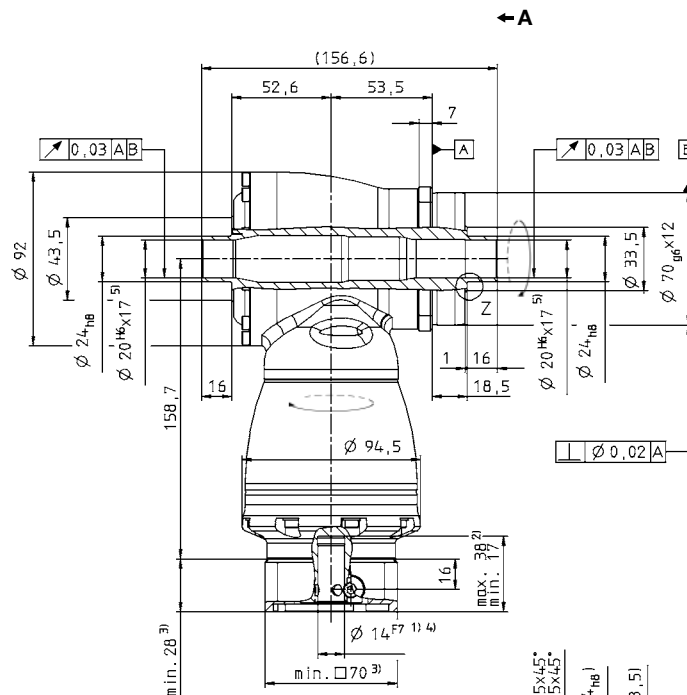
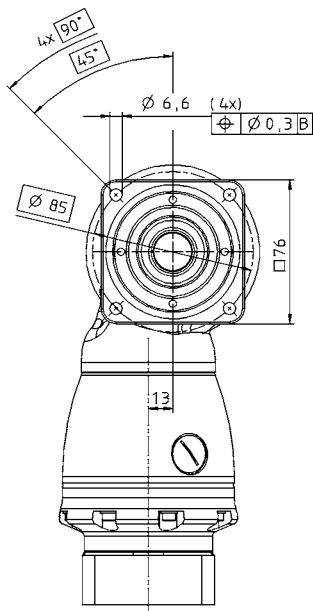

Alternatives: Single output shaft

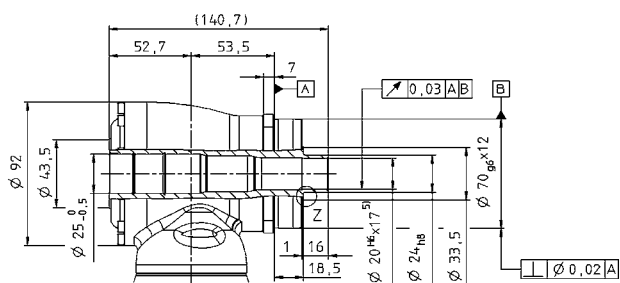

See technical data sheet for available clamping hub diameters (mass moment of inertia). Dimensions available on request.

Non-tolerated dimensions ±1 mm

- 1) Check motor shaft fit.
- 2) Min./Max. permissible motor shaft length. Longer motor shafts are adaptable, please contact us.
- 3) The dimensions depend on the motor.
- 4) Smaller motor shaft diameter is compensated by a bushing with a minimum thickness of 1 mm.
- 5) Tolerance h6 for mounted shaft.

Motor mounting according to operating manual



HG+ 100 MF 1/2-stage

		1-stage					2-stage													
Ratio ^{a)}	<i>i</i>	3	4	5	7	10	12	16	20	25	28	35	40	50	70	100				
Max. acceleration torque (max. 1000 cycles per hour)	T_{2B}	Nm	170	170	170	145	125	170	170	170	170	170	170	170	170	145	125			
		in.lb	1505	1505	1505	1283	1106	1505	1505	1505	1505	1505	1505	1505	1505	1283	1106			
Nominal output torque (with n_{1N})	T_{2N}	Nm	100	100	100	90	80	100	100	100	100	100	100	100	100	90	80			
		in.lb	885	885	885	797	708	885	885	885	885	885	885	885	885	797	708			
Emergency stop torque (permitted 1000 times during the service life of the gearhead)	T_{2Not}	Nm	220	260	260	255	250	260	260	260	260	260	260	260	260	255	250			
		in.lb	1947	2301	2301	2257	2213	2301	2301	2301	2301	2301	2301	2301	2301	2257	2213			
Nominal input speed (with T_{2N} and 20°C ambient temperature) ^{b), c)}	n_{1N}	rpm	2200	2400	2700	2500	2500	3100	3100	3100	3100	3100	3100	3100	3500	4200	4200			
Max. continuous speed (with 20% T_{2N} and 20°C ambient temperature)	n_{1Ncym}	rpm	3000	3400	3800	3400	3400	4000	4000	4000	4000	4000	4000	4000	4000	4200	4200			
Max. input speed	n_{1Max}	rpm	4500	4500	4500	4500	4500	4500	4500	4500	4500	4500	4500	4500	4500	4500	4500			
Mean no load running torque (with $n_1=3000$ rpm and 20°C gearhead temperature) ^{d)}	T_{012}	Nm	4.2	3.3	2.5	3.9	3.1	0.7	0.7	0.6	0.4	0.4	0.3	0.2	0.2	0.2	0.2			
		in.lb	37	29	22	35	27	6.2	6.2	5.3	3.5	3.5	2.7	1.8	1.8	1.8	1.8			
Max. torsional backlash	j_i	arcmin	≤ 4																	
Torsional rigidity	C_{i21}	Nm/ arcmin	10.7	12.1	14.0	14.2	14.4	12.1	12.1	12.1	12.1	12.1	12.1	12.1	14.0	14.2	14.4			
		in.lb/ arcmin	95	107	124	126	127	107	107	107	107	107	107	107	124	126	127			
Max. axial force ^{e)}	F_{2AMax}	N	5700																	
		lb _f	1283																	
Max. radial force ^{e)}	F_{2RMax}	N	6300																	
		lb _f	1418																	
Max. tilting moment	M_{2KMax}	Nm	833																	
		in.lb	7370																	
Efficiency at full load	η	%	96					94												
Service life (For calculation, see the Chapter "Information")	L_h	h	> 20000																	
Weight incl. standard adapter plate	<i>m</i>	kg	9.3					9.5												
		lb _m	21					21												
Operating noise (with $n_1=3000$ rpm no load)	L_{PA}	dB(A)	≤ 66																	
Max. permitted housing temperature		°C	+90																	
		F	194																	
Ambient temperature		°C	0 to +40																	
		F	32 to 104																	
Lubrication			Lubricated for life																	
Paint			Blue RAL 5002																	
Direction of rotation			Motor and gearhead opposite directions																	
Protection class			IP 65																	
Moment of inertia (relates to the drive) Clamping hub diameter [mm]	E	19	J_1	kgcm ²	-	-	-	-	-	1.02	0.97	0.86	0.84	0.75	0.74	0.69	0.69	0.68	0.68	
				10 ⁻³ in.lb.s ²	-	-	-	-	-	0.91	0.86	0.76	0.74	0.66	0.66	0.61	0.61	0.60	0.60	
	G	24	J_1	kgcm ²	-	-	-	-	-	2.59	2.54	2.42	2.40	2.31	2.30	2.26	2.25	2.25	2.25	2.25
				10 ⁻³ in.lb.s ²	-	-	-	-	-	2.29	2.25	2.14	2.13	2.05	2.04	2.00	1.99	1.99	1.99	
	H	28	J_1	kgcm ²	4.64	3.80	3.34	2.98	2.79	-	-	-	-	-	-	-	-	-	-	-
				10 ⁻³ in.lb.s ²	4.10	3.36	2.95	2.64	2.47	-	-	-	-	-	-	-	-	-	-	-
	K	38	J_1	kgcm ²	11.8	11.0	10.6	10.2	10.0	-	-	-	-	-	-	-	-	-	-	-
				10 ⁻³ in.lb.s ²	10.4	9.73	9.34	9.04	8.88	-	-	-	-	-	-	-	-	-	-	-

Please contact us for information on the best configuration for S1 conditions of use (continuous operation).

^{a)} Other ratios available on request

^{b)} Higher speeds are possible if the nominal torque is reduced

^{c)} For higher ambient temperatures, please reduce input speed

^{d)} Idling torques decrease during operation

^{e)} Refers to center of the output shaft or flange

All technical data for front output side applies.

Please request information for rear output side versions.

View A

1-stage:

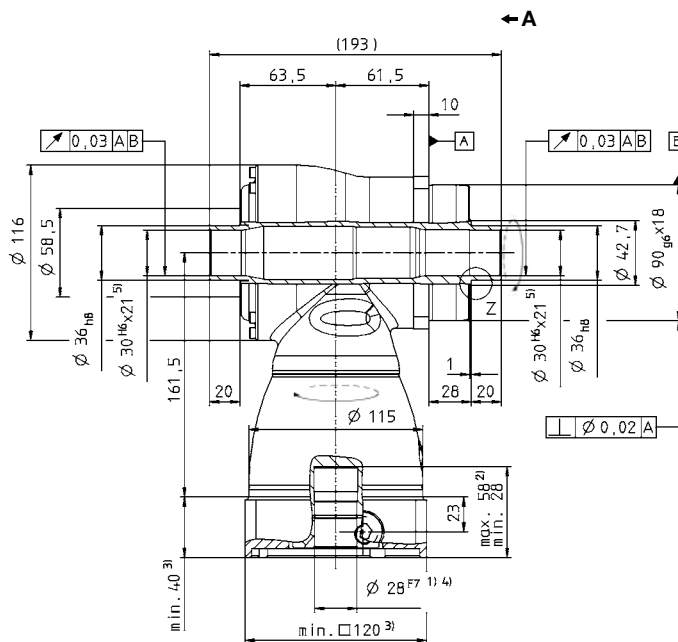
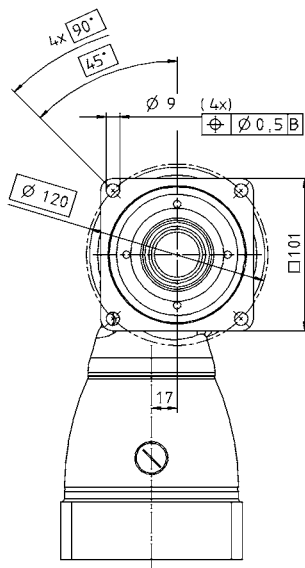

2-stage:

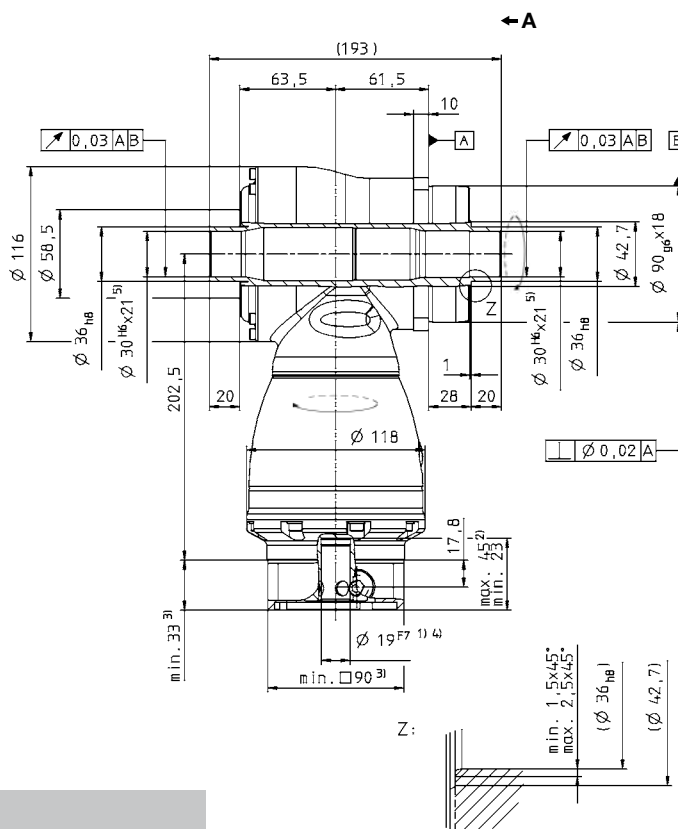
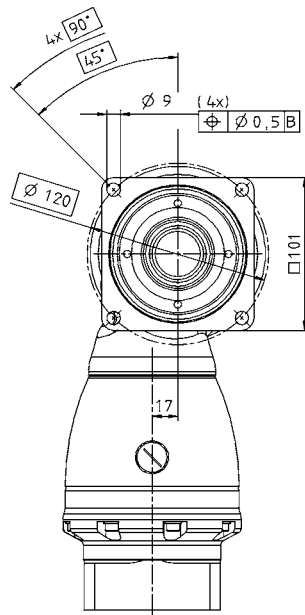

Alternatives: Single output shaft

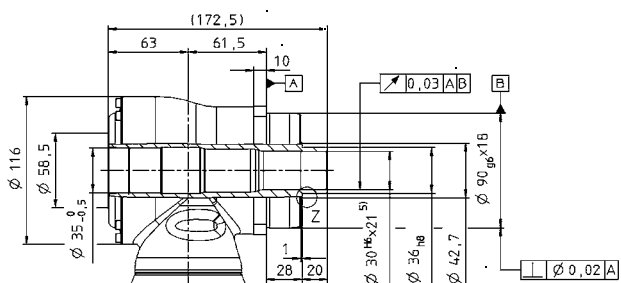

See technical data sheet for available clamping hub diameters (mass moment of inertia). Dimensions available on request.

Non-tolerated dimensions ± 1 mm

- 1) Check motor shaft fit.
- 2) Min./Max. permissible motor shaft length. Longer motor shafts are adaptable, please contact us.
- 3) The dimensions depend on the motor.
- 4) Smaller motor shaft diameter is compensated by a bushing with a minimum thickness of 1 mm.
- 5) Tolerance h6 for mounted shaft.

Motor mounting according to operating manual



HG+ 140 MF 1/2-stage

		1-stage					2-stage												
Ratio ^{a)}	<i>i</i>	3	4	5	7	10	12	16	20	25	28	35	40	50	70	100			
Max. acceleration torque (max. 1000 cycles per hour)	T_{2B}	Nm	300	300	300	250	210	300	300	300	300	300	300	300	250	210			
		in.lb	2655	2655	2655	2213	1859	2655	2655	2655	2655	2655	2655	2655	2213	1859			
Nominal output torque (with n_{1N})	T_{2N}	Nm	190	190	190	175	160	190	190	190	190	190	190	190	175	160			
		in.lb	1682	1682	1682	1549	1416	1682	1682	1682	1682	1682	1682	1682	1549	1416			
Emergency stop torque (permitted 1000 times during the service life of the gearhead)	T_{2Not}	Nm	400	500	500	450	400	500	500	500	500	500	500	500	450	400			
		in.lb	3540	4425	4425	3983	3540	4425	4425	4425	4425	4425	4425	4425	3983	3540			
Nominal input speed (with T_{2N} and 20°C ambient temperature) ^{b), c)}	n_{1N}	rpm	1900	2000	2200	2000	2000	2900	2900	2900	2900	2900	2900	3200	3200	3900			
Max. continuous speed (with 20% T_{2N} and 20°C ambient temperature)	n_{1Nocym}	rpm	2500	2800	3100	2800	2800	4000	4000	4000	4000	4000	4000	4200	4200	4200			
Max. input speed	n_{1Max}	rpm	4500	4500	4500	4500	4500	4500	4500	4500	4500	4500	4500	4500	4500	4500			
Mean no load running torque (with $n_1=3000$ rpm and 20°C gearhead temperature) ^{d)}	T_{012}	Nm	7.7	5.7	5.0	8.3	6.1	1.5	1.0	0.8	0.6	0.6	0.4	0.4	0.3	0.3			
		in.lb	68	50	44	73	54	13.3	8.9	7.1	5.3	5.3	3.5	3.5	2.7	2.7			
Max. torsional backlash	j_i	arcmin	≤ 4																
Torsional rigidity	C_{i21}	Nm/ arcmin	32	36	41	39	38	36	36	36	36	36	36	36	41	39	38		
		in.lb/ arcmin	287	321	360	346	337	319	319	319	319	319	319	319	363	345	336		
Max. axial force ^{e)}	F_{2AMax}	N	9900																
		lb _f	2228																
Max. radial force ^{e)}	F_{2RMax}	N	9500																
		lb _f	2138																
Max. tilting moment	M_{2KMax}	Nm	1692																
		in.lb	14974																
Efficiency at full load	η	%	96					94											
Service life (For calculation, see the Chapter "Information")	L_h	h	> 20000																
Weight incl. standard adapter plate	<i>m</i>	kg	22.6					24											
		lb _m	50					53											
Operating noise (with $n_1=3000$ rpm no load)	L_{PA}	dB(A)	≤ 68																
Max. permitted housing temperature		°C	+90																
		F	194																
Ambient temperature		°C	0 to +40																
		F	32 to 104																
Lubrication			Lubricated for life																
Paint			Blue RAL 5002																
Direction of rotation			Motor and gearhead opposite directions																
Protection class			IP 65																
Moment of inertia (relates to the drive) Clamping hub diameter [mm]	G	24	J_1	kgcm ²	-	-	-	-	-	4.20	3.84	3.27	3.16	2.78	2.73	2.48	2.45	2.43	2.42
				10 ⁻³ in.lb.s ²	-	-	-	-	-	3.71	3.40	2.90	2.80	2.46	2.41	2.20	2.17	2.15	2.14
	K	38	J_1	kgcm ²	25.0	19.1	16.3	14.1	12.8	11.1	10.7	10.2	10.1	9.69	9.64	9.39	9.37	9.34	9.33
				10 ⁻³ in.lb.s ²	22.1	16.9	14.4	12.4	11.3	9.83	9.51	9.01	8.92	8.58	8.53	8.31	8.29	8.27	8.26

Please contact us for information on the best configuration for S1 conditions of use (continuous operation).

- ^{a)} Other ratios available on request
- ^{b)} Higher speeds are possible if the nominal torque is reduced
- ^{c)} For higher ambient temperatures, please reduce input speed
- ^{d)} Idling torques decrease during operation
- ^{e)} Refers to center of the output shaft or flange

All technical data for front output side applies.
Please request information for rear output side versions.

View A

1-stage:

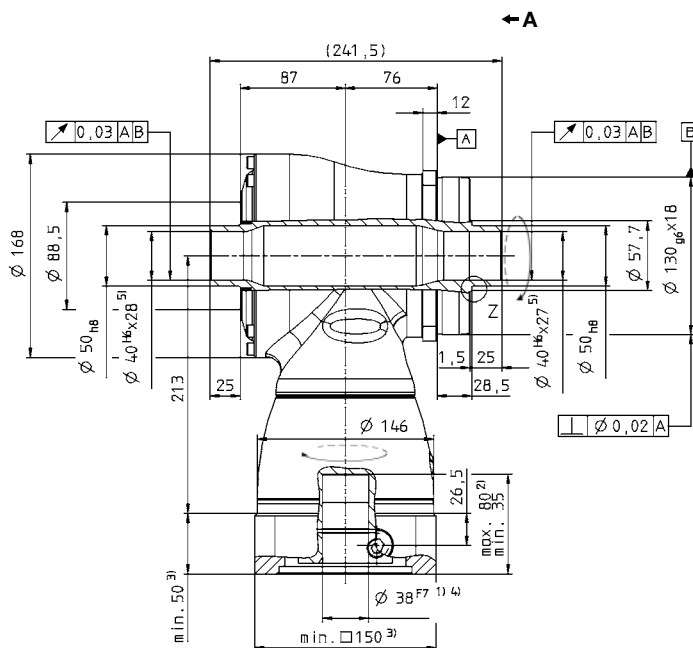
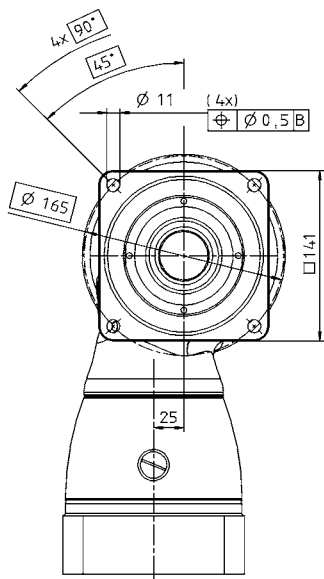

2-stage:

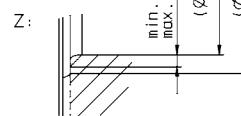
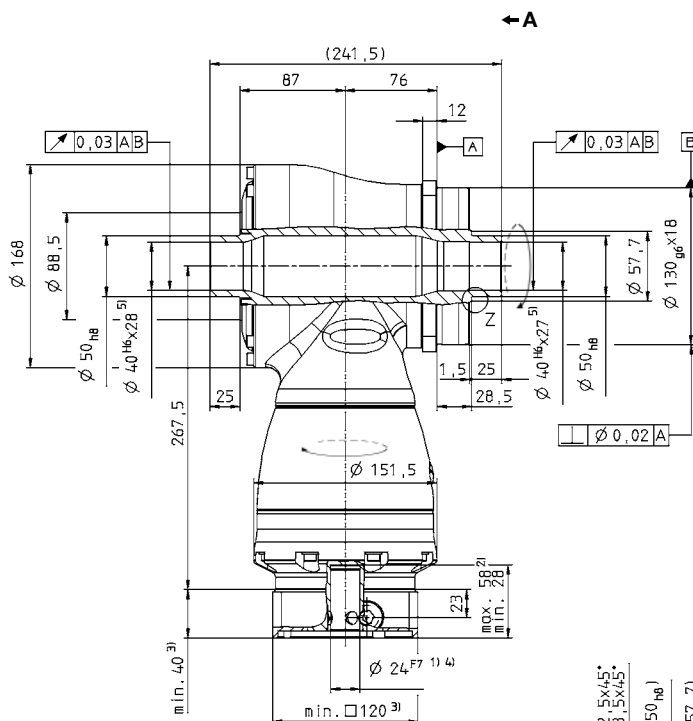
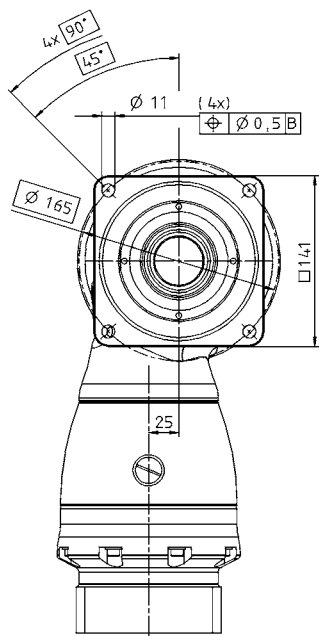

Alternatives: Single output shaft

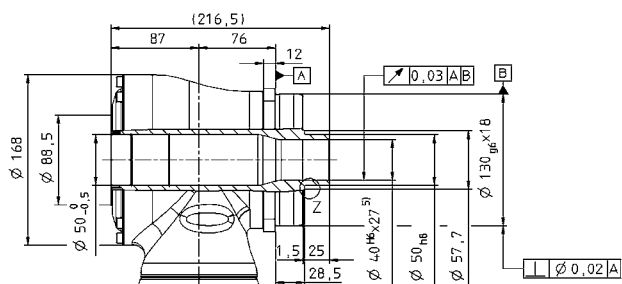

See technical data sheet for available clamping hub diameters (mass moment of inertia). Dimensions available on request.

Non-tolerated dimensions ± 1 mm

- 1) Check motor shaft fit.
- 2) Min./Max. permissible motor shaft length. Longer motor shafts are adaptable, please contact us.
- 3) The dimensions depend on the motor.
- 4) Smaller motor shaft diameter is compensated by a bushing with a minimum thickness of 1 mm.
- 5) Tolerance h6 for mounted shaft.

Motor mounting according to operating manual



HG+ 180 MF 1/2-stage

		1-stage					2-stage												
Ratio ^{a)}	<i>i</i>	3	4	5	7	10	12	16	20	25	28	35	40	50	70	100			
Max. acceleration torque (max. 1000 cycles per hour)	T_{2B}	Nm	640	640	640	550	470	640	640	640	640	640	640	640	640	550	470		
		in.lb	5664	5664	5664	4868	4160	5664	5664	5664	5664	5664	5664	5664	5664	4868	4160		
Nominal output torque (with n_{1N})	T_{2N}	Nm	400	400	400	380	360	400	400	400	400	400	400	400	400	380	360		
		in.lb	3540	3540	3540	3363	3186	3540	3540	3540	3540	3540	3540	3540	3540	3363	3186		
Emergency stop torque (permitted 1000 times during the service life of the gearhead)	T_{2Not}	Nm	900	1050	1050	970	900	1050	1050	1050	1050	1050	1050	1050	1050	970	900		
		in.lb	7965	9293	9293	8585	7965	9293	9293	9293	9293	9293	9293	9293	9293	8585	7965		
Nominal input speed (with T_{2N} and 20°C ambient temperature) ^{b), c)}	n_{1N}	rpm	1600	1800	2000	1800	1800	2700	2700	2700	2700	2700	2700	2700	2900	3200	3400		
Max. continuous speed (with 20% T_{2N} and 20°C ambient temperature)	n_{1Nocym}	rpm	2000	2400	2800	2500	2500	3500	3500	3500	3500	3500	3500	3500	3500	3800	3800		
Max. input speed	n_{1Max}	rpm	4000	4000	4000	4000	4000	4000	4000	4000	4000	4000	4000	4000	4000	4000	4000		
Mean no load running torque (with $n_1=3000$ rpm and 20°C gearhead temperature) ^{d)}	T_{012}	Nm	16.0	13.0	11.0	16.5	14.0	3.3	2.5	2.0	1.8	1.4	1.3	1.0	1.0	1.0	1.0		
		in.lb	142	115	97	146	124	29.2	22.1	17.7	15.9	12.4	11.5	8.9	8.9	8.9	8.9		
Max. torsional backlash	j_i	arcmin	≤ 4																
Torsional rigidity	C_{i21}	Nm/ arcmin	71	80	91	89	88	80	80	80	80	80	80	80	91	89	88		
		in.lb/ arcmin	633	711	803	791	780	708	708	708	708	708	708	708	708	805	788	779	
Max. axial force ^{e)}	F_{2AMax}	N	14200																
		lb _f	3195																
Max. radial force ^{e)}	F_{2RMax}	N	14700																
		lb _f	3308																
Max. tilting moment	M_{2KMax}	Nm	3213																
		in.lb	28435																
Efficiency at full load	η	%	96					94											
Service life (For calculation, see the Chapter "Information")	L_h	h	> 20000																
Weight incl. standard adapter plate	<i>m</i>	kg	45.4					47											
		lb _m	100					104											
Operating noise (with $n_1=3000$ rpm no load)	L_{PA}	dB(A)	≤ 68																
Max. permitted housing temperature			°C																
			F																
Ambient temperature			°C																
			F																
Lubrication			Lubricated for life																
Paint			Blue RAL 5002																
Direction of rotation			Motor and gearhead opposite directions																
Protection class			IP 65																
Moment of inertia (relates to the drive) Clamping hub diameter [mm]	K	38	J_1	kgcm ²	-	-	-	-	-	15.3	13.9	12.3	12.0	10.9	10.7	10.1	10.0	9.95	9.91
				10 ⁻³ in.lb.s ²	-	-	-	-	-	13.5	12.3	10.9	10.6	9.65	9.48	8.96	8.88	8.80	8.77
	M	48	J_1	kgcm ²	73.3	51.6	42.1	34.0	29.7	30.0	28.7	27.0	26.7	25.6	25.4	24.8	24.7	24.7	24.6
				10 ⁻³ in.lb.s ²	64.9	45.6	37.3	30.1	26.3	26.6	25.4	23.9	23.6	22.7	22.5	22.0	21.9	21.8	21.8

Please contact us for information on the best configuration for S1 conditions of use (continuous operation).

- ^{a)} Other ratios available on request
- ^{b)} Higher speeds are possible if the nominal torque is reduced
- ^{c)} For higher ambient temperatures, please reduce input speed
- ^{d)} Idling torques decrease during operation
- ^{e)} Refers to center of the output shaft or flange

All technical data for front output side applies.
Please request information for rear output side versions.

View A

1-stage:

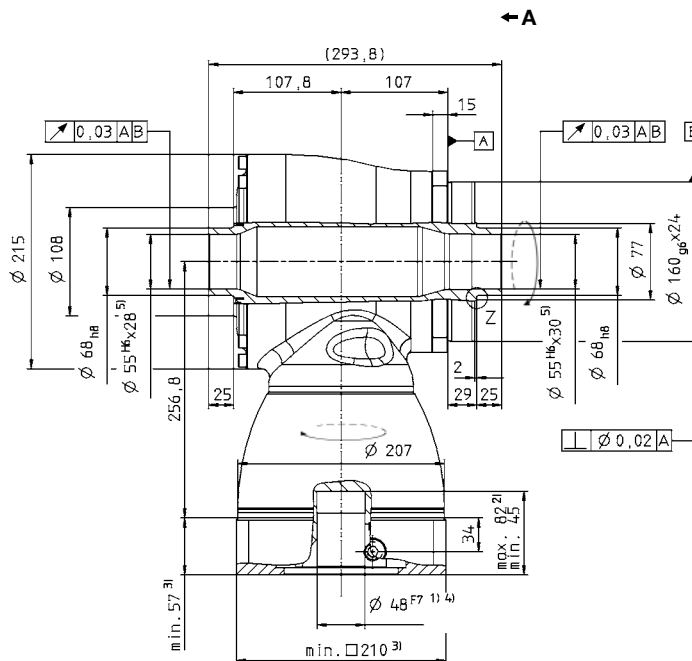
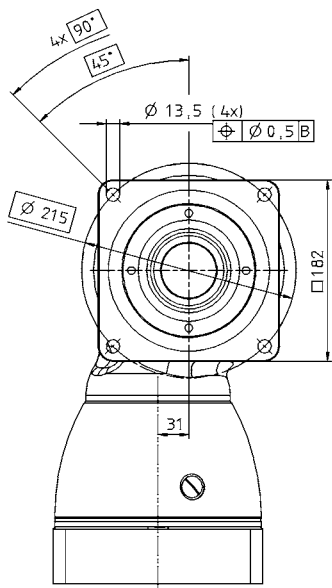

2-stage:

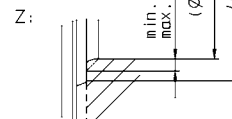
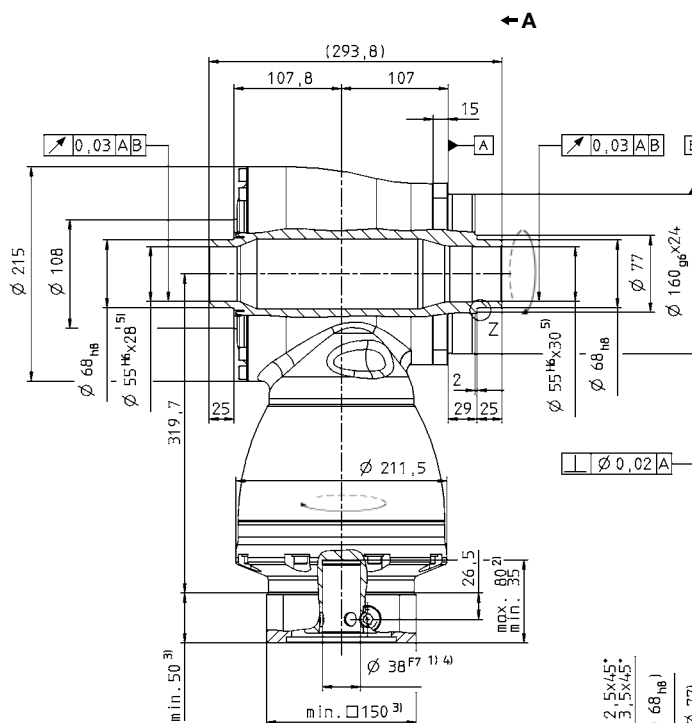
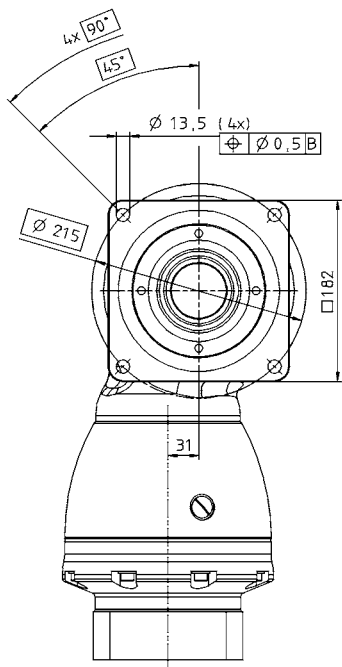

Alternatives: Single output shaft

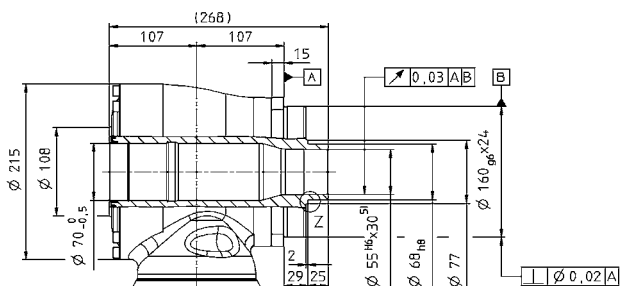

See technical data sheet for available clamping hub diameters (mass moment of inertia). Dimensions available on request.

Non-tolerated dimensions ± 1 mm

- 1) Check motor shaft fit.
- 2) Min./Max. permissible motor shaft length. Longer motor shafts are adaptable, please contact us.
- 3) The dimensions depend on the motor.
- 4) Smaller motor shaft diameter is compensated by a bushing with a minimum thickness of 1 mm.
- 5) Tolerance h6 for mounted shaft.

Motor mounting according to operating manual



HG+

LK⁺/LPK⁺ – Economical right-angle precision

Economical bevel gears with optional planetary stage



LK⁺/LPK⁺

Specifications \ Version	LK ⁺ /LPK ⁺		
	+	++	+++
Positioning accuracy	LK ⁺	LPK ⁺	
Rigidity	LK ⁺	LPK ⁺	
Smooth-running	LK ⁺	LPK ⁺	
Speed capacity		LK ⁺	LPK ⁺
Power density	LK ⁺	LPK ⁺	
Max. axial/radial forces		LK ⁺	LPK ⁺



Belt pulley (PLPB)

Couplings



Shrink disc



LPBK+: Right-angle gearhead with flange for toothed belt pulleys

Rack / Pinion

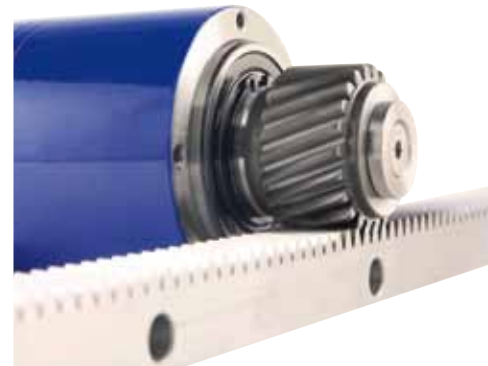

Options

- Smooth output shaft (LPK+)
- Flanged version (LPBK+)
- Food-grade grease 

Accessories

- Rack / Pinion (see page 310)
- Couplings (see page 342)
- Belt pulley (PLPB)
- Shrink disc (see page 342)
- NEMA flange

LK+ 050 1-stage

			1-stage
Ratio	<i>i</i>		1
Max. acceleration torque (max. 1000 cycles per hour)	T_{2B}	Nm	2.5
		in.lb	22
Nominal output torque (with n_{1N})	T_{2N}	Nm	1.2
		in.lb	11
Emergency stop torque (permitted 1000 times during the service life of the gearhead)	T_{2Not}	Nm	5
		in.lb	44
Nominal input speed (with T_{2N} and 20°C ambient temperature) ^{a)}	n_{1N}	rpm	3200
Max. input speed	n_{1Max}	rpm	5000
Mean no load running torque (with $n_1=3000$ rpm and 20°C gearhead temperature)	T_{012}	Nm	0.2
		in.lb	1.8
Max. torsional backlash	j_t	arcmin	≤ 25
Torsional rigidity	C_{t21}	Nm/arcmin	-
		in.lb/arcmin	
Max. axial force ^{b)}	F_{2AMax}	N	100
		lb _f	23
Max. radial force ^{b)}	F_{2RMax}	N	650
		lb _f	146
Efficiency at full load	η	%	95
Service life (For calculation, see the Chapter "Information")	L_n	h	> 20000
Weight incl. standard adapter plate	m	kg	0.7
		lb _m	1.5
Operating noise (with $n_1=3000$ rpm no load)	L_{PA}	dB(A)	≤ 72
Max. permitted housing temperature		°C	+90
		F	194
Ambient temperature		°C	-15 to +40
		F	5 to 104
Lubrication			Lubricated for life
Paint			without
Direction of rotation			Motor and gearhead same direction
Protection class			IP 64
Moment of inertia (relates to the drive)	J_f	kgcm ²	0.14
		10 ⁻² in.lb.s ²	0.12

^{a)} For higher ambient temperatures, please reduce input speed

^{b)} Refers to center of the output shaft, if $n_2 = 1000$ rpm

1-stage:

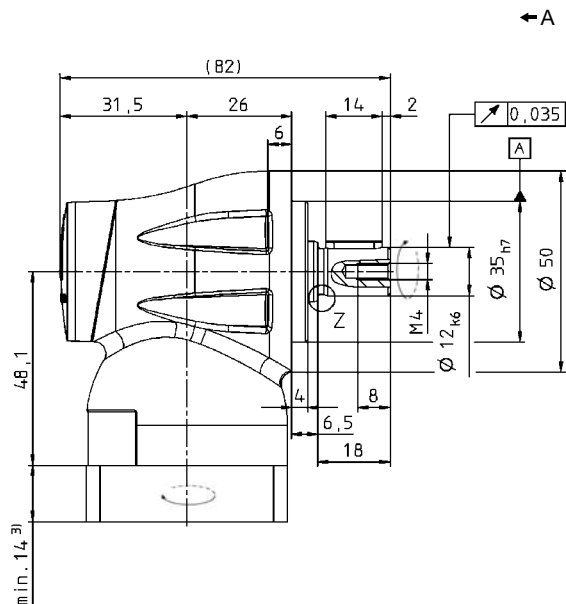
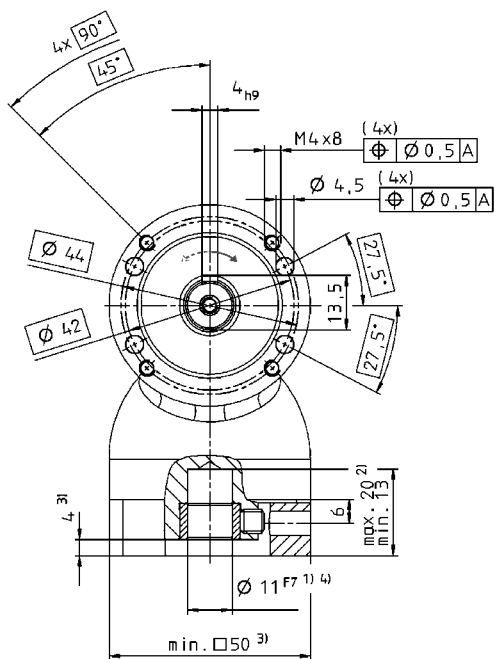
 Non-tolerated dimensions ± 1 mm

- 1) Check motor shaft fit.
- 2) Min./Max. permissible motor shaft length. Longer motor shafts are adaptable, please contact us.
- 3) The dimensions depend on the motor.
- 4) Smaller motor shaft diameter is compensated by a bushing.

Motor mounting according to operating manual



LK+ 070 1-stage

		1-stage	
Ratio	<i>i</i>	1	
Max. acceleration torque (max. 1000 cycles per hour)	T_{2B}	Nm	7
		in.lb	60
Nominal output torque (with n_2)	T_{2N}	Nm	3.7
		in.lb	33
Emergency stop torque (permitted 1000 times during the service life of the gearhead)	T_{2Not}	Nm	15
		in.lb	130
Nominal input speed (with T_{2N} and 20°C ambient temperature) ^{a)}	n_{1N}	rpm	3000
Max. input speed	n_{1Max}	rpm	4500
Mean no load running torque (with $n_1 = 3000$ rpm and 20°C gearhead temperature)	T_{012}	Nm	0.4
		in.lb	3.5
Max. torsional backlash	j_t	arcmin	≤ 20
Torsional rigidity	C_{t21}	Nm/arcmin	-
		in.lb/arcmin	
Max. axial force ^{b)}	F_{2AMax}	N	200
		lb _f	45
Max. radial force ^{b)}	F_{2RMax}	N	1450
		lb _f	330
Efficiency at full load	η	%	95
Service life (For calculation, see the Chapter "Information")	L_n	h	> 20000
Weight incl. standard adapter plate	m	kg	1.9
		lb _m	4.2
Operating noise (with $n_1 = 3000$ rpm no load)	L_{PA}	dB(A)	≤ 73
Max. permitted housing temperature		°C	+90
		F	194
Ambient temperature		°C	-15 to 40
		F	5 to 104
Lubrication			Lubricated for life
Paint			without
Direction of rotation			Motor and gearhead same direction
Protection class			IP 64
Moment of inertia (relates to the drive)	J_i	kgcm ²	0.7
		10 ⁻² in.lb.s ²	0.6

^{a)} For higher ambient temperatures, please reduce input speed

^{b)} Refers to center of the output shaft, if $n_2 = 1000$ rpm

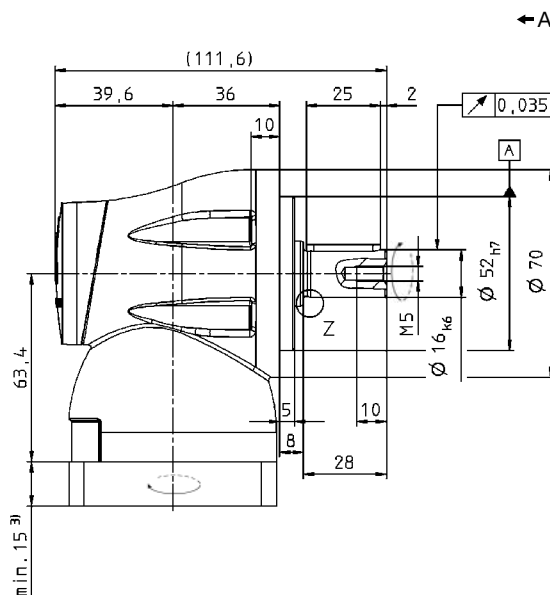
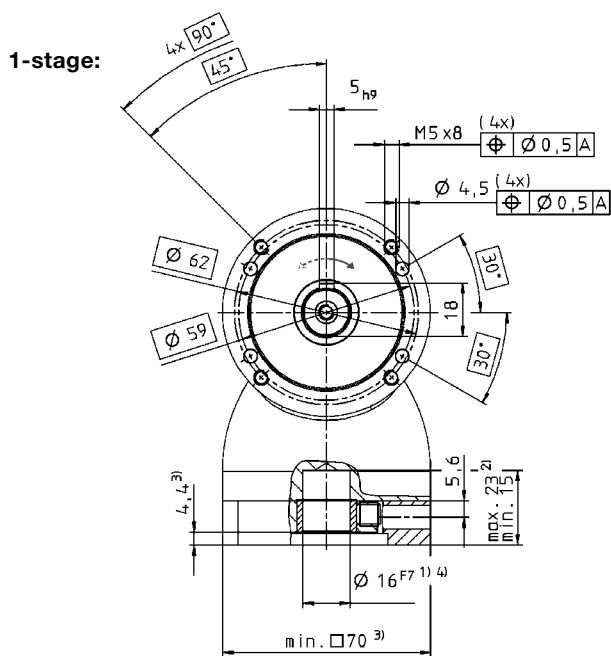

Non-tolerated dimensions ± 1 mm

- 1) Check motor shaft fit.
- 2) Min./Max. permissible motor shaft length. Longer motor shafts are adaptable, please contact us.
- 3) The dimensions depend on the motor.
- 4) Smaller motor shaft diameter is compensated by a bushing.

 Motor mounting according to operating manual



LK+ 090 1-stage

		1-stage	
Ratio	<i>i</i>	1	
Max. acceleration torque (max. 1000 cycles per hour)	T_{2B}	Nm	19
		in.lb	170
Nominal output torque (with n_2)	T_{2N}	Nm	9.3
		in.lb	82
Emergency stop torque (permitted 1000 times during the service life of the gearhead)	T_{2Not}	Nm	37
		in.lb	330
Nominal input speed (with T_{2N} and 20°C ambient temperature) ^{a)}	n_{1N}	rpm	2700
Max. input speed	n_{1Max}	rpm	4000
Mean no load running torque (with $n_1 = 3000$ rpm and 20°C gearhead temperature)	T_{012}	Nm	0.9
		in.lb	8.0
Max. torsional backlash	j_t	arcmin	≤ 15
Torsional rigidity	C_{t21}	Nm/arcmin	1.3
		in.lb/arcmin	11
Max. axial force ^{b)}	F_{2AMax}	N	450
		lb _f	100
Max. radial force ^{b)}	F_{2RMax}	N	2400
		lb _f	540
Efficiency at full load	η	%	95
Service life (For calculation, see the Chapter "Information")	L_n	h	> 20000
Weight incl. standard adapter plate	m	kg	3.2
		lb _m	7.1
Operating noise (with $n_1 = 3000$ rpm no load)	L_{PA}	dB(A)	≤ 76
Max. permitted housing temperature		°C	+90
		F	194
Ambient temperature		°C	-15 to 40
		F	5 to 104
Lubrication			Lubricated for life
Paint			without
Direction of rotation			Motor and gearhead same direction
Protection class			IP 64
Moment of inertia (relates to the drive)	J_i	kgcm ²	3.3
		10 ⁻² in.lb.s ²	2.9

^{a)} For higher ambient temperatures, please reduce input speed

^{b)} Refers to center of the output shaft, if $n_2 = 1000$ rpm

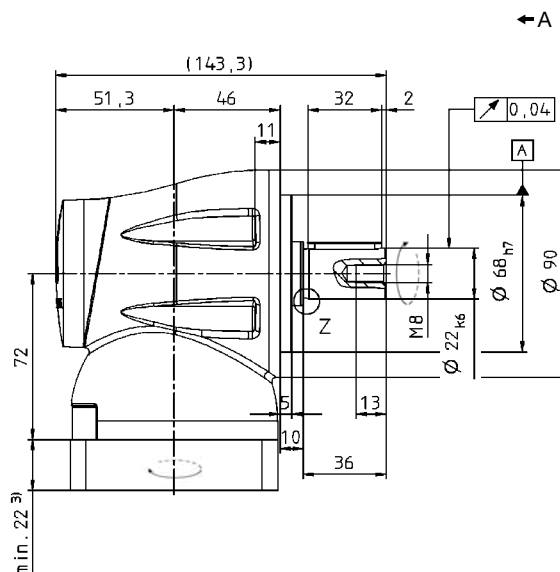
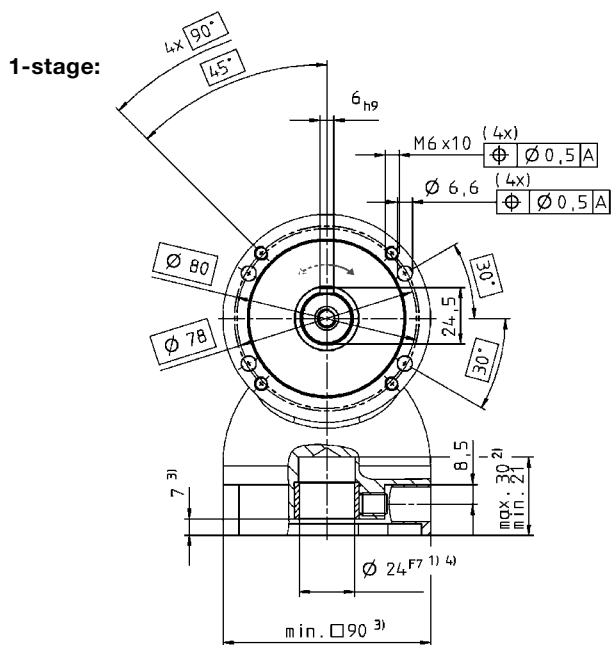

Non-tolerated dimensions ±1 mm

- 1) Check motor shaft fit.
- 2) Min./Max. permissible motor shaft length. Longer motor shafts are adaptable, please contact us.
- 3) The dimensions depend on the motor.
- 4) Smaller motor shaft diameter is compensated by a bushing.

Motor mounting according to operating manual



LK+ 120 1-stage

		1-stage	
Ratio	<i>i</i>	1	
Max. acceleration torque (max. 1000 cycles per hour)	T_{2B}	Nm	45
		in.lb	400
Nominal output torque (with n_2)	T_{2N}	Nm	23
		in.lb	200
Emergency stop torque (permitted 1000 times during the service life of the gearhead)	T_{2Not}	Nm	93
		in.lb	800
Nominal input speed (with T_{2N} and 20°C ambient temperature) ^{a)}	n_{1N}	rpm	2100
Max. input speed	n_{1Max}	rpm	3500
Mean no load running torque (with $n_1 = 3000$ rpm and 20°C gearhead temperature)	T_{012}	Nm	2.5
		in.lb	22
Max. torsional backlash	j_t	arcmin	≤ 10
Torsional rigidity	C_{t21}	Nm/arcmin	-
		in.lb/arcmin	
Max. axial force ^{b)}	F_{2AMax}	N	750
		lb _f	170
Max. radial force ^{b)}	F_{2RMax}	N	4600
		lb _f	1040
Efficiency at full load	η	%	95
Service life (For calculation, see the Chapter "Information")	L_n	h	> 20000
Weight incl. standard adapter plate	m	kg	8.9
		lb _m	20
Operating noise (with $n_1 = 3000$ rpm no load)	L_{PA}	dB(A)	≤ 76
Max. permitted housing temperature		°C	+90
		F	194
Ambient temperature		°C	-15 to 40
		F	5 to 104
Lubrication			Lubricated for life
Paint			without
Direction of rotation			Motor and gearhead same direction
Protection class			IP 64
Moment of inertia (relates to the drive)	J_i	kgcm ²	14
		10 ⁻² in.lb.s ²	12

^{a)} For higher ambient temperatures, please reduce input speed

^{b)} Refers to center of the output shaft, if $n_2 = 1000$ rpm

1-stage:

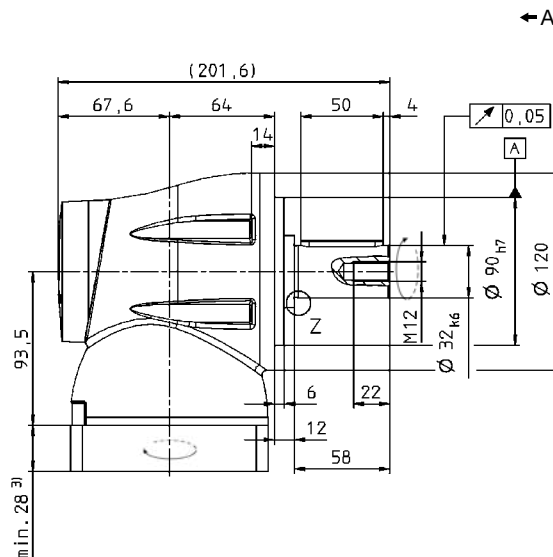
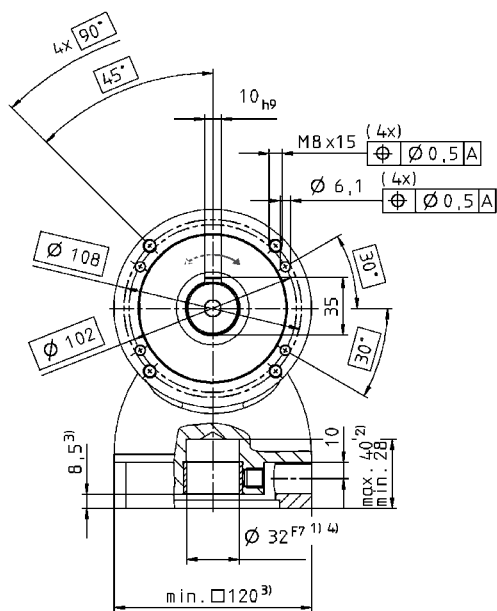
 Non-tolerated dimensions ± 1 mm

- 1) Check motor shaft fit.
- 2) Min./Max. permissible motor shaft length. Longer motor shafts are adaptable, please contact us.
- 3) The dimensions depend on the motor.
- 4) Smaller motor shaft diameter is compensated by a bushing.

 Motor mounting according to operating manual



LK+ 155 1-stage

		1-stage	
Ratio	<i>i</i>		1
Max. acceleration torque (max. 1000 cycles per hour)	T_{2B}	Nm	93
		in.lb	820
Nominal output torque (with n_2)	T_{2N}	Nm	66
		in.lb	580
Emergency stop torque (permitted 1000 times during the service life of the gearhead)	T_{2Not}	Nm	194
		in.lb	1720
Nominal input speed (with T_{2N} and 20°C ambient temperature ^{a)})	n_{1N}	rpm	1600
Max. input speed	n_{1Max}	rpm	3000
Mean no load running torque (with $n_1 = 3000$ rpm and 20°C gearhead temperature)	T_{012}	Nm	4.5
		in.lb	
Max. torsional backlash	j_t	arcmin	≤ 8
			40
Torsional rigidity	C_{t21}	Nm/arcmin	-
		in.lb/arcmin	
Max. axial force ^{b)}	F_{2AMax}	N	1000
		lb _f	225
Max. radial force ^{b)}	F_{2RMax}	N	7500
		lb _f	1690
Efficiency at full load	η	%	95
Service life (For calculation, see the Chapter "Information")	L_n	h	> 20000
Weight incl. standard adapter plate	m	kg	19
		lb _m	42
Operating noise (with $n_1 = 3000$ rpm no load)	L_{PA}	dB(A)	≤ 78
Max. permitted housing temperature		°C	+90
		F	194
Ambient temperature		°C	-15 to 40
		F	5 to 104
Lubrication			Lubricated for life
Paint			without
Direction of rotation			Motor and gearhead same direction
Protection class			IP 64
Moment of inertia (relates to the drive)	J_f	kgcm ²	57
		10 ⁻² in.lb.s ²	51

^{a)} For higher ambient temperatures, please reduce input speed

^{b)} Refers to center of the output shaft, if $n_2 = 1000$ rpm

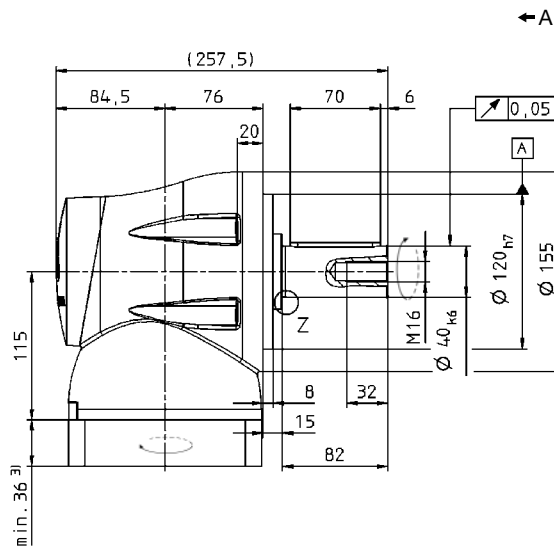
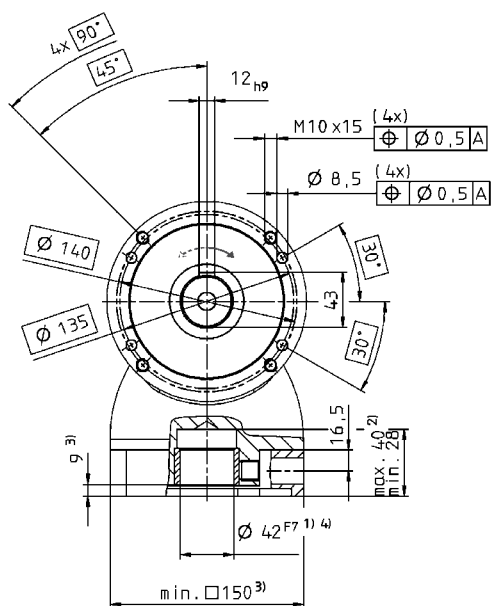
1-stage:

 Non-tolerated dimensions ± 1 mm

- 1) Check motor shaft fit.
- 2) Min./Max. permissible motor shaft length. Longer motor shafts are adaptable, please contact us.
- 3) The dimensions depend on the motor.
- 4) Smaller motor shaft diameter is compensated by a bushing.

 Motor mounting according to operating manual



LPK+ 050 2/3-stage

Ratio	<i>i</i>	2-stage				3-stage							
		4	5	7	10	16	20	25	35	50	70	100	
Max. acceleration torque (max. 1000 cycles per hour)	T_{2B}	Nm	11	12	12	11	11	11	12	12	12	12	11
		in.lb	100	110	110	100	100	100	110	110	110	110	100
Nominal output torque (with n_{1N})	T_{2N}	Nm	5.2	5.7	5.7	5.2	5.2	5.2	5.7	5.7	5.7	5.7	5.2
		in.lb	46	50	50	46	46	46	50	50	50	50	46
Emergency stop torque (permitted 1000 times during the service life of the gearhead)	T_{2Not}	Nm	26	26	26	26	26	26	26	26	26	26	26
		in.lb	230	230	230	230	230	230	230	230	230	230	230
Nominal input speed (with T_{2N} and 20°C ambient temperature ^{a)})	n_{1N}	rpm	3200	3200	3200	3200	3200	3200	3200	3200	3200	3200	
Max. input speed	n_{1Max}	rpm	5000	5000	5000	5000	5000	5000	5000	5000	5000	5000	
Mean no load running torque (with $n_1=3000$ rpm and 20°C gearhead temperature)	T_{012}	Nm	0.2	0.2	0.2	0.2	0.2	0.2	0.2	0.2	0.2	0.2	
		in.lb	1.8	1.8	1.8	1.8	1.8	1.8	1.8	1.8	1.8	1.8	
Max. torsional backlash	j_t	arcmin	≤ 17	≤ 16	≤ 14	≤ 13	≤ 15						
Torsional rigidity	C_{t21}	Nm/arcmin	-				-						
		in.lb/arcmin	-				-						
Max. axial force ^{b)}	F_{2AMax}	N	700				700						
		lb _f	160				160						
Max. radial force ^{b)}	F_{2RMax}	N	650				650						
		lb _f	150				150						
Efficiency at full load	η	%	92				90						
Service life (For calculation, see the Chapter "Information")	L_n	h	> 20000				> 20000						
Weight incl. standard adapter plate	m	kg	1.4				1.6						
		lb _m	3.1				3.5						
Operating noise (with $n_1=3000$ rpm no load)	L_{PA}	dB(A)	≤72										
Max. permitted housing temperature	°C		+90										
	F		194										
Ambient temperature	°C		-15 to 40										
	F		5 to 104										
Lubrication	Lubricated for life												
Paint	Blue RAL 5002												
Direction of rotation	Motor and gearhead same direction												
Protection class	IP 64												
Moment of inertia (relates to the drive)	J_f	kgcm ²	0.16	0.16	0.16	0.16	0.16	0.16	0.16	0.16	0.16	0.16	0.16
		10 ⁻² in.lb.s ²	0.14	0.14	0.14	0.14	0.14	0.14	0.14	0.14	0.14	0.14	0.14

^{a)} For higher ambient temperatures, please reduce input speed

^{b)} Refers to center of the output shaft, if $n_2 = 100$ rpm

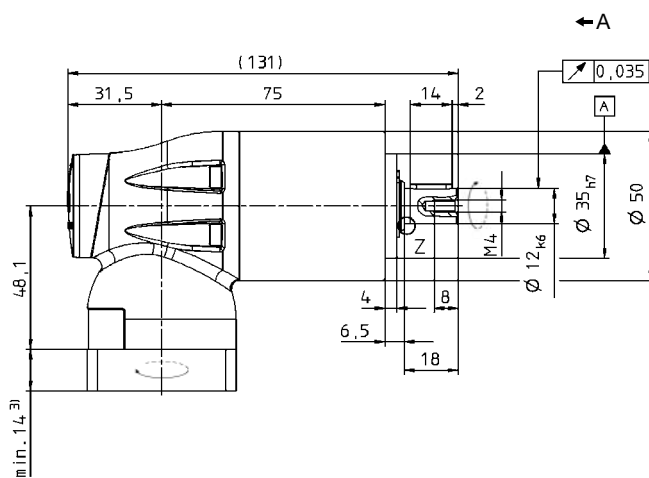
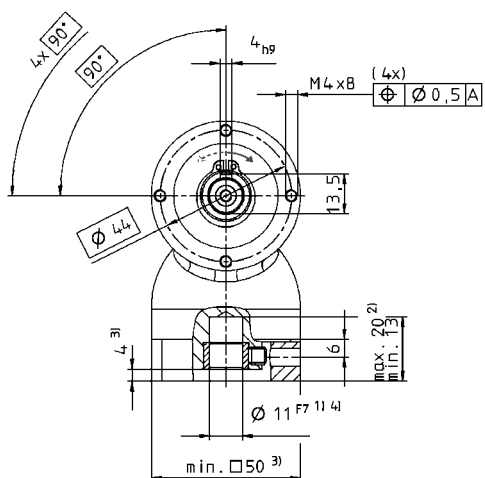
2-stage:



3-stage:

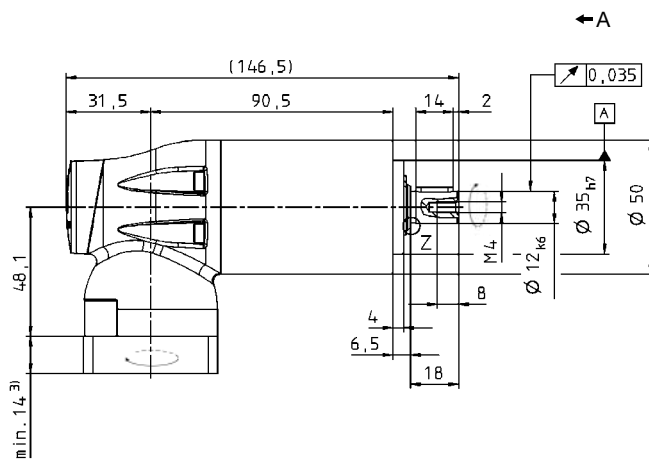
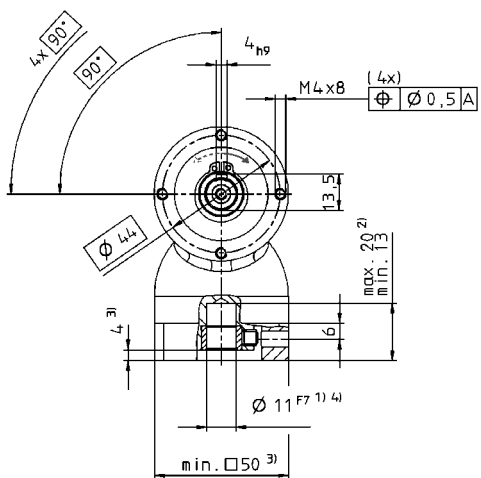

Non-tolerated dimensions ±1 mm

- 1) Check motor shaft fit.
- 2) Min./Max. permissible motor shaft length. Longer motor shafts are adaptable, please contact us.
- 3) The dimensions depend on the motor.
- 4) Smaller motor shaft diameter is compensated by a bushing.

Motor mounting according to operating manual



LK/LPK/LPBK

LPK+ 070 2/3-stage

Ratio	<i>i</i>	2-stage					3-stage										
		3	4	5	7	10	15	16	20	25	30	35	50	70	100		
Max. acceleration torque (max. 1000 cycles per hour)	T_{2B}	Nm	22	29	35	35	32	32	35	35	35	32	35	35	35	32	
		in.lb	190	260	310	310	280	280	310	310	310	280	310	310	310	280	
Nominal output torque (with n_{1N})	T_{2N}	Nm	11	15	18	18	16.5	16.5	18	18	18	16.5	18	18	18	16.5	
		in.lb	100	130	160	160	150	150	160	160	160	160	160	160	160	160	
Emergency stop torque (permitted 1000 times during the service life of the gearhead)	T_{2Not}	Nm	45	60	75	75	75	75	75	75	75	75	75	75	75	75	
		in.lb	400	530	664	660	660	660	660	660	660	660	660	660	660	660	
Nominal input speed (with T_{2N} and 20°C ambient temperature ^{a)})	n_{1N}	rpm	3000	3000	3000	3000	3000	3000	3000	3000	3000	3000	3000	3000	3000		
Max. input speed	n_{1Max}	rpm	4500	4500	4500	4500	4500	4500	4500	4500	4500	4500	4500	4500	4500		
Mean no load running torque (with $n_1=3000$ rpm and 20°C gearhead temperature)	T_{012}	Nm	0.6	0.55	0.5	0.44	0.44	0.44	0.44	0.44	0.44	0.44	0.44	0.44	0.44	0.4	
		in.lb	5.3	4.9	4.4	3.9	3.9	3.9	3.9	3.9	3.9	3.9	3.9	3.9	3.9	3.5	
Max. torsional backlash	j_t	arcmin	≤ 15	≤ 14	≤ 13	≤ 11	≤ 11	≤ 12									
Torsional rigidity	C_{t21}	Nm/arcmin	-	-	2	2	2	3	3	3	3	3	3	3	3	3	
		in.lb/arcmin	-	-	17	21	21	23	27	27	27	27	25	27	28	28	25
Max. axial force ^{b)}	F_{2AMax}	N	1550					1550									
		lb _f	350					350									
Max. radial force ^{b)}	F_{2RMax}	N	1450					1450									
		lb _f	330					330									
Efficiency at full load	η	%	92					90									
Service life (For calculation, see the Chapter "Information")	L_n	h	> 20000					> 20000									
Weight incl. standard adapter plate	m	kg	3.8					4.2									
		lb _m	8.4					9.3									
Operating noise (with $n_1=3000$ rpm no load)	L_{PA}	dB(A)	≤ 73														
Max. permitted housing temperature		°C	+90														
		F	194														
Ambient temperature		°C	-15 to 40														
		F	5 to 104														
Lubrication			Lubricated for life														
Paint			Blue RAL 5002														
Direction of rotation			Motor and gearhead same direction														
Protection class			IP 64														
Moment of inertia (relates to the drive)	J_f	kgcm ²	0.85	0.85	0.85	0.85	0.85	0.85	0.85	0.85	0.85	0.85	0.85	0.85	0.85	0.85	
		10 ⁻² in.lb.s ²	0.75	0.75	0.75	0.75	0.75	0.75	0.75	0.75	0.75	0.75	0.75	0.75	0.75	0.75	

^{a)} For higher ambient temperatures, please reduce input speed

^{b)} Refers to center of the output shaft, if $n_2 = 100$ rpm

2-stage:

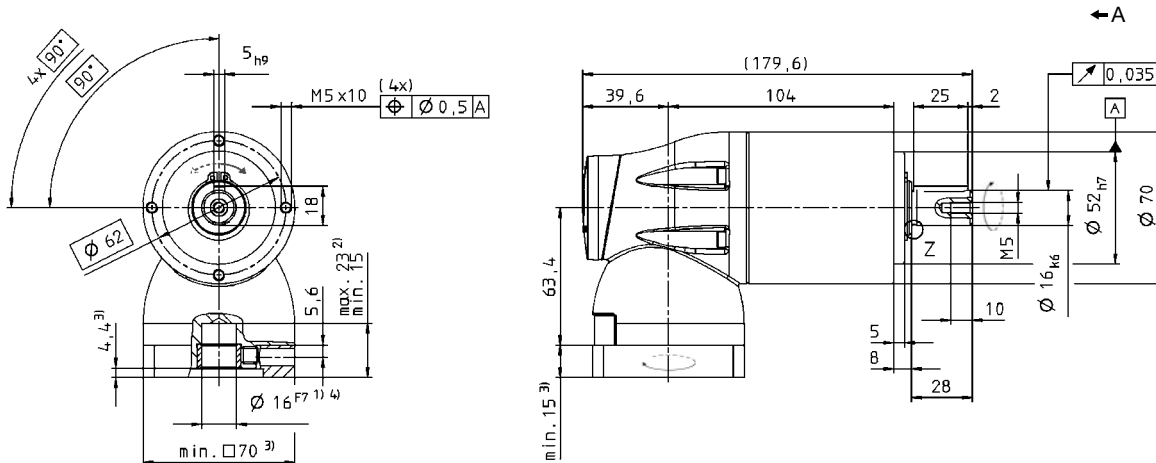

3-stage:

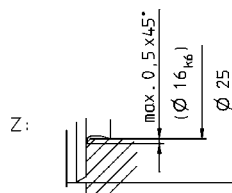
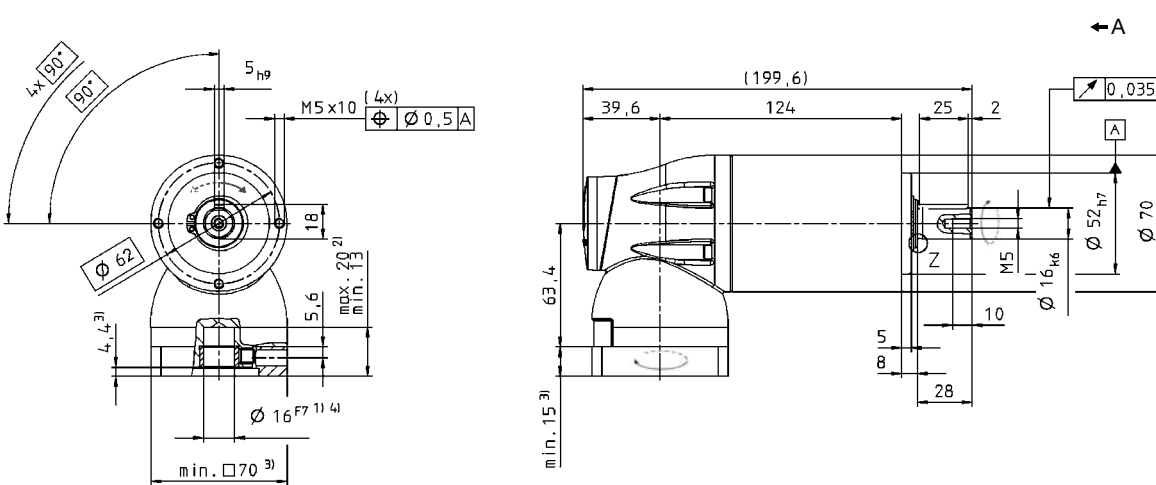

Non-tolerated dimensions ± 1 mm

- 1) Check motor shaft fit.
- 2) Min./Max. permissible motor shaft length. Longer motor shafts are adaptable, please contact us.
- 3) The dimensions depend on the motor.
- 4) Smaller motor shaft diameter is compensated by a bushing.

Motor mounting according to operating manual



LK/LPK/LPBK

LPBK+ 070 2-stage

		2-stage					
Ratio	<i>i</i>	3	4	5	7	10	
Max. acceleration torque (max. 1000 cycles per hour)	T_{2B}	Nm	22	29	35	35	32
		in.lb	190	260	310	310	280
Nominal output torque (with n_{1N})	T_{2N}	Nm	11	15	18	18	16.5
		in.lb	100	130	160	160	150
Emergency stop torque (permitted 1000 times during the service life of the gearhead)	T_{2Not}	Nm	45	60	75	75	75
		in.lb	400	530	660	660	660
Nominal input speed (with T_{2N} and 20°C ambient temperature ^{a)})	n_{1N}	rpm	3000	3000	3000	3000	3000
Max. input speed	n_{1Max}	rpm	4500	4500	4500	4500	4500
Mean no load running torque (with $n_1=3000$ rpm and 20°C gearhead temperature)	T_{012}	Nm	0.6	0.55	0.5	0.45	0.45
		in.lb	5.3	4.9	4.4	4.0	4.0
Max. torsional backlash	j_t	arcmin	≤ 15	≤ 14	≤ 13	≤ 11	≤ 11
Torsional rigidity	C_{t21}	Nm/arcmin	–	–	–	–	–
		in.lb/arcmin	–	–	–	–	–
Max. axial force ^{b)}	F_{2AMax}	N	1550				
		lb _f	350				
Max. radial force ^{c)}	F_{2RMax}	N	3000				
		lb _f	680				
Efficiency at full load	η	%	92				
Service life (For calculation, see the Chapter "Information")	L_n	h	> 20000				
Weight incl. standard adapter plate	m	kg	3.4				
		lb _m	7.5				
Operating noise (with $n_1=3000$ rpm no load)	L_{PA}	dB(A)	≤73				
Max. permitted housing temperature		°C	+90				
		F	194				
Ambient temperature		°C	-15 to 40				
		F	5 to 104				
Lubrication			Lubricated for life				
Paint			Blue RAL 5002				
Direction of rotation			Motor and gearhead same direction				
Protection class			IP 64				
Moment of inertia (relates to the drive)	J_i	kgcm ²	0.85	0.85	0.85	0.85	0.85
		10 ⁻² in.lb.s ²	0.75	0.75	0.75	0.75	0.75

^{a)} For higher ambient temperatures, please reduce input speed

^{b)} Refers to center of the output shaft, if $n_2 = 100$ rpm

^{c)} With mounted PLPB+ belt pulley and 100 rpm

2-stage:

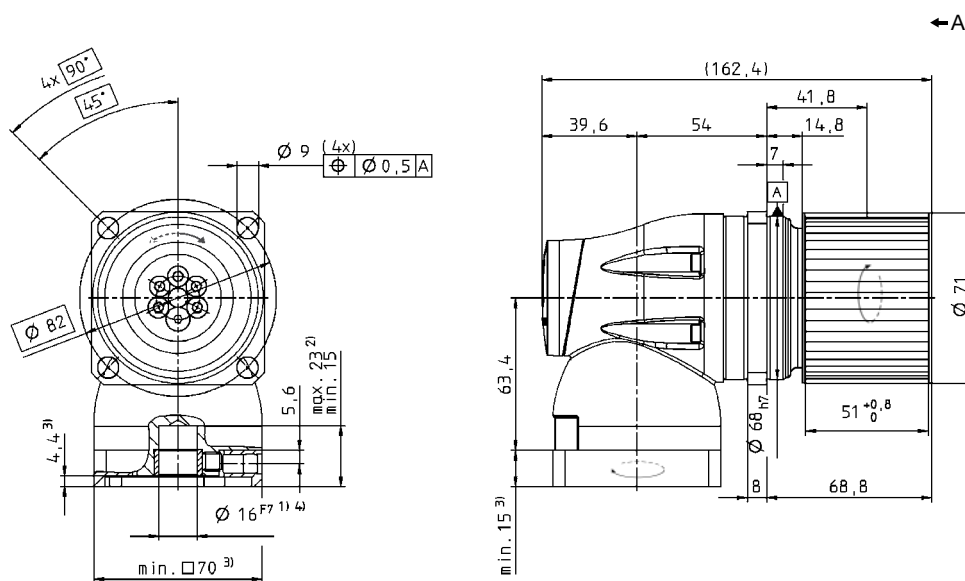

Accessory: Belt Pulley PLPB⁺ (not in the scope of delivery)

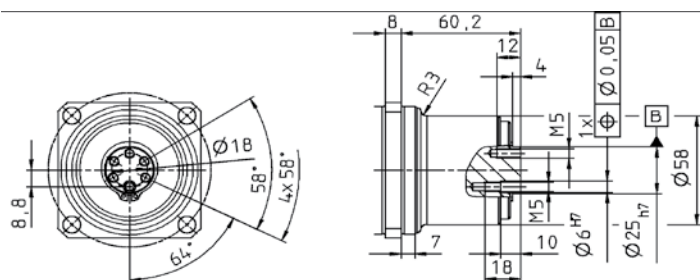

Belt Pulley PLPB ⁺ 070 Profile AT5-0			
Pitch	p	mm	5
Number of teeth	z		43
Circumference	$z * p$	mm/rotation	215
Inertia	J	kgcm ²	3.86
Mass	m	kg	0.48

Non-tolerated dimensions ± 1 mm

- 1) Check motor shaft fit.
- 2) Min./Max. permissible motor shaft length. Longer motor shafts are adaptable, please contact us.
- 3) The dimensions depend on the motor.
- 4) Smaller motor shaft diameter is compensated by a bushing.

Motor mounting according to operating manual



LPK+ 090 2/3-stage

Ratio	<i>i</i>	2-stage					3-stage									
		3	4	5	7	10	15	16	20	25	30	35	50	70	100	
Max. acceleration torque (max. 1000 cycles per hour)	T_{2B}	Nm	56	74	90	90	80	80	90	90	90	80	90	90	80	80
		in.lb	500	650	800	800	710	710	800	800	800	710	800	800	800	710
Nominal output torque (with n_{1N})	T_{2N}	Nm	28	37	45	45	40	40	45	45	45	40	45	45	40	40
		in.lb	250	330	400	400	350	350	400	400	400	400	400	400	400	350
Emergency stop torque (permitted 1000 times during the service life of the gearhead)	T_{2Not}	Nm	110	150	190	190	190	190	190	190	190	190	190	190	190	190
		in.lb	970	1330	1680	1680	1680	1680	1680	1680	1680	1680	1680	1680	1680	1680
Nominal input speed (with T_{2N} and 20°C ambient temperature ^{a)})	n_{1N}	rpm	2700	2700	2700	2700	2700	2700	2700	2700	2700	2700	2700	2700	2700	
Max. input speed	n_{1Max}	rpm	4000	4000	4000	4000	4000	4000	4000	4000	4000	4000	4000	4000	4000	
Mean no load running torque (with $n_1 = 3000$ rpm and 20°C gearhead temperature)	T_{012}	Nm	1.3	1.3	1.2	1.1	1.1	1.1	1.1	1.1	1.1	1.1	1.1	1.1	1.1	1.0
		in.lb	12	11	11	10	10	10	10	10	10	10	10	10	10	9
Max. torsional backlash	j_t	arcmin	≤ 14	≤ 12	≤ 12	≤ 11	≤ 10	≤ 11								
Torsional rigidity	C_{t21}	Nm/arcmin	4.9	6.5	7.3	8.2	8.0	8.3	9.2	9.4	9.4	8.4	9.5	9.5	9.5	8.5
		in.lb/arcmin	43	58	65	73	71	73	81	83	83	74	84	84	84	75
Max. axial force ^{b)}	F_{2AMax}	N	1900					1900								
		lb _f	430					430								
Max. radial force ^{b)}	F_{2RMax}	N	2400					2400								
		lb _f	540					540								
Efficiency at full load	η	%	92					90								
Service life (For calculation, see the Chapter "Information")	L_n	h	> 20000					> 20000								
Weight incl. standard adapter plate	m	kg	6.9					7.9								
		lb _m	15					17								
Operating noise (with $n_1 = 3000$ rpm no load)	L_{PA}	dB(A)	≤ 76													
Max. permitted housing temperature		°C	+90													
		F	194													
Ambient temperature		°C	-15 to 40													
		F	5 to 104													
Lubrication		Lubricated for life														
Paint		Blue RAL 5002														
Direction of rotation		Motor and gearhead same direction														
Protection class		IP 64														
Moment of inertia (relates to the drive)	J_f	kgcm ²	4.1	4.1	4.1	4.1	4.1	4.1	4.1	4.1	4.1	4.1	4.1	4.1	4.1	4.1
		10 ⁻² in.lb.s ²	3.6	3.6	3.6	3.6	3.6	3.6	3.6	3.6	3.6	3.6	3.6	3.6	3.6	3.6

^{a)} For higher ambient temperatures, please reduce input speed

^{b)} Refers to center of the output shaft, if $n_2 = 100$ rpm

2-stage:

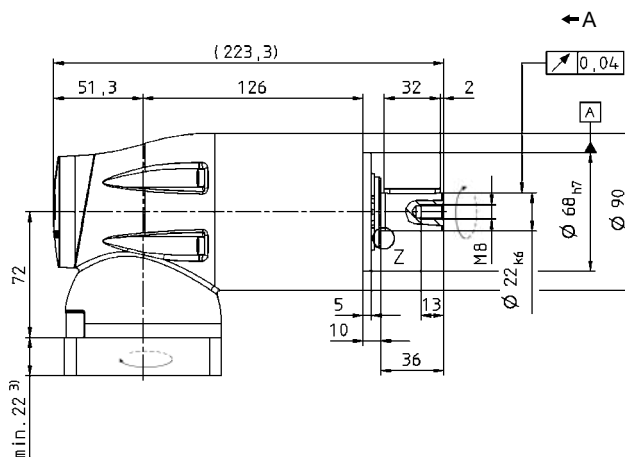
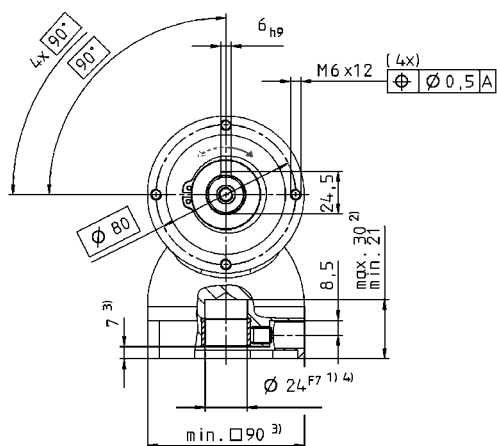

3-stage:

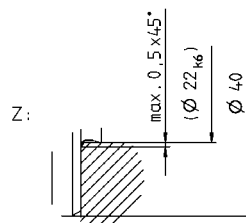
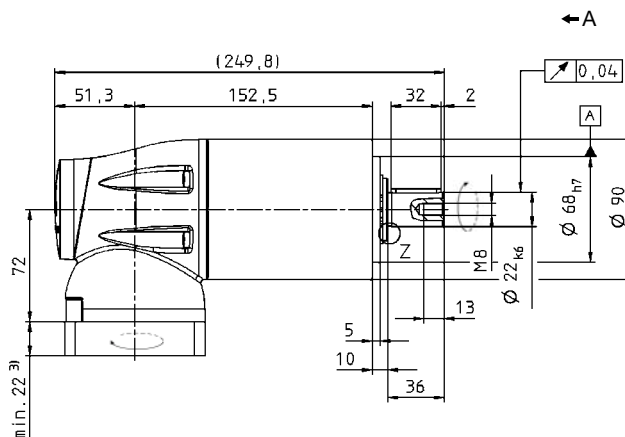
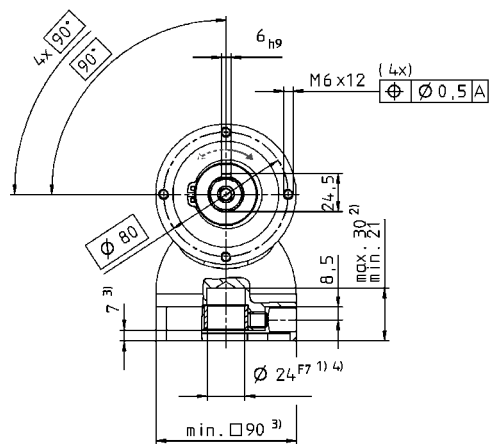

Non-tolerated dimensions ± 1 mm

- 1) Check motor shaft fit.
- 2) Min./Max. permissible motor shaft length. Longer motor shafts are adaptable, please contact us.
- 3) The dimensions depend on the motor.
- 4) Smaller motor shaft diameter is compensated by a bushing.

Motor mounting according to operating manual



LK/LPK/LPBK

LPBK+ 090 2-stage

		2-stage					
Ratio	<i>i</i>	3	4	5	7	10	
Max. acceleration torque (max. 1000 cycles per hour)	T_{2B}	Nm	56	74	90	90	80
		in.lb	500	650	800	800	710
Nominal output torque (with n_{1N})	T_{2N}	Nm	28	37	45	45	40
		in.lb	250	330	400	400	350
Emergency stop torque (permitted 1000 times during the service life of the gearhead)	T_{2Not}	Nm	110	150	190	190	190
		in.lb	970	1330	1680	1680	1680
Nominal input speed (with T_{2N} and 20°C ambient temperature ^{a)})	n_{1N}	rpm	2700	2700	2700	2700	2700
Max. input speed	n_{1Max}	rpm	4000	4000	4000	4000	4000
Mean no load running torque (with $n_1 = 3000$ rpm and 20°C gearhead temperature)	T_{012}	Nm	1.3	1.3	1.2	1.1	1.1
		in.lb	12	11	11	10	10
Max. torsional backlash	j_t	arcmin	≤ 14	≤ 12	≤ 12	≤ 11	≤ 10
Torsional rigidity	C_{t21}	Nm/arcmin	–	–	–	–	–
		in.lb/arcmin	–	–	–	–	–
Max. axial force ^{b)}	F_{2AMax}	N	1900				
		lb _f	430				
Max. radial force ^{c)}	F_{2RMax}	N	4300				
		lb _f	970				
Efficiency at full load	η	%	92				
Service life (For calculation, see the Chapter "Information")	L_n	h	> 20000				
Weight incl. standard adapter plate	m	kg	6.2				
		lb _m	14				
Operating noise (with $n_1 = 3000$ rpm no load)	L_{PA}	dB(A)	≤ 76				
Max. permitted housing temperature		°C					
		F	194				
Ambient temperature		°C	-15 to 40				
		F	5 to 104				
Lubrication			Lubricated for life				
Paint			Blue RAL 5002				
Direction of rotation			Motor and gearhead same direction				
Protection class			IP 64				
Moment of inertia (relates to the drive)	J_i	kgcm ²	4.1	4.1	4.1	4.1	4.1
		10 ⁻² in.lb.s ²	3.6	3.6	3.6	3.6	3.6

^{a)} For higher ambient temperatures, please reduce input speed

^{b)} Refers to center of the output shaft, if $n_2 = 100$ rpm

^{c)} With mounted PLPB+ belt pulley and 100 rpm

2-stage:

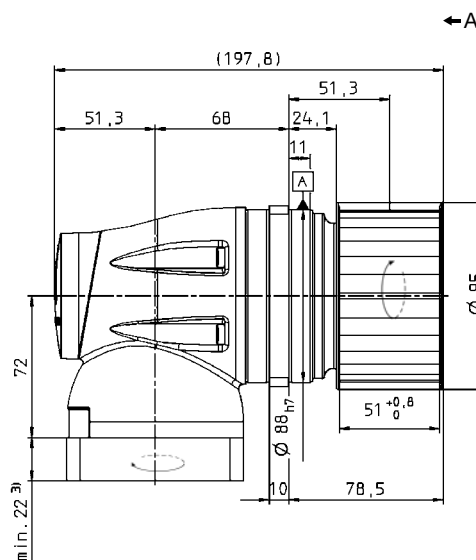
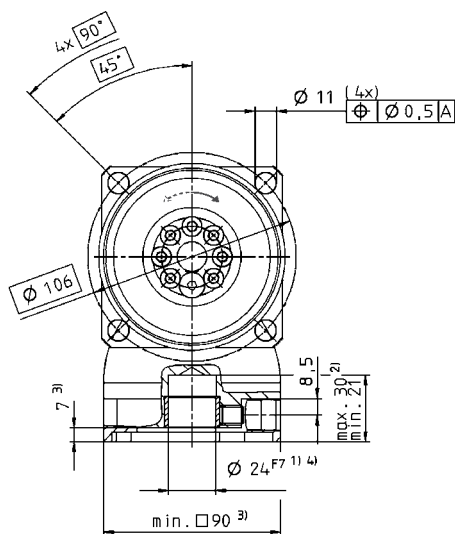
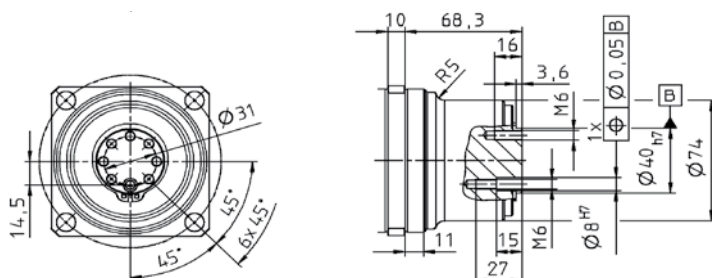
 Accessory: Belt Pulley PLPB⁺ (not in the scope of delivery)

Belt Pulley PLPB ⁺ 090 Profile AT10-0			
Pitch	p	mm	10
Number of teeth	z		28
Circumference	$z * p$	mm/rotation	280
Inertia	J	kgcm ²	10.95
Mass	m	kg	0.82

 Non-tolerated dimensions ± 1 mm

- 1) Check motor shaft fit.
- 2) Min./Max. permissible motor shaft length. Longer motor shafts are adaptable, please contact us.
- 3) The dimensions depend on the motor.
- 4) Smaller motor shaft diameter is compensated by a bushing.

Motor mounting according to operating manual



LPK+ 120 2/3-stage

Ratio	<i>i</i>	2-stage					3-stage										
		3	4	5	7	10	15	16	20	25	30	35	50	70	100		
Max. acceleration torque (max. 1000 cycles per hour)	T_{2B}	Nm	136	181	220	220	200	200	220	220	220	220	200	220	220	200	
		in.lb	1200	1600	1950	1950	1770	1770	1950	1950	1950	1950	1770	1950	1950	1950	1770
Nominal output torque (with n_{1N})	T_{2N}	Nm	68	91	110	110	100	100	110	110	110	100	110	110	110	100	
		in.lb	600	810	970	970	890	890	970	970	970	890	970	970	970	890	
Emergency stop torque (permitted 1000 times during the service life of the gearhead)	T_{2Not}	Nm	280	380	480	480	480	480	480	480	480	480	480	480	480	480	
		in.lb	2500	3400	4200	4200	4200	4200	4200	4200	4200	4200	4200	4200	4200	4200	
Nominal input speed (with T_{2N} and 20°C ambient temperature ^{a)})	n_{1N}	rpm	2100	2100	2100	2100	2100	2100	2100	2100	2100	2100	2100	2100	2100		
Max. input speed	n_{1Max}	rpm	3500	3500	3500	3500	3500	3500	3500	3500	3500	3500	3500	3500	3500		
Mean no load running torque (with $n_1 = 3000$ rpm and 20°C gearhead temperature)	T_{012}	Nm	3.5	3.3	3.2	3.1	3.1	2.9	2.9	2.8	2.8	2.7	2.7	2.7	2.7	2.7	
		in.lb	31	29	28	27	27	26	26	25	25	24	24	24	24	24	
Max. torsional backlash	j_t	arcmin	≤ 12	≤ 11	≤ 11	≤ 10	≤ 10	≤ 11									
Torsional rigidity	C_{t21}	Nm/arcmin	19	22	23	24	22	22	25	25	25	22	25	25	25	22	
		in.lb/arcmin	170	190	210	210	190	190	220	220	220	190	220	220	220	190	
Max. axial force ^{b)}	F_{2AMax}	N	4000					4000									
		lb _f	900					900									
Max. radial force ^{b)}	F_{2RMax}	N	4600					4600									
		lb _f	1040					1040									
Efficiency at full load	η	%	92					90									
Service life (For calculation, see the Chapter "Information")	L_n	h	> 20000					> 20000									
Weight incl. standard adapter plate	m	kg	17					19									
		lb _m	37					42									
Operating noise (with $n_1 = 3000$ rpm no load)	L_{PA}	dB(A)	≤ 76														
Max. permitted housing temperature		°C	+90														
		F	194														
Ambient temperature		°C	-15 to 40														
		F	5 to 104														
Lubrication			Lubricated for life														
Paint			Blue RAL 5002														
Direction of rotation			Motor and gearhead same direction														
Protection class			IP 64														
Moment of inertia (relates to the drive)	J_i	kgcm ²	17	17	17	17	17	17	17	17	17	17	17	17	17	17	
		10 ⁻² in.lb.s ²	15	15	15	15	15	15	15	15	15	15	15	15	15	15	

^{a)} For higher ambient temperatures, please reduce input speed

^{b)} Refers to center of the output shaft, if $n_2 = 100$ rpm

2-stage:

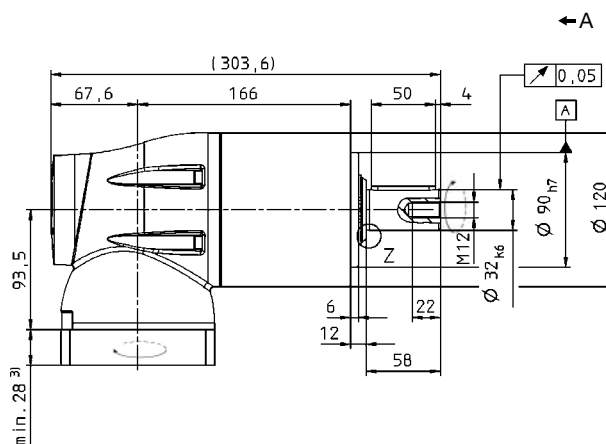
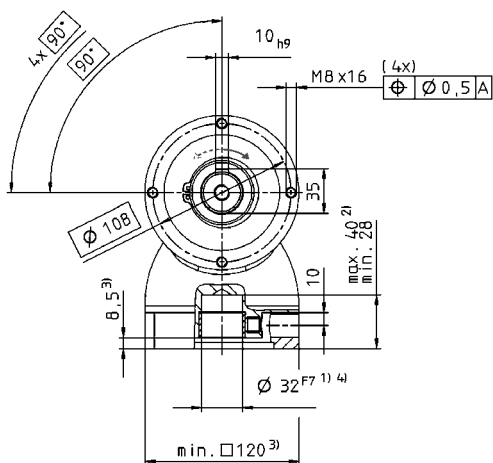

3-stage:

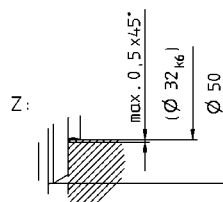
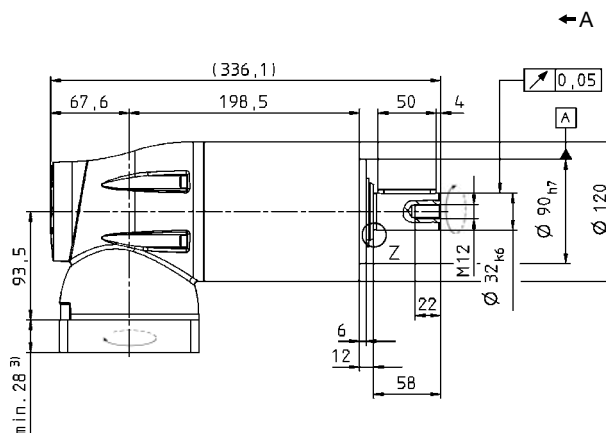
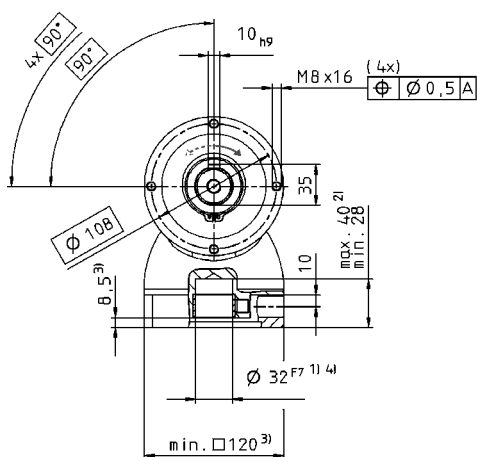

Non-tolerated dimensions ± 1 mm

- 1) Check motor shaft fit.
- 2) Min./Max. permissible motor shaft length. Longer motor shafts are adaptable, please contact us.
- 3) The dimensions depend on the motor.
- 4) Smaller motor shaft diameter is compensated by a bushing.

Motor mounting according to operating manual



LK-/LPK-
LPBK-

LPBK+ 120 2-stage

		2-stage					
Ratio	<i>i</i>	3	4	5	7	10	
Max. acceleration torque (max. 1000 cycles per hour)	T_{2B}	Nm	136	181	220	220	200
		in.lb	1200	1600	1950	1950	1770
Nominal output torque (with n_{1N})	T_{2N}	Nm	68	91	110	110	100
		in.lb	600	810	970	970	890
Emergency stop torque (permitted 1000 times during the service life of the gearhead)	T_{2Not}	Nm	280	380	480	480	480
		in.lb	2500	3400	4200	4200	4200
Nominal input speed (with T_{2N} and 20°C ambient temperature ^{a)})	n_{1N}	rpm	2100	2100	2100	2100	2100
Max. input speed	n_{1Max}	rpm	3500	3500	3500	3500	3500
Mean no load running torque (with $n_1=3000$ rpm and 20°C gearhead temperature)	T_{012}	Nm	3,5	3,3	3,2	3,1	3,1
		in.lb	31	29	28	27	27
Max. torsional backlash	j_t	arcmin	≤ 12	≤ 11	≤ 11	≤ 10	≤ 10
Torsional rigidity	C_{t21}	Nm/arcmin	-	-	-	-	-
		in.lb/arcmin	-	-	-	-	-
Max. axial force ^{b)}	F_{2AMax}	N	4000				
		lb _f	900				
Max. radial force ^{c)}	F_{2RMax}	N	9500				
		lb _f	2100				
Efficiency at full load	η	%	92				
Service life (For calculation, see the Chapter "Information")	L_n	h	> 20000				
Weight incl. standard adapter plate	m	kg	16				
		lb _m	34				
Operating noise (with $n_1=3000$ rpm no load)	L_{PA}	dB(A)	≤ 76				
Max. permitted housing temperature		°C	90				
		F	194				
Ambient temperature		°C	-15 to 40				
		F	5 to 104				
Lubrication			Lubricated for life				
Paint			Blue RAL 5002				
Direction of rotation			Motor and gearhead same direction				
Protection class			IP 64				
Moment of inertia (relates to the drive)	J_i	kgcm ²	17	17	17	17	17
		10 ⁻² in.lb.s ²	15	15	15	15	15

^{a)} For higher ambient temperatures, please reduce input speed

^{b)} Refers to center of the output shaft, if $n_2 = 100$ rpm

^{c)} With mounted PLPB+ belt pulley and 100 rpm

2-stage:

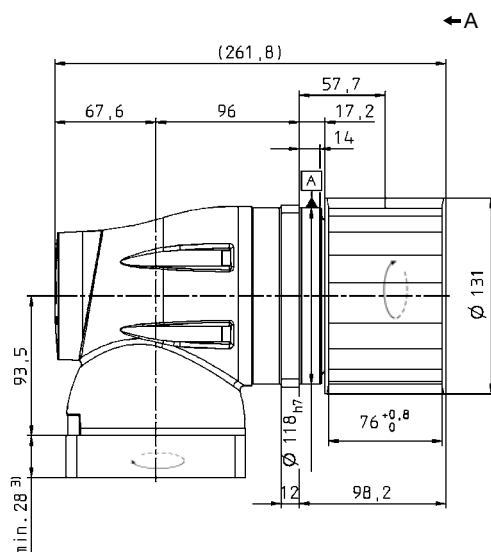
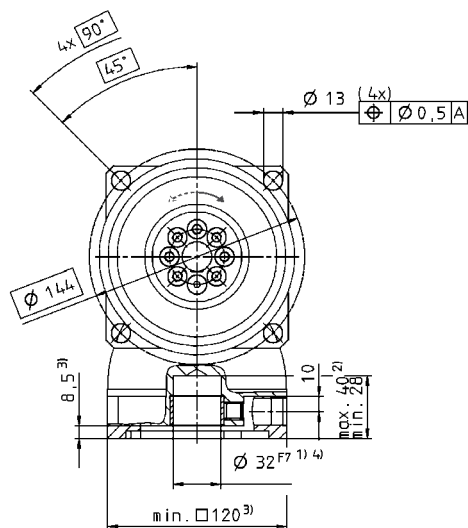

Accessory: Belt Pulley PLPB⁺ (not in the scope of delivery)

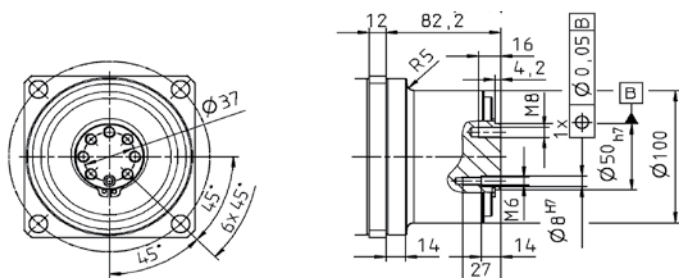

Belt Pulley PLPB ⁺ 120 Profile AT20-0			
Pitch	p	mm	20
Number of teeth	z		19
Circumference	$z * p$	mm/rotation	380
Inertia	J	kgcm ²	50.62
Mass	m	kg	2.61

Non-tolerated dimensions ± 1 mm

- 1) Check motor shaft fit.
- 2) Min./Max. permissible motor shaft length. Longer motor shafts are adaptable, please contact us.
- 3) The dimensions depend on the motor.
- 4) Smaller motor shaft diameter is compensated by a bushing.

Motor mounting according to operating manual



LPK+ 155 2/3-stage

Ratio	<i>i</i>		2-stage		3-stage		
			5	10	25	50	100
Max. acceleration torque (max. 1000 cycles per hour)	T_{2B}	Nm	450	350	450	450	350
		in.lb	4000	3100	4000	4000	3100
Nominal output torque (with n_{1N})	T_{2N}	Nm	320	190	320	320	190
		in.lb	2800	1700	2800	2800	1700
Emergency stop torque (permitted 1000 times during the service life of the gearhead)	T_{2Not}	Nm	1000	1000	1000	1000	1000
		in.lb	8850	8850	8850	8850	8850
Nominal input speed (with T_{2N} and 20°C ambient temperature ^{a)})	n_{1N}	rpm	1600	1600	1600	1600	1600
Max. input speed	n_{1Max}	rpm	3000	3000	3500	3500	3500
Mean no load running torque (with $n_1=3000$ rpm and 20°C gearhead temperature)	T_{012}	Nm	7.3	7.0	3.5	3.3	3.2
		in.lb					
Max. torsional backlash	j_t	arcmin	≤ 10	≤ 9	≤ 11		
Torsional rigidity	C_{t21}	Nm/arcmin	44	42	55	55	44
		in.lb/arcmin	390	370	480	490	390
Max. axial force ^{b)}	F_{2AMax}	N	6000		6000		
		lb _f	1350		1350		
Max. radial force ^{b)}	F_{2RMax}	N	7500		7500		
		lb _f	1690		1690		
Efficiency at full load	η	%	92		90		
Service life (For calculation, see the Chapter "Information")	L_n	h	> 20000		> 20000		
Weight incl. standard adapter plate	m	kg	35		39		
		lb _m	77		86		
Operating noise (with $n_1=3000$ rpm no load)	L_{PA}	dB(A)	≤ 78				
Max. permitted housing temperature			°C				
			+90				
Ambient temperature			°C				
			-15 to 40				
Lubrication			F				
			5 to 104				
Paint			Lubricated for life				
Direction of rotation			Blue RAL 5002				
Protection class			Motor and gearhead same direction				
Moment of inertia (relates to the drive)	J_f	kgcm ²	75	75	17	17	17
		10 ² in.lb.s ²	66	66	15	15	15

^{a)} For higher ambient temperatures, please reduce input speed

^{b)} Refers to center of the output shaft, if = 100 rpm

2-stage:

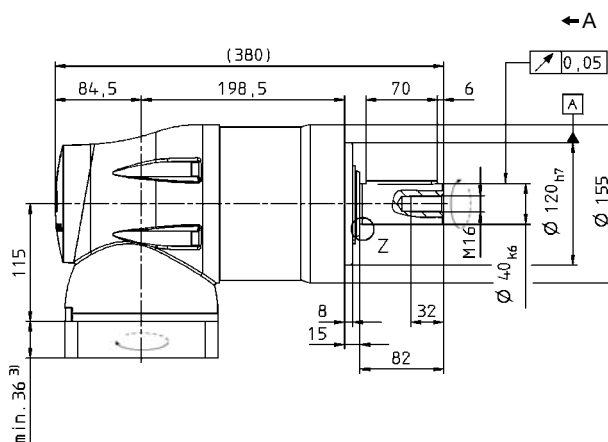
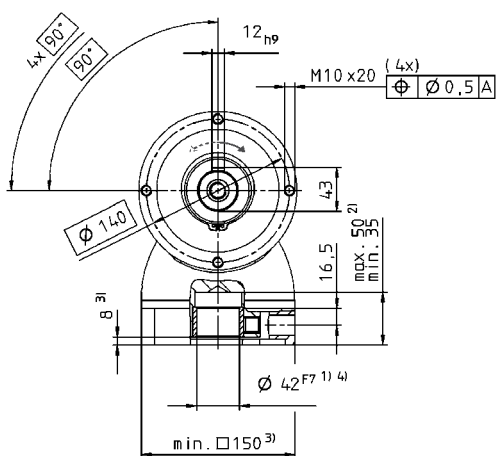

3-stage:

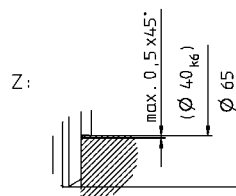
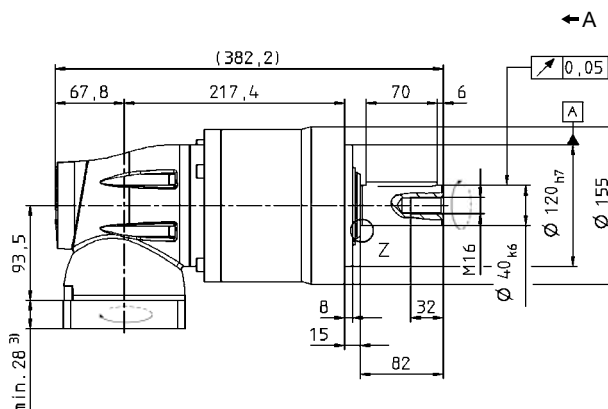
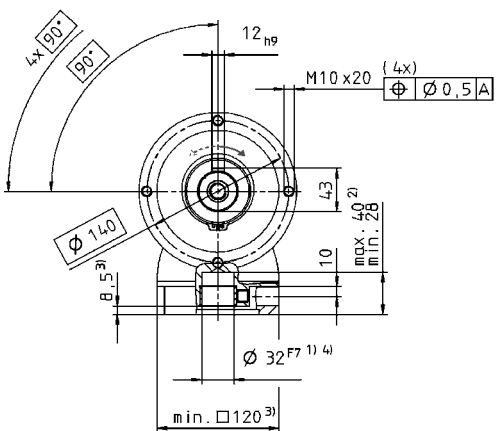

Non-tolerated dimensions ±1 mm

- 1) Check motor shaft fit.
- 2) Min./Max. permissible motor shaft length. Longer motor shafts are adaptable, please contact us.
- 3) The dimensions depend on the motor.
- 4) Smaller motor shaft diameter is compensated by a bushing.

Motor mounting according to operating manual



LK/LPK
LPBK

V-Drive⁺/V-Drive⁺ economy – The new generation of servo worm gearbox

The servo worm gearhead with solid shaft, hollow shaft and hollow shaft flange outputs



V-Drive⁺

Specifications \ Version	VDS ⁺ /VDT ⁺ /VDH ⁺ / VDS economy/VDH economy		
	+	++	+++
Positioning accuracy		[Progressive bar]	
Rigidity		VDT ⁺	[Progressive bar]
Smooth-running		VDS ⁺ /VDH ⁺	[Progressive bar]
Speed capacity		[Progressive bar]	
Power density		[Progressive bar]	
Max. axial/radial forces		[Progressive bar]	

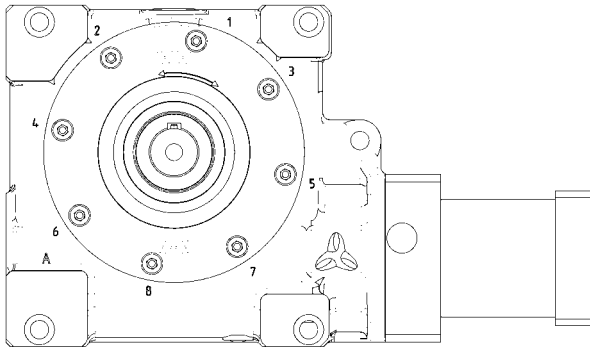

Combined with planetary gearbox for 2-stage



Shrink disc



Couplings

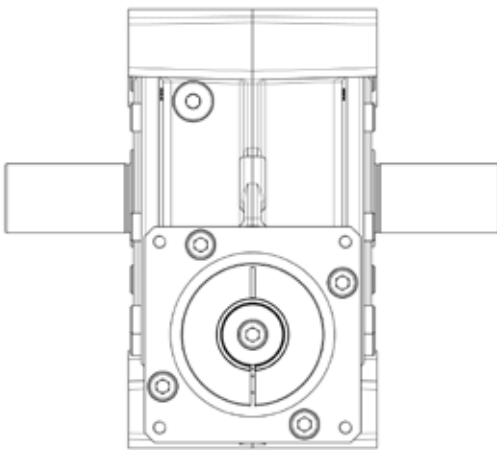

Shaft on both sides



Rack / Pinion

Options

VDS⁺, VDH⁺, VDT⁺ version
 VDS economy, VDH economy version
 Washdown version
 Food-grade grease 
 Shaft on both sides Shaft on both sides
 i > 40 (on request)

Accessories

Rack / Pinion (see page 310)
 Shrink disc (see page 342)
 Couplings (see page 342)

V-Drive®

A unique technology

Our new range of servo worm gear – the V-Drive® – offers unique variety for applications.

Through manufacturing process innovations, we are bringing the servo worm gear to a new level and offering two versions, the V-Drive+® and V-Drive® economy – to provide exceptional servo solutions.

Optimized hollow-flank teeth provide for constant positioning accuracy and low backlash, along with up to 50% more torque.

The V-Drive+® boasts 97% efficiency, the highest for servo worm gears on the market.

Our commitment to you is 100% delivery satisfaction along with the optional WITTENSTEIN alpha 72-hour delivery service.

Involute teeth

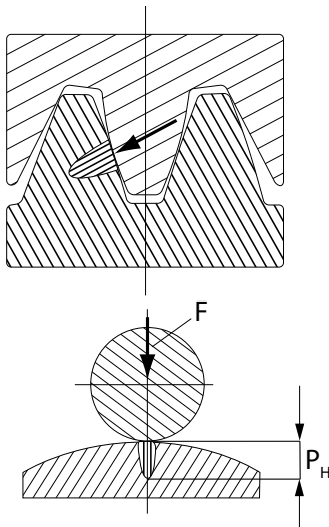

- High surface pressure = increased wear (pitting)
- Smaller tooth root thickness

Hollow-flank teeth with V-Drive®

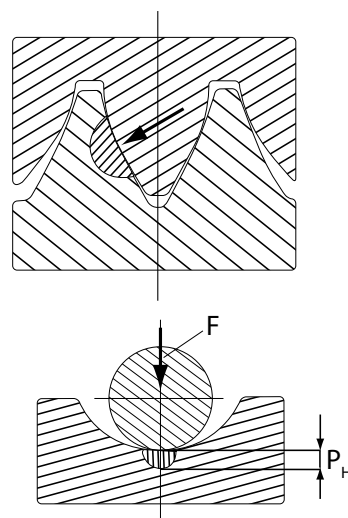

- Low surface pressure = reduced wear (no pitting)
- Larger tooth root thickness = high load and overload capacity

A new design philosophy

for servo worm gears

To meet the needs for a variety of applications requiring servo worm gears, WITTENSTEIN alpha has developed a revolutionary new design philosophy.

The transmittable torque is arranged into two types:

T_{2Max}

T_{2Max} means the maximum torque which can be transmitted by the gearbox.

This value can be chosen for applications that can accept a slight increase in backlash over time.

T_{2Servo}

T_{2Servo} is a special value for precision applications in which a minimum backlash must be guaranteed over the life of the gearbox. The increase in backlash seen in other worm gears is less due to the optimized hollow flank teeth.



V-Drive+®

The plus stands for torque

With continuously high positioning accuracy and low backlash of <3 arcmin, the V-Drive+® sets new standards for servo worm gears. These outstanding characteristics create an optimal symbiosis between power and precision.

VDT+
shaft flange

VDS+
shaft, smooth/
keyed/
involute

The following output options
are available:

- VDH (hollow shaft, smooth/keyed)
- VDS (shaft, smooth/keyed/involute)
- VDT (shaft flange)

Sizes 050, 063, 080, 100

VDH+
hollow shaft,
smooth/
keyed

Features:

Ratio 4, 7, 10, 16, 28, 40
Torsional backlash < 3 arcmin
Efficiency of up to 97%



Revolutionary teeth technology for 50% more torque!

V-Drive® economy

Highest quality with maximum results

With the V-Drive® economy, an economical solution has been created for low-duty applications. WITTENSTEIN quality combined with optimized hollow-flank teeth provides more torque and power density than comparable products.

The following output options are available:

- VDH (hollow shaft, smooth/keyed)
- VDS (shaft, smooth/keyed)

Sizes 050, 063

Features:

Ratio 7, 10, 16, 28, 40

Torsional backlash < 8 arcmin

VDH economy

hollow shaft
smooth/keyed

VDS economy

shaft
smooth/keyed



Optimal performance for low-duty applications!

VDT+ 050 1-stage

			1-stage					
Ratio	<i>i</i>		4	7	10	16	28	40
$n_{IN}=500$ rpm	T_{2Max}	Nm	124	132	148	154	165	158
		in.lb	1097	1168	1310	1363	1460	1398
	T_{2Servo}	Nm	54	71	74	81	90	74
		in.lb	478	628	655	717	797	655
η	%		92	89	86	82	72	64
$n_{IN}=1000$ rpm	T_{2Max}	Nm	124	130	136	140	151	142
		in.lb	1097	1151	1204	1239	1336	1257
	T_{2Servo}	Nm	58	76	80	88	97	81
		in.lb	513	673	708	779	858	717
η	%		94	91	89	85	77	69
$n_{IN}=2000$ rpm	T_{2Max}	Nm	88	106	112	120	134	122
		in.lb	779	938	991	1062	1186	1080
	T_{2Servo}	Nm	60	78	82	89	99	83
		in.lb	531	690	726	788	876	735
η	%		95	93	91	88	75	75
$n_{IN}=3000$ rpm	T_{2Max}	Nm	72	86	95	106	112	108
		in.lb	637	761	841	938	991	956
	T_{2Servo}	Nm	59	77	81	88	97	81
		in.lb	522	681	717	779	858	717
η	%		96	94	93	90	83	78
$n_{IN}=4000$ rpm	T_{2Max}	Nm	62	77	83	92	102	95
		in.lb	549	681	735	814	903	841
	T_{2Servo}	Nm	58	76	79	87	96	80
		in.lb	513	673	699	770	850	708
η	%		96	95	93	91	85	80
Emergency stop torque	T_{2Not}	Nm	230	242	242	250	262	236
		in.lb	2036	2142	2142	2213	2319	2089
Max. input speed	n_{1Max}	rpm	6000					
Mean no load running torque ^{a)} <small>(With $n_{IN}=3000$ min⁻¹ and 20° C gear temperature)</small>	T_{012}	Nm	1,3	1,2	1,2	1,1	1	0,9
		in.lb	11,5	10,6	10,6	9,7	8,9	8,0
Max. torsional backlash	j_t	arcmin	≤3					
Torsional rigidity	C_{t21}	Nm/arcmin	17					
		in.lb/arcmin	150					
Max. axial force ^{b)}	F_{2AMax}	N	5000					
		lb _f	1125					
Max. radial force ^{b)}	F_{2RMMax}	N	3800					
		lb _f	855					
Max. tilting moment	M_{2KMMax}	Nm	409					
		in.lb	3620					
Tilting rigidity	C_{2K}	Nm/arcmin	504					
		in.lb/arcmin	4460					
Service life <small>(For calculation see "Information")</small>	L_h	h	> 20000					
Weight <small>(without motor attachment parts)</small>	m	kg	8,8					
		lb _m	19,4					
Operating noise <small>(with $n_{IN}=3000$ rpm no load)</small>	L_{PA}	dB(A)	≤ 62					
Max. permitted housing temperature		°C	+90					
		F	194					
Ambient temperature		°C	-15 to +40					
		F	5 to 104					
Lubrication	Synthetic transmission oil							
Paint	None							
Direction of rotation	See drawing							
Protection class	IP 65							
Moment of inertia <small>(relates to the drive)</small>	J_1	kgcm ²	2,59	2,12	1,98	1,86	1,82	1,86
		10 ⁻³ in.lb.s ²	2,29	1,87	1,75	1,64	1,61	1,65

^{a)} Idling torques decrease during operation

^{b)} Refers to center of the output shaft or flange

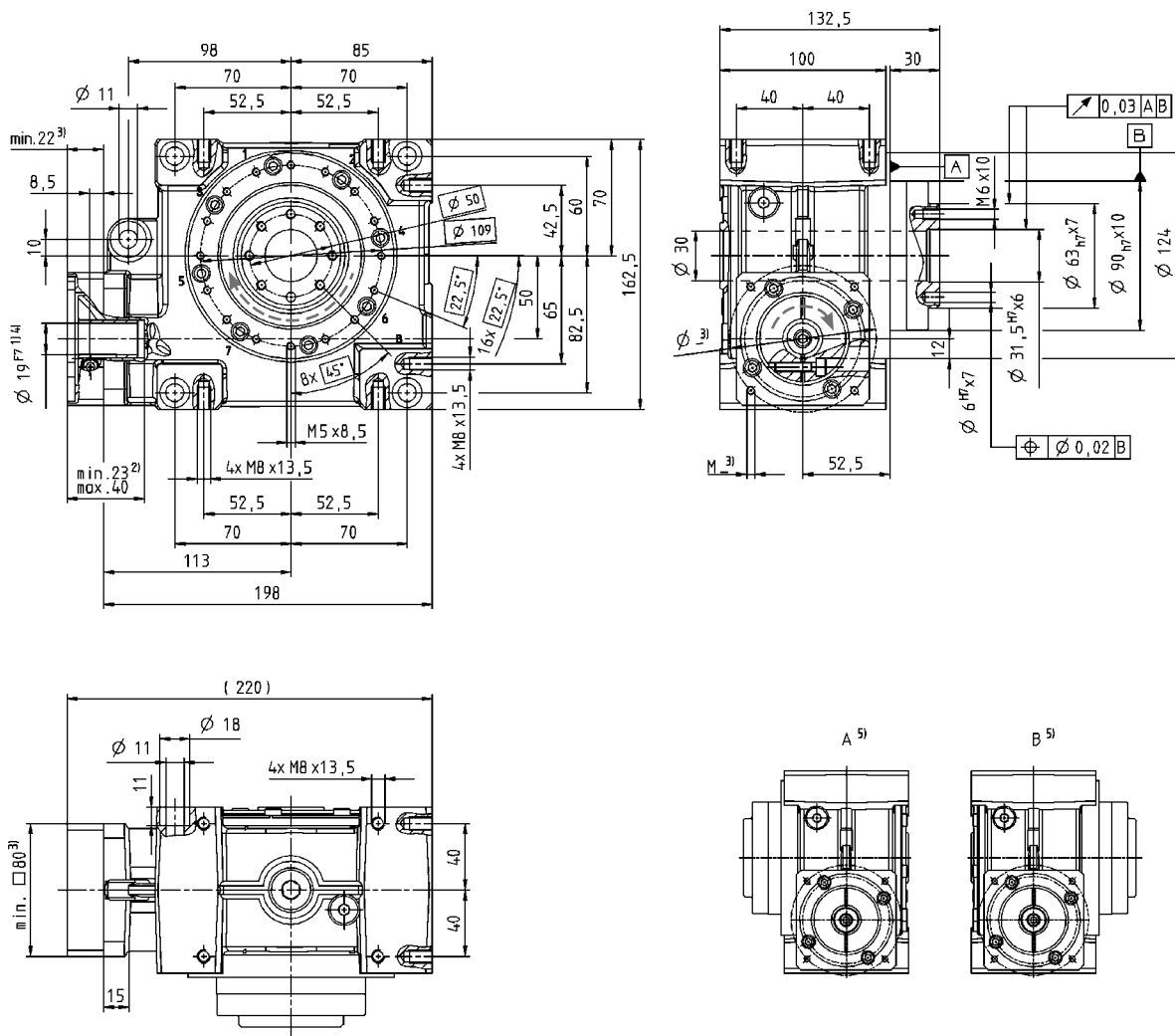

Non-tolerated dimensions ± 1 mm

- 1) Check motor shaft fit.
- 2) Min./Max. permissible motor shaft length.
Longer motor shafts are adaptable, please contact us.
- 3) The dimensions depend on the motor.
- 4) Smaller motor shaft diameter is compensated by a bushing with a minimum thickness of 1 mm.
- 5) Output side

⚠ Motor mounting according to operating manual



VDT+ 063 1-stage

			1-stage					
Ratio	<i>i</i>		4	7	10	16	28	40
$n_{IN}=500$ rpm	T_{2Max}	Nm	302	314	315	320	328	324
		in.lb	2673	2779	2788	2832	2903	2867
	T_{2Servo}	Nm	198	210	225	221	229	226
		in.lb	1752	1859	1991	1956	2027	2000
η	%		93	91	88	83	74	68
$n_{IN}=1000$ rpm	T_{2Max}	Nm	264	284	290	298	304	301
		in.lb	2336	2513	2567	2637	2690	2664
	T_{2Servo}	Nm	192	228	240	238	245	241
		in.lb	1699	2018	2124	2106	2168	2133
η	%		94	93	91	86	78	73
$n_{IN}=2000$ rpm	T_{2Max}	Nm	202	243	262	271	282	278
		in.lb	1788	2151	2319	2398	2496	2460
	T_{2Servo}	Nm	174	212	230	238	248	243
		in.lb	1540	1876	2036	2106	2195	2151
η	%		96	94	93	89	83	78
$n_{IN}=3000$ rpm	T_{2Max}	Nm	164	190	202	209	235	231
		in.lb	1451	1682	1788	1850	2080	2044
	T_{2Servo}	Nm	128	166	184	209	198	194
		in.lb	1133	1469	1628	1850	1752	1717
η	%		96	95	94	91	85	81
$n_{IN}=4000$ rpm	T_{2Max}	Nm	128	148	164	175	201	198
		in.lb	1133	1310	1451	1549	1779	1752
	T_{2Servo}	Nm	104	132	152	175	165	162
		in.lb	920	1168	1345	1549	1460	1434
η	%		97	96	94	92	86	83
Emergency stop torque	T_{2Not}	Nm	460	484	491	494	518	447
		in.lb	4071	4283	4345	4372	4584	3956
Max. input speed	n_{1Max}	rpm	4500					
Mean no load running torque ^{a)} <small>(With $n_{IN}=3000$ min⁻¹ and 20° C gear temperature)</small>	T_{012}	Nm	2,1	1,9	1,8	1,7	1,6	1,4
		in.lb	18,6	16,8	15,9	15,0	14,2	12,4
Max. torsional backlash	j_t	arcmin	≤3					
Torsional rigidity	C_{I21}	Nm/arcmin	50					
		in.lb/arcmin	443					
Max. axial force ^{b)}	F_{2AMax}	N	8250					
		lb _f	1856					
Max. radial force ^{b)}	F_{2RMax}	N	6000					
		lb _f	1350					
Max. tilting moment	M_{2KMMax}	Nm	843					
		in.lb	7461					
Tilting rigidity	C_{2K}	Nm/arcmin	603					
		in.lb/arcmin	5337					
Service life <small>(For calculation see "Information")</small>	L_h	h	> 20000					
Weight <small>(without motor attachment parts)</small>	m	kg	14,5					
		lb _m	32					
Operating noise <small>(with $n_{IN}=3000$ rpm no load)</small>	L_{PA}	dB(A)	≤ 64					
Max. permitted housing temperature		°C	+90					
		F	194					
Ambient temperature		°C	-15 to +40					
		F	5 to 104					
Lubrication	Synthetic transmission oil							
Paint	None							
Direction of rotation	See drawing							
Protection class	IP 65							
Moment of inertia <small>(relates to the drive)</small>	J_1	kgcm ²	7,45	6,02	5,65	5,49	5,42	5,36
		10 ⁻³ in.lb.s ²	6,60	5,33	5,00	4,86	4,80	4,75

^{a)} Idling torques decrease during operation

^{b)} Refers to center of the output shaft or flange

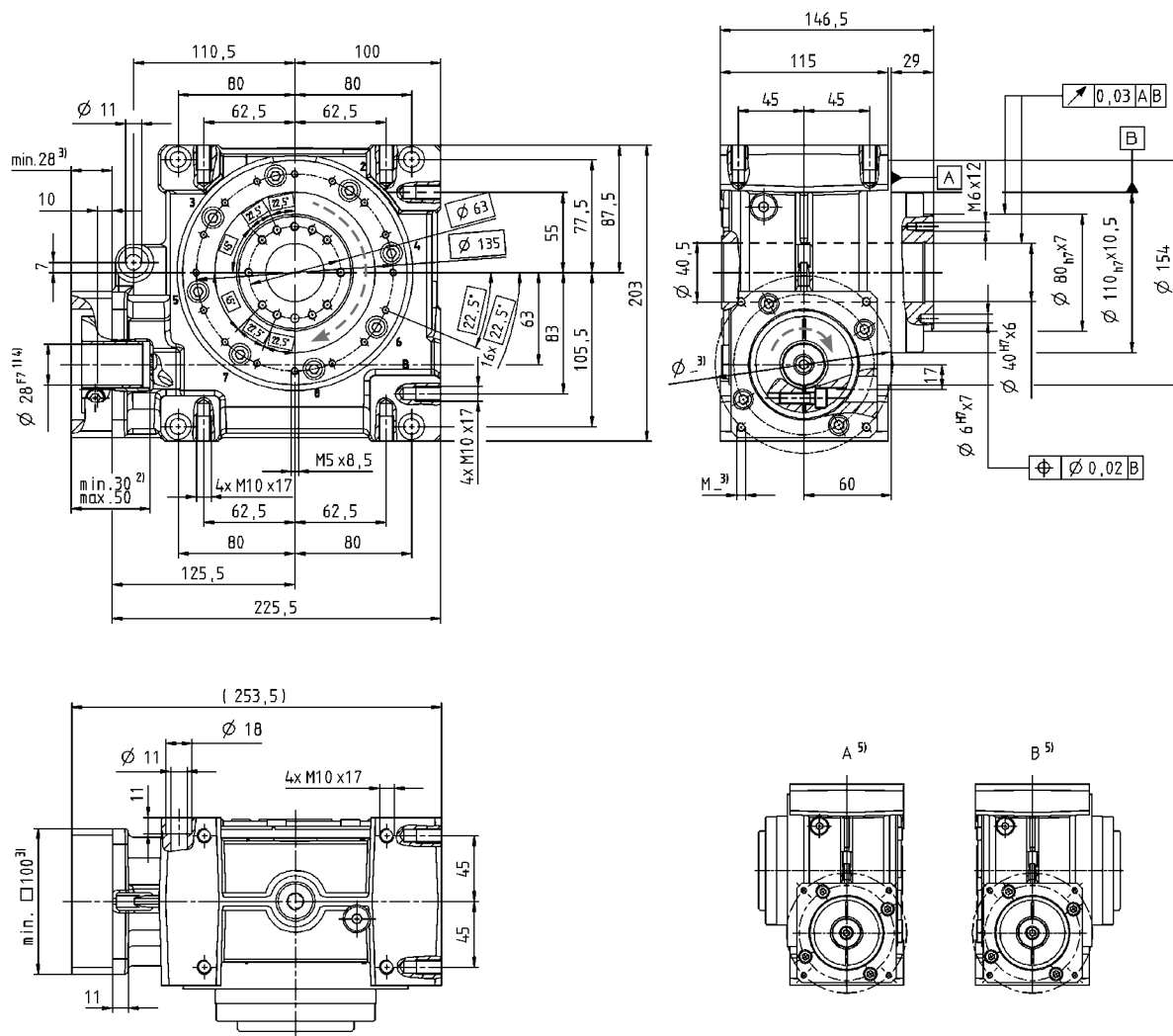

Non-tolerated dimensions ± 1 mm

- 1) Check motor shaft fit.
- 2) Min./Max. permissible motor shaft length.
Longer motor shafts are adaptable, please contact us.
- 3) The dimensions depend on the motor.
- 4) Smaller motor shaft diameter is compensated by a bushing with a minimum thickness of 1 mm.
- 5) Output side

 Motor mounting according to operating manual



VDT+ 080 1-stage

			1-stage					
Ratio	<i>i</i>		4	7	10	16	28	40
$n_{IN}=500$ rpm	T_{2Max}	Nm	578	646	672	702	785	676
		in.lb	5115	5717	5947	6213	6947	5983
	T_{2Servo}	Nm	469	601	613	677	764	631
		in.lb	4151	5319	5425	5991	6761	5584
η	%		94	92	89	86	77	70
$n_{IN}=1000$ rpm	T_{2Max}	Nm	514	602	588	656	698	613
		in.lb	4549	5328	5204	5806	6177	5425
	T_{2Servo}	Nm	491	574	561	625	665	584
		in.lb	4345	5080	4965	5531	5885	5168
η	%		95	93	91	88	81	74
$n_{IN}=2000$ rpm	T_{2Max}	Nm	350	435	431	500	536	470
		in.lb	3098	3850	3814	4425	4744	4160
	T_{2Servo}	Nm	335	415	411	476	511	448
		in.lb	2965	3673	3637	4213	4522	3965
η	%		96	95	93	89	84	79
$n_{IN}=3000$ rpm	T_{2Max}	Nm	259	336	334	400	433	380
		in.lb	2292	2974	2956	3540	3832	3363
	T_{2Servo}	Nm	247	320	319	381	413	362
		in.lb	2186	2832	2823	3372	3655	3204
η	%		97	96	94	92	86	81
$n_{IN}=3500$ rpm	T_{2Max}	Nm	227	299	300	362	394	346
		in.lb	2009	2646	2655	3204	3487	3062
	T_{2Servo}	Nm	217	285	286	345	376	330
		in.lb	1920	2522	2531	3053	3328	2921
η	%		97	96	94	92	87	82
Emergency stop torque	T_{2Not}	Nm	938	993	963	1005	1064	941
in.lb		8301	8788	8523	8894	9416	8328	
Max. input speed	n_{1Max}	rpm	4000					
Mean no load running torque ^{a)} <small>(With $n_{IN}=3000$ min⁻¹ and 20° C gear temperature)</small>	T_{012}	Nm	3,6	3,5	3,4	3,2	3	2,8
		in.lb	31,9	31,0	30,1	28,3	26,6	24,8
Max. torsional backlash	j_t	arcmin	≤3					
Torsional rigidity	C_{I21}	Nm/arcmin	113					
		in.lb/arcmin	1000					
Max. axial force ^{b)}	F_{2AMax}	N	13900					
		lb _f	3128					
Max. radial force ^{b)}	F_{2RMax}	N	9000					
		lb _f	2025					
Max. tilting moment	M_{2KMMax}	Nm	1544					
		in.lb	13664					
Tilting rigidity	C_{2K}	Nm/arcmin	1178					
		in.lb/arcmin	10425					
Service life <small>(For calculation see "Information")</small>	L_h	h	> 20000					
Weight <small>(without motor attachment parts)</small>	m	kg	31					
		lb _m	68,5					
Operating noise <small>(with $n_{IN}=3000$ rpm no load)</small>	L_{PA}	dB(A)	≤ 66					
Max. permitted housing temperature	°C		+90					
	F		194					
Ambient temperature	°C		-15 to +40					
	F		5 to 104					
Lubrication	Synthetic transmission oil							
Paint	None							
Direction of rotation	See drawing							
Protection class	IP 65							
Moment of inertia <small>(relates to the drive)</small>	J_1	kgcm ²	23,99	18,64	18,23	16,54	16,32	16,94
		10 ⁻³ in.lb.s ²	21,23	16,49	16,13	14,64	14,44	14,99

^{a)} Idling torques decrease during operation

^{b)} Refers to center of the output shaft or flange

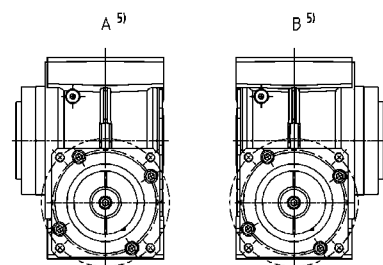
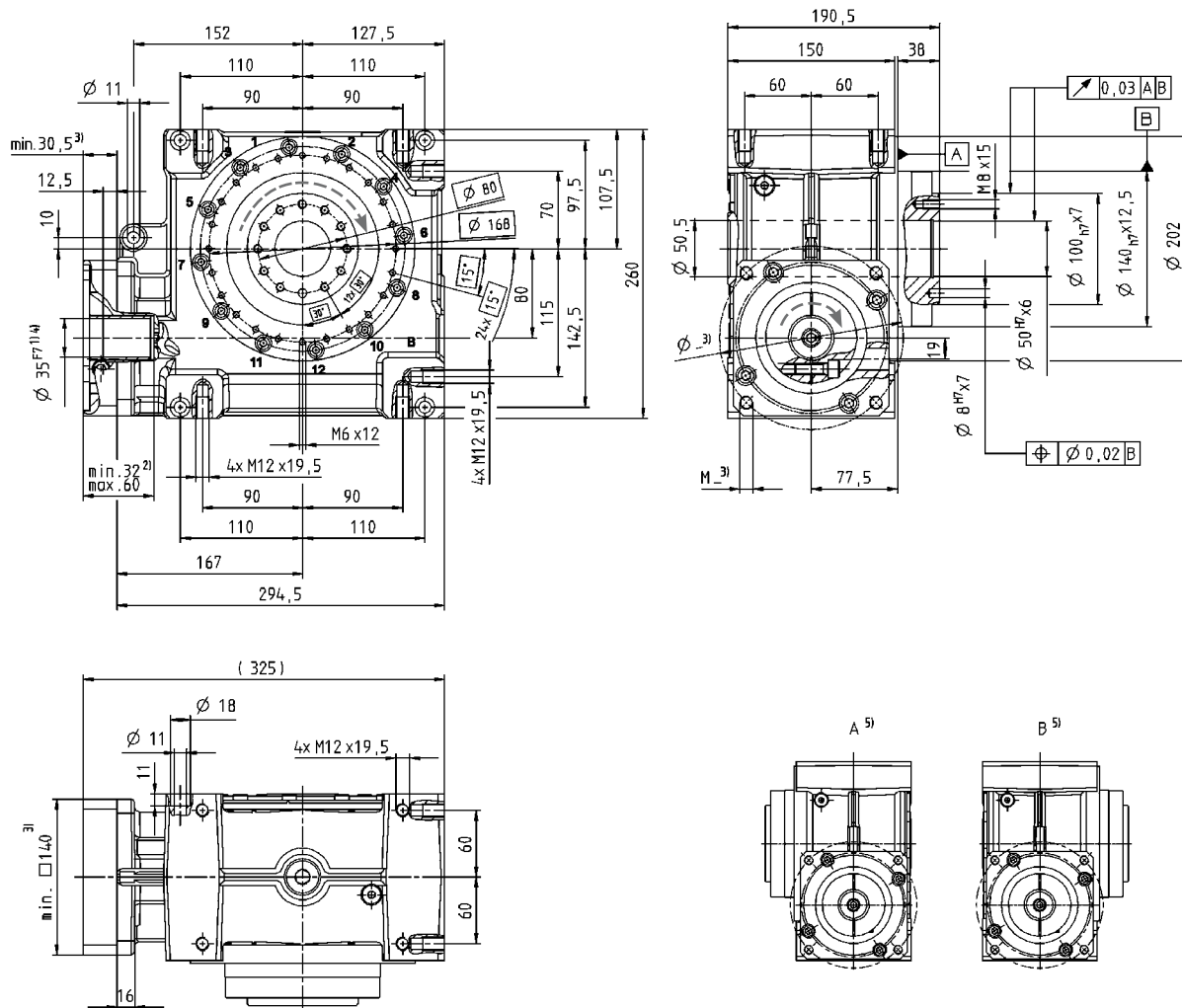

- Non-tolerated dimensions ± 1 mm
- 1) Check motor shaft fit.
 - 2) Min./Max. permissible motor shaft length.
Longer motor shafts are adaptable, please contact us.
 - 3) The dimensions depend on the motor.
 - 4) Smaller motor shaft diameter is compensated by a bushing with a minimum thickness of 1 mm.
 - 5) Output side

Motor mounting according to operating manual



VDT+ 100 1-stage

			1-stage					
Ratio	<i>i</i>		4	7	10	16	28	40
$n_{IN}=500$ rpm	T_{2Max}	Nm	1184	1336	1377	1392	1505	1376
		in.lb	10478	11824	12186	12319	13319	12178
	T_{2Servo}	Nm	1155	1304	1343	1359	1469	1343
		in.lb	10222	11540	11886	12027	13001	11886
η	%		95	93	91	87	80	76
$n_{IN}=1000$ rpm	T_{2Max}	Nm	905	1070	1122	1140	1251	1162
		in.lb	8009	9470	9930	10089	11071	10284
	T_{2Servo}	Nm	883	1044	1095	1113	1221	1134
		in.lb	7815	9239	9691	9850	10806	10036
η	%		95	94	92	88	82	79
$n_{IN}=2000$ rpm	T_{2Max}	Nm	595	748	807	830	930	883
		in.lb	5266	6620	7142	7346	8231	7815
	T_{2Servo}	Nm	581	730	788	810	908	862
		in.lb	5142	6461	6974	7169	8036	7629
η	%		96	95	94	91	86	82
$n_{IN}=3000$ rpm ^{c)}	T_{2Max}	Nm	430	564	621	644	735	709
		in.lb	3806	4991	5496	5699	6505	6275
	T_{2Servo}	Nm	420	551	606	629	718	692
		in.lb	3717	4876	5363	5567	6354	6124
η	%		97	96	95	92	87	84
$n_{IN}=3500$ rpm	T_{2Max}	Nm	-	-	-	-	-	-
		in.lb	-	-	-	-	-	-
	η	%		-	-	-	-	-
Emergency stop torque	T_{2Not}	Nm	1819	1932	1940	1955	2073	1856
		in.lb	16098	17098	17169	17302	18346	16426
Max. input speed	n_{1Max}	rpm	3500					
Mean no load running torque ^{a)} <small>(With $n_{IN}=3000$ min⁻¹ and 20° C gear temperature)</small>	T_{012}	Nm	9,8	8,1	7,4	6,7	5,8	5
		in.lb	86,7	71,7	65,5	59,3	51,3	44,3
Max. torsional backlash	j_t	arcmin	≤3					
Torsional rigidity	C_{121}	Nm/arcmin	213					
		in.lb/arcmin	1885					
Max. axial force ^{b)}	F_{2AMax}	N	19500					
		lb _f	4388					
Max. radial force ^{b)}	F_{2RMax}	N	14000					
		lb _f	3150					
Max. tilting moment	M_{2KMax}	Nm	3059					
		in.lb	27072					
Tilting rigidity	C_{2K}	Nm/arcmin	2309					
		in.lb/arcmin	20435					
Service life <small>(For calculation see "Information")</small>	L_h	h	> 20000					
Weight <small>(without motor attachment parts)</small>	m	kg	62					
		lb _m	137					
Operating noise <small>(with $n_{IN}=3000$ rpm no load)</small>	L_{PA}	dB(A)	≤ 70					
Max. permitted housing temperature		°C	+90					
		F	194					
Ambient temperature		°C	-15 to +40					
		F	5 to 104					
Lubrication	Synthetic transmission oil							
Paint	None							
Direction of rotation	See drawing							
Protection class	IP 65							
Moment of inertia <small>(relates to the drive)</small>	J_1	kgcm ²	83,51	64,27	59,95	59,40	56,32	56,49
		10 ⁻³ in.lb.s ²	73,90	56,88	53,06	52,56	49,85	50,00

^{a)} Idling torques decrease during operation

^{b)} Refers to center of the output shaft or flange

^{c)} Reduced by 20% in S1 operation

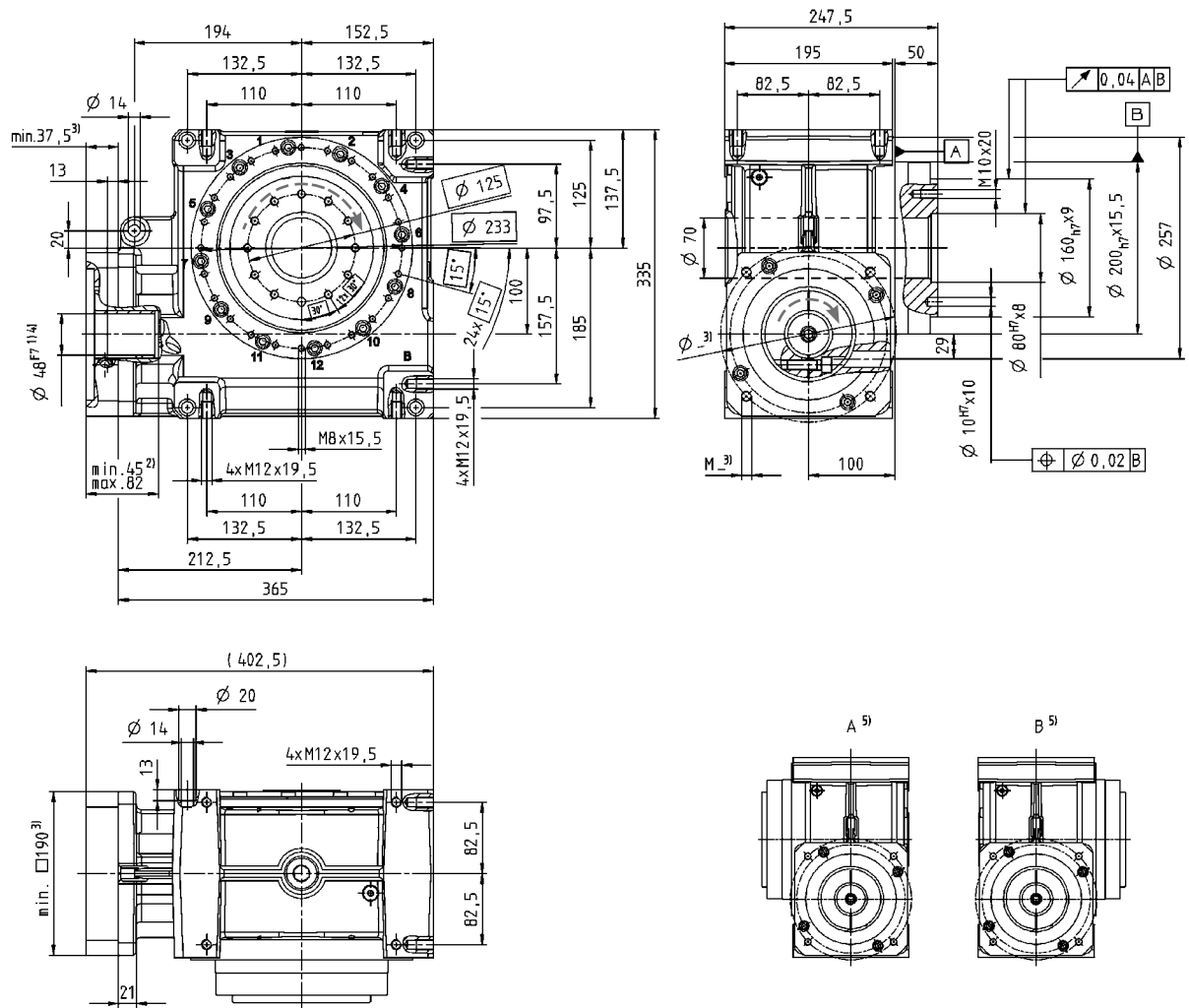

Non-tolerated dimensions ± 1 mm

- 1) Check motor shaft fit.
- 2) Min./Max. permissible motor shaft length.
Longer motor shafts are adaptable, please contact us.
- 3) The dimensions depend on the motor.
- 4) Smaller motor shaft diameter is compensated by a bushing with a minimum thickness of 1 mm.
- 5) Output side

Motor mounting according to operating manual



VDS+ 050 1-stage

			1-stage					
Ratio	<i>i</i>		4	7	10	16	28	40
$n_{IN}=500$ rpm	T_{2Max}	Nm	124	132	148	154	165	158
		in.lb	1097	1168	1310	1363	1460	1398
	T_{2Servo}	Nm	54	71	74	81	90	74
		in.lb	478	628	655	717	797	655
η	%		92	89	86	82	72	64
$n_{IN}=1000$ rpm	T_{2Max}	Nm	124	130	136	140	151	142
		in.lb	1097	1151	1204	1239	1336	1257
	T_{2Servo}	Nm	58	76	80	88	97	81
		in.lb	513	673	708	779	858	717
η	%		94	91	89	85	77	69
$n_{IN}=2000$ rpm	T_{2Max}	Nm	88	106	112	120	134	122
		in.lb	779	938	991	1062	1186	1080
	T_{2Servo}	Nm	60	78	82	89	99	83
		in.lb	531	690	726	788	876	735
η	%		95	93	91	88	75	75
$n_{IN}=3000$ rpm	T_{2Max}	Nm	72	86	95	106	112	108
		in.lb	637	761	841	938	991	956
	T_{2Servo}	Nm	59	77	81	88	97	81
		in.lb	522	681	717	779	858	717
η	%		96	94	93	90	83	78
$n_{IN}=4000$ rpm	T_{2Max}	Nm	62	77	83	92	102	95
		in.lb	549	681	735	814	903	841
	T_{2Servo}	Nm	58	76	79	87	96	80
		in.lb	513	673	699	770	850	708
η	%		96	95	93	91	85	80
Emergency stop torque	T_{2Not}	Nm	230	242	242	250	262	236
		in.lb	2036	2142	2142	2213	2319	2089
Max. input speed	n_{1Max}	rpm	6000					
Mean no load running torque ^{a)} <small>(With $n_{IN}=3000$ min⁻¹ and 20° C gear temperature)</small>	T_{012}	Nm	1,3	1,2	1,2	1,1	1	0,9
		in.lb	11,5	10,6	10,6	9,7	8,9	8,0
Max. torsional backlash	j_t	arcmin	≤3					
Torsional rigidity	C_{121}	Nm/arcmin	8					
		in.lb/arcmin	71					
Max. axial force ^{b)}	F_{2AMax}	N	5000					
		lb _f	1125					
Max. radial force ^{b)}	F_{2RMMax}	N	3800					
		lb _f	855					
Max. tilting moment	M_{2KMMax}	Nm	409					
		in.lb	3620					
Service life <small>(For calculation see "Information")</small>	L_h	h	> 20000					
Weight <small>(without motor attachment parts)</small>	m	kg	8,5					
		lb _m	18,8					
Operating noise <small>(with $n_{IN}=3000$ rpm no load)</small>	L_{PA}	dB(A)	≤ 62					
Max. permitted housing temperature	°C		+90					
	F		194					
Ambient temperature	°C		-15 to +40					
	F		5 to 104					
Lubrication	Synthetic transmission oil							
Paint	None							
Direction of rotation	See drawing							
Protection class	IP 65							
Moment of inertia <small>(relates to the drive)</small>	J_I	kgcm ²	2,27	2,03	1,94	1,84	1,81	1,86
		10 ⁻³ in.lb.s ²	2,01	1,80	1,72	1,63	1,60	1,64

^{a)} Idling torques decrease during operation

^{b)} Refers to center of the output shaft or flange

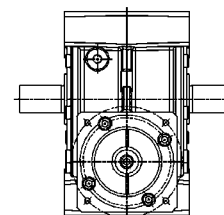
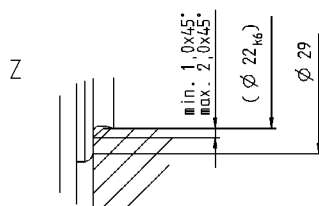
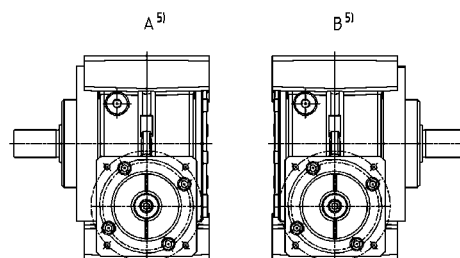
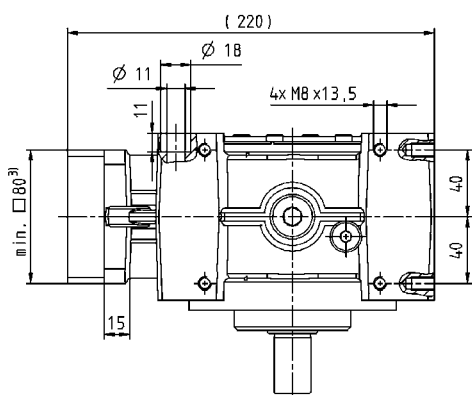
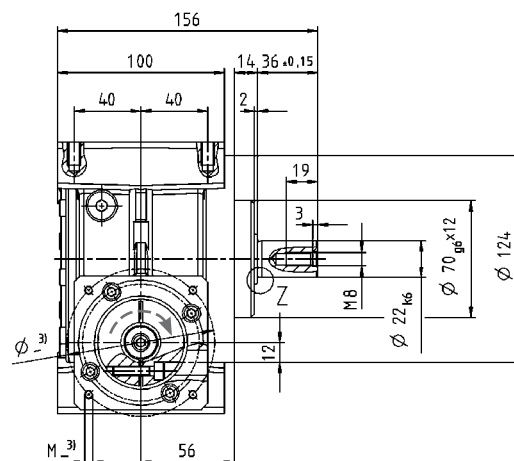
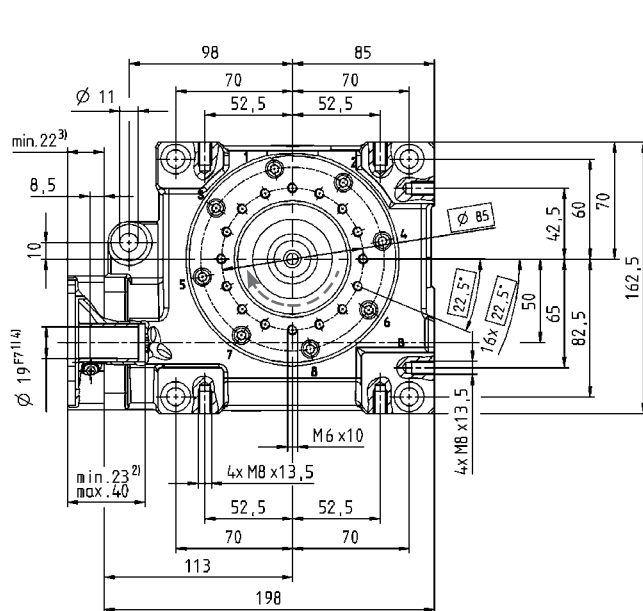

Optional dual-shaft output. Drawings available upon request.
Involute gearing is not possible.

Alternatives: Output shaft variants

Keywayed output shaft in mm
E = key as per DIN 6885, sheet 1, form A

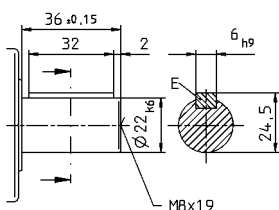

Involute gearing DIN 5480 in mm
X = W 22 x 1.25 x 30 x 16 x 6m

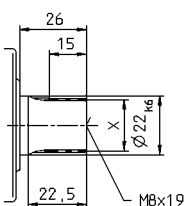

Non-tolerated dimensions ± 1 mm

- 1) Check motor shaft fit.
- 2) Min./Max. permissible motor shaft length.
Longer motor shafts are adaptable, please contact us.
- 3) The dimensions depend on the motor.
- 4) Smaller motor shaft diameter is compensated by a bushing with a minimum thickness of 1 mm.
- 5) Output side

⚠ Motor mounting according to operating manual



VDS+ 063 1-stage

			1-stage					
Ratio	<i>i</i>		4	7	10	16	28	40
$n_{IN}=500$ rpm	T_{2Max}	Nm	302	314	315	320	328	324
		in.lb	2673	2779	2788	2832	2903	2867
	T_{2Servo}	Nm	198	210	225	221	229	226
		in.lb	1752	1859	1991	1956	2027	2000
η	%		93	91	88	83	74	68
$n_{IN}=1000$ rpm	T_{2Max}	Nm	264	284	290	298	304	301
		in.lb	2336	2513	2567	2637	2690	2664
	T_{2Servo}	Nm	192	228	240	238	245	241
		in.lb	1699	2018	2124	2106	2168	2133
η	%		94	93	91	86	78	73
$n_{IN}=2000$ rpm	T_{2Max}	Nm	202	243	262	271	282	278
		in.lb	1788	2151	2319	2398	2496	2460
	T_{2Servo}	Nm	174	212	230	238	248	243
		in.lb	1540	1876	2036	2106	2195	2151
η	%		96	94	93	89	83	78
$n_{IN}=3000$ rpm	T_{2Max}	Nm	164	190	202	209	235	231
		in.lb	1451	1682	1788	1850	2080	2044
	T_{2Servo}	Nm	128	166	184	209	198	194
		in.lb	1133	1469	1628	1850	1752	1717
η	%		96	95	94	91	85	81
$n_{IN}=4000$ rpm	T_{2Max}	Nm	128	148	164	175	201	198
		in.lb	1133	1310	1451	1549	1779	1752
	T_{2Servo}	Nm	104	132	152	175	165	162
		in.lb	920	1168	1345	1549	1460	1434
η	%		97	96	94	92	86	83
Emergency stop torque	T_{2Not}	Nm	460	484	491	494	518	447
in.lb		4071	4283	4345	4372	4584	3956	
Max. input speed	n_{1Max}	rpm	4500					
Mean no load running torque ^{a)} <small>(With $n_{IN}=3000$ min⁻¹ and 20° C gear temperature)</small>	T_{012}	Nm	2,1	1,9	1,8	1,7	1,6	1,4
		in.lb	18,6	16,8	15,9	15,0	14,2	12,4
Max. torsional backlash	j_t	arcmin	≤3					
Torsional rigidity	C_{t21}	Nm/arcmin	28					
		in.lb/arcmin	248					
Max. axial force ^{b)}	F_{2AMax}	N	8250					
		lb _f	1856					
Max. radial force ^{b)}	F_{2RMMax}	N	6000					
		lb _f	1350					
Max. tilting moment	M_{2KMMax}	Nm	843					
		in.lb	7461					
Service life <small>(For calculation see "Information")</small>	L_h	h	> 20000					
Weight <small>(without motor attachment parts)</small>	m	kg	15					
		lb _m	33,2					
Operating noise <small>(with $n_{IN}=3000$ rpm no load)</small>	L_{PA}	dB(A)	≤ 64					
Max. permitted housing temperature	°C		+90					
	F		194					
Ambient temperature	°C		-15 to +40					
	F		5 to 104					
Lubrication	Synthetic transmission oil							
Paint	None							
Direction of rotation	See drawing							
Protection class	IP 65							
Moment of inertia <small>(relates to the drive)</small>	J_I	kgcm ²	6,72	5,79	5,54	5,44	5,41	5,35
		10 ⁻³ in.lb.s ²	5,95	5,12	4,90	4,82	4,78	4,74

^{a)} Idling torques decrease during operation

^{b)} Refers to center of the output shaft or flange

VDS+ 080 1-stage

			1-stage					
Ratio	<i>i</i>		4	7	10	16	28	40
$n_{IN}=500$ rpm	T_{2Max}	Nm	578	646	672	702	785	676
		in.lb	5115	5717	5947	6213	6947	5983
	T_{2Servo}	Nm	469	601	613	677	764	631
		in.lb	4151	5319	5425	5991	6761	5584
	η	%	94	92	89	86	77	70
$n_{IN}=1000$ rpm	T_{2Max}	Nm	514	602	588	656	698	613
		in.lb	4549	5328	5204	5806	6177	5425
	T_{2Servo}	Nm	491	574	561	625	665	584
		in.lb	4345	5080	4965	5531	5885	5168
	η	%	95	93	91	88	81	74
$n_{IN}=2000$ rpm	T_{2Max}	Nm	350	435	431	500	536	470
		in.lb	3098	3850	3814	4425	4744	4160
	T_{2Servo}	Nm	335	415	411	476	511	448
		in.lb	2965	3673	3637	4213	4522	3965
	η	%	96	95	93	89	84	79
$n_{IN}=3000$ rpm	T_{2Max}	Nm	259	336	334	400	433	380
		in.lb	2292	2974	2956	3540	3832	3363
	T_{2Servo}	Nm	247	320	319	381	413	362
		in.lb	2186	2832	2823	3372	3655	3204
	η	%	97	96	94	92	86	81
$n_{IN}=3500$ rpm	T_{2Max}	Nm	227	299	300	362	394	346
		in.lb	2009	2646	2655	3204	3487	3062
	T_{2Servo}	Nm	217	285	286	345	376	330
		in.lb	1920	2522	2531	3053	3328	2921
	η	%	97	96	94	92	87	82
Emergency stop torque	T_{2Not}	Nm	938	993	963	1005	1064	941
		in.lb						
Max. input speed	n_{1Max}	rpm	4000					
Mean no load running torque ^{a)} <small>(With $n_{IN}=3000$ min⁻¹ and 20° C gear temperature)</small>	T_{012}	Nm	3,6	3,5	3,4	3,2	3	2,8
		in.lb	31,9	31,0	30,1	28,3	26,6	24,8
Max. torsional backlash	j_t	arcmin	≤3					
Torsional rigidity	C_{t21}	Nm/arcmin	78					
		in.lb/arcmin	690					
Max. axial force ^{b)}	F_{2AMax}	N	13900					
		lb _f	3128					
Max. radial force ^{b)}	F_{2RMax}	N	9000					
		lb _f	2025					
Max. tilting moment	M_{2KMMax}	Nm	1544					
		in.lb	13664					
Service life <small>(For calculation see "Information")</small>	L_h	h	> 20000					
Weight <small>(without motor attachment parts)</small>	m	kg	32					
		lb _m	70,7					
Operating noise <small>(with $n_{IN}=3000$ rpm no load)</small>	L_{PA}	dB(A)	≤ 66					
Max. permitted housing temperature		°C	+90					
		F	194					
Ambient temperature		°C	-15 to +40					
		F	5 to 104					
Lubrication	Synthetic transmission oil							
Paint	None							
Direction of rotation	See drawing							
Protection class	IP 65							
Moment of inertia <small>(relates to the drive)</small>	J_I	kgcm ²	20,74	17,57	17,70	16,34	16,25	16,91
		10 ⁻³ in.lb.s ²	18,36	15,55	15,67	14,46	14,38	14,96

^{a)} Idling torques decrease during operation

^{b)} Refers to center of the output shaft or flange

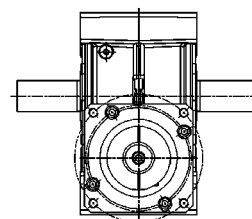
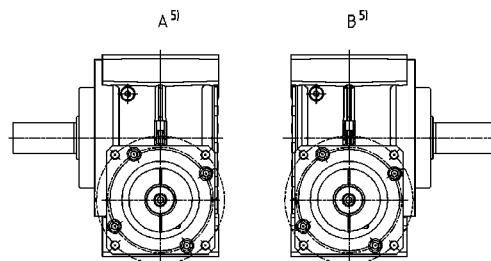
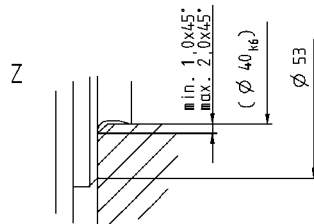
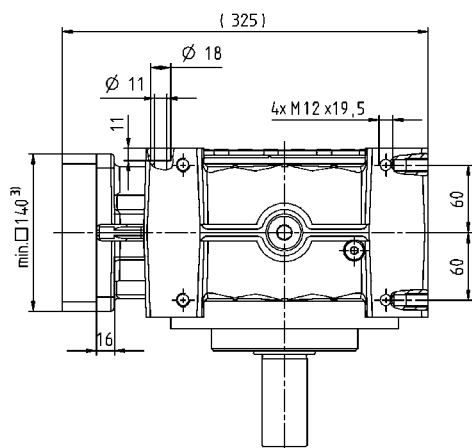
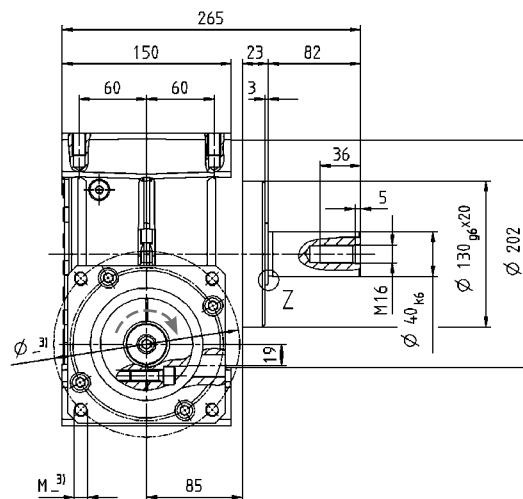
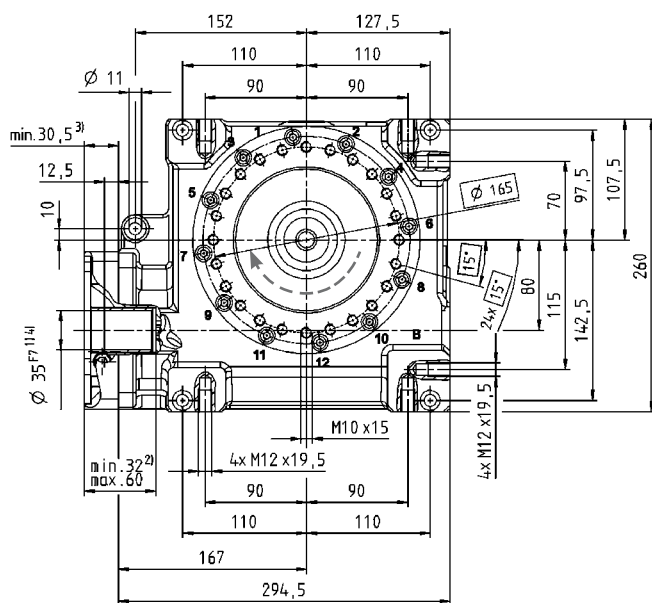

Optional dual-shaft output. Drawings available upon request. Involute gearing is not possible.

Alternatives: Output shaft variants

Keywayed output shaft in mm
E = key as per DIN 6885, sheet 1, form A

Involute gearing DIN 5480
X = W 40 x 2 x 30 x 18 x 6m

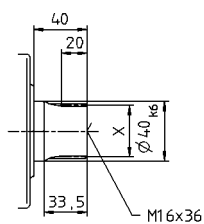
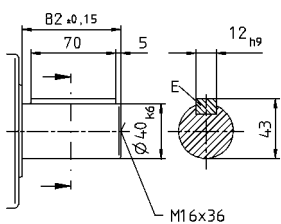

Non-tolerated dimensions ± 1 mm

- 1) Check motor shaft fit.
- 2) Min./Max. permissible motor shaft length.
Longer motor shafts are adaptable, please contact us.
- 3) The dimensions depend on the motor.
- 4) Smaller motor shaft diameter is compensated by a bushing with a minimum thickness of 1 mm.
- 5) Output side

⚠ Motor mounting according to operating manual



VDS+ 100 1-stage

			1-stage					
Ratio	<i>i</i>		4	7	10	16	28	40
$n_{IN}=500$ rpm	T_{2Max}	Nm	1184	1336	1377	1392	1505	1376
		in.lb	10478	11824	12186	12319	13319	12178
	T_{2Servo}	Nm	1155	1304	1343	1359	1469	1343
		in.lb	10222	11540	11886	12027	13001	11886
η	%	95	93	91	87	80	76	
$n_{IN}=1000$ rpm	T_{2Max}	Nm	905	1070	1122	1140	1251	1162
		in.lb	8009	9470	9930	10089	11071	10284
	T_{2Servo}	Nm	883	1044	1095	1113	1221	1134
		in.lb	7815	9239	9691	9850	10806	10036
η	%	95	94	92	88	82	79	
$n_{IN}=2000$ rpm	T_{2Max}	Nm	595	748	807	830	930	883
		in.lb	5266	6620	7142	7346	8231	7815
	T_{2Servo}	Nm	581	730	788	810	908	862
		in.lb	5142	6461	6974	7169	8036	7629
η	%	96	95	94	91	86	82	
$n_{IN}=3000$ rpm ^{c)}	T_{2Max}	Nm	430	564	621	644	735	709
		in.lb	3806	4991	5496	5699	6505	6275
	T_{2Servo}	Nm	420	551	606	629	718	692
		in.lb	3717	4876	5363	5567	6354	6124
η	%	97	96	95	92	87	84	
$n_{IN}=3500$ rpm	T_{2Max}	Nm	-	-	-	-	-	-
		in.lb	-	-	-	-	-	-
	η	%	-	-	-	-	-	-
Emergency stop torque	T_{2Not}	Nm	1819	1932	1940	1955	2073	1856
		in.lb	16098	17098	17169	17302	18346	16426
Max. input speed	n_{1Max}	rpm	3500					
Mean no load running torque ^{a)} <small>(With $n_{IN}=3000$ min⁻¹ and 20° C gear temperature)</small>	T_{012}	Nm	9,8	8,1	7,4	6,7	5,8	5
		in.lb	86,7	71,7	65,5	59,3	51,3	44,3
Max. torsional backlash	j_t	arcmin	≤3					
Torsional rigidity	C_{I21}	Nm/arcmin	153					
		in.lb/arcmin	1354					
Max. axial force ^{b)}	F_{2AMax}	N	19500					
		lb _f	4388					
Max. radial force ^{b)}	F_{2RMMax}	N	14000					
		lb _f	3150					
Max. tilting moment	M_{2KMMax}	Nm	3059					
		in.lb	27072					
Service life <small>(For calculation see "Information")</small>	L_h	h	> 20000					
Weight <small>(without motor attachment parts)</small>	m	kg	61					
		lb _m	134,8					
Operating noise <small>(with $n_{IN}=3000$ rpm no load)</small>	L_{PA}	dB(A)	≤ 70					
Max. permitted housing temperature		°C	+90					
		F	194					
Ambient temperature		°C	-15 to +40					
		F	5 to 104					
Lubrication			Synthetic transmission oil					
Paint			None					
Direction of rotation			See drawing					
Protection class			IP 65					
Moment of inertia <small>(relates to the drive)</small>	J_I	kgcm ²	65,59	56,20	54,30	55,17	52,71	53,04
		10 ⁻³ in.lb.s ²	58,05	49,73	48,06	48,83	46,65	46,94

^{a)} Idling torques decrease during operation

^{b)} Refers to center of the output shaft or flange

^{c)} Reduced by 20% in S1 operation

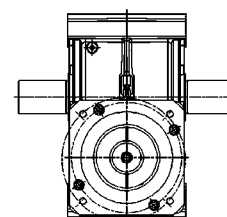
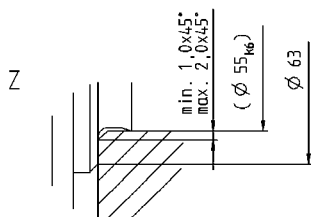
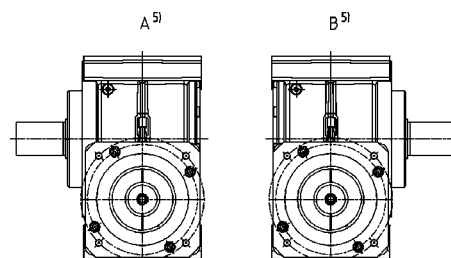
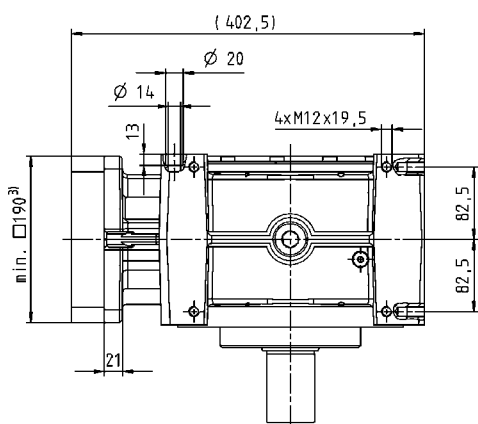
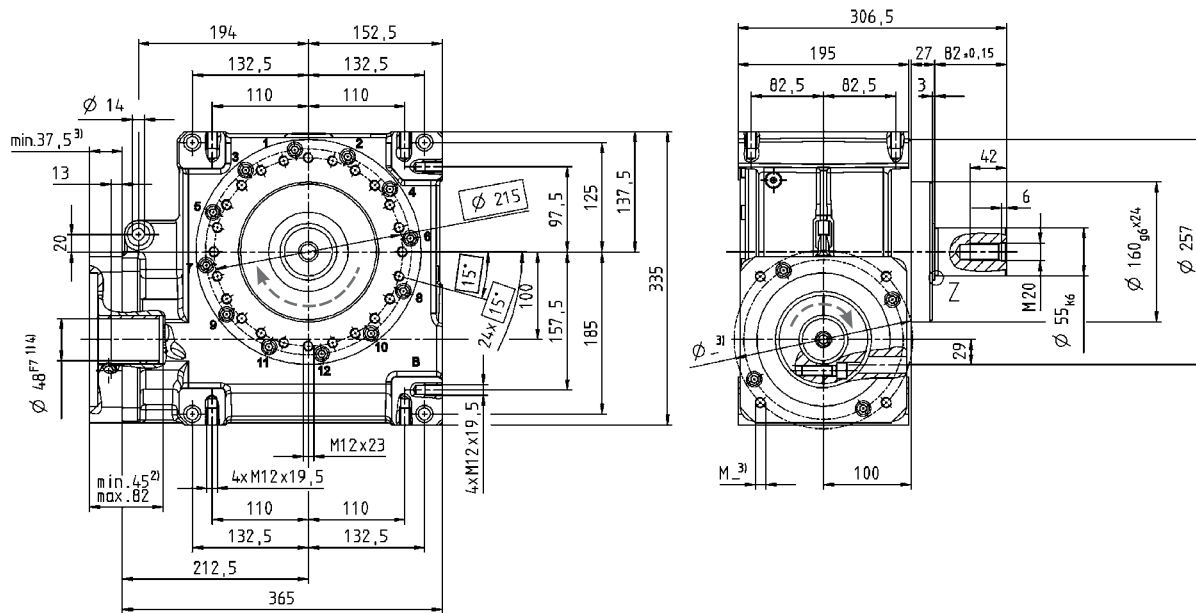

Optional dual-shaft output. Drawings available upon request.
Involute gearing is not possible.

Alternatives: Output shaft variants

Keywayed output shaft in mm
E = key as per DIN 6885, sheet 1, form A

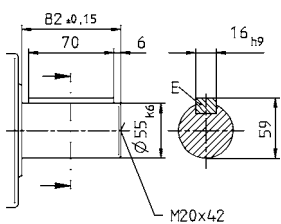

Involute gearing DIN 5480
X = W 55 x 2 x 30 x 26 x 6 m

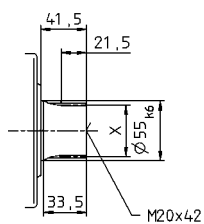

Non-tolerated dimensions ± 1 mm

- 1) Check motor shaft fit.
- 2) Min./Max. permissible motor shaft length.
Longer motor shafts are adaptable, please contact us.
- 3) The dimensions depend on the motor.
- 4) Smaller motor shaft diameter is compensated by a bushing with a minimum thickness of 1 mm.
- 5) Output side

⚠ Motor mounting according to operating manual



VDH+ 050 1-stage

			1-stage					
Ratio	<i>i</i>		4	7	10	16	28	40
$n_{IN}=500$ rpm	T_{2Max}	Nm	124	132	148	154	165	158
		in.lb	1097	1168	1310	1363	1460	1398
	T_{2Servo}	Nm	54	71	74	81	90	74
		in.lb	478	628	655	717	797	655
η	%		92	89	86	82	72	64
$n_{IN}=1000$ rpm	T_{2Max}	Nm	124	130	136	140	151	142
		in.lb	1097	1151	1204	1239	1336	1257
	T_{2Servo}	Nm	58	76	80	88	97	81
		in.lb	513	673	708	779	858	717
η	%		94	91	89	85	77	69
$n_{IN}=2000$ rpm	T_{2Max}	Nm	88	106	112	120	134	122
		in.lb	779	938	991	1062	1186	1080
	T_{2Servo}	Nm	60	78	82	89	99	83
		in.lb	531	690	726	788	876	735
η	%		95	93	91	88	75	75
$n_{IN}=3000$ rpm	T_{2Max}	Nm	72	86	95	106	112	108
		in.lb	637	761	841	938	991	956
	T_{2Servo}	Nm	59	77	81	88	97	81
		in.lb	522	681	717	779	858	717
η	%		96	94	93	90	83	78
$n_{IN}=4000$ rpm	T_{2Max}	Nm	62	77	83	92	102	95
		in.lb	549	681	735	814	903	841
	T_{2Servo}	Nm	58	76	79	87	96	80
		in.lb	513	673	699	770	850	708
η	%		96	95	93	91	85	80
Emergency stop torque	T_{2Not}	Nm	230	242	242	250	262	236
		in.lb	2036	2142	2142	2213	2319	2089
Max. input speed	n_{1Max}	rpm	6000					
Mean no load running torque ^{a)} <small>(With $n_{IN}=3000$ min⁻¹ and 20° C gear temperature)</small>	T_{012}	Nm	1,3	1,2	1,2	1,1	1	0,9
		in.lb	11,5	10,6	10,6	9,7	8,9	8,0
Max. torsional backlash	j_t	arcmin	≤3					
Torsional rigidity	C_{121}	Nm/arcmin	8					
		in.lb/arcmin	71					
Max. axial force ^{b)}	F_{2AMax}	N	5000					
		lb _f	1125					
Max. radial force ^{b)}	F_{2RMMax}	N	3800					
		lb _f	855					
Max. tilting moment	M_{2KMMax}	Nm	409					
		in.lb	3620					
Service life <small>(For calculation see "Information")</small>	L_h	h	> 20000					
Weight <small>(without motor attachment parts)</small>	m	kg	7,4					
		lb _m	16,4					
Operating noise <small>(with $n_{IN}=3000$ rpm no load)</small>	L_{PA}	dB(A)	≤ 62					
Max. permitted housing temperature	°C		+90					
	F		194					
Ambient temperature	°C		-15 to +40					
	F		5 to 104					
Lubrication	Synthetic transmission oil							
Paint	None							
Direction of rotation	See drawing							
Protection class	IP 65							
Moment of inertia <small>(relates to the drive)</small>	J_I	kgcm ²	2,31	2,02	1,93	1,84	1,81	1,86
		10 ⁻³ in.lb.s ²	2,04	1,79	1,71	1,63	1,60	1,64

^{a)} Idling torques decrease during operation

^{b)} Refers to center of the output shaft or flange

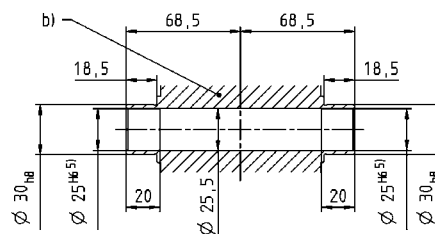
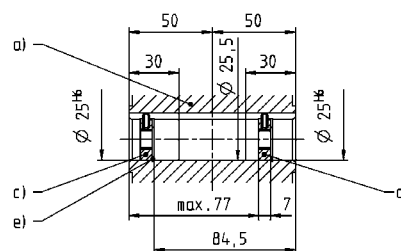
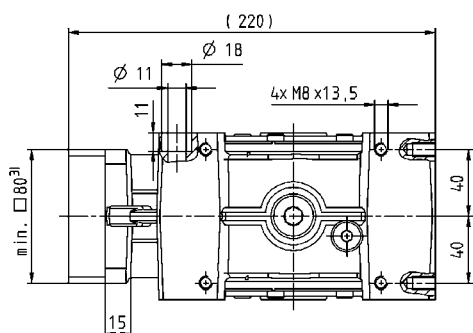
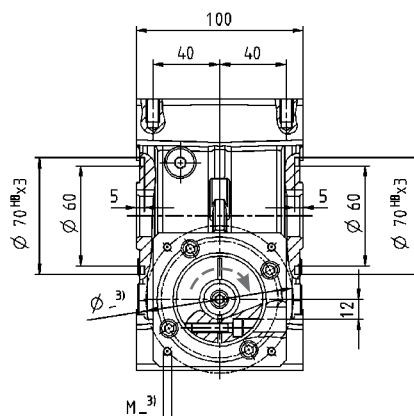
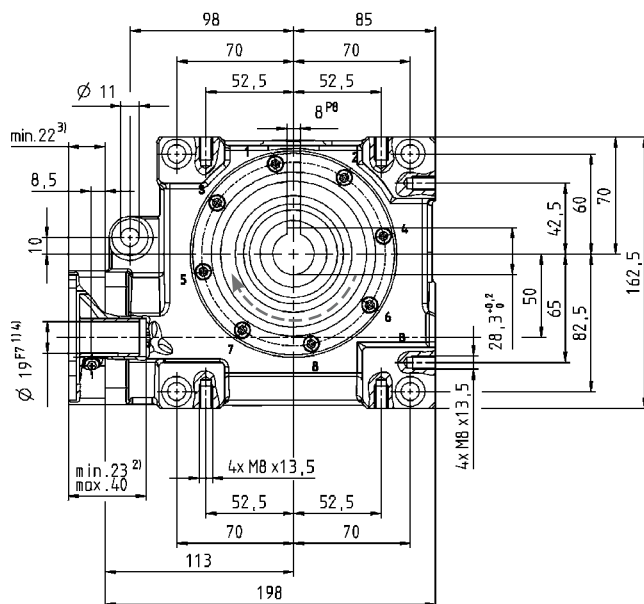

- a) Hollow shaft, keywayed
- b) Hollow shaft, smooth
- c) End disc for screw M10
- d) End disc as forcing washer for screw M12
- e) Locking ring – DIN 472

Non-tolerated dimensions ± 1 mm

- 1) Check motor shaft fit.
- 2) Min./Max. permissible motor shaft length.
Longer motor shafts are adaptable, please contact us.
- 3) The dimensions depend on the motor.
- 4) Smaller motor shaft diameter is compensated by a bushing with a minimum thickness of 1 mm.
- 5) Tolerance h6 for mounted shaft.

Motor mounting according to operating manual



VDH+ 063 1-stage

			1-stage					
Ratio	<i>i</i>		4	7	10	16	28	40
$n_{IN}=500$ rpm	T_{2Max}	Nm	302	314	315	320	328	324
		in.lb	2673	2779	2788	2832	2903	2867
	T_{2Servo}	Nm	198	210	225	221	229	226
		in.lb	1752	1859	1991	1956	2027	2000
η	%	93	91	88	83	74	68	
$n_{IN}=1000$ rpm	T_{2Max}	Nm	264	284	290	298	304	301
		in.lb	2336	2513	2567	2637	2690	2664
	T_{2Servo}	Nm	192	228	240	238	245	241
		in.lb	1699	2018	2124	2106	2168	2133
η	%	94	93	91	86	78	73	
$n_{IN}=2000$ rpm	T_{2Max}	Nm	202	243	262	271	282	278
		in.lb	1788	2151	2319	2398	2496	2460
	T_{2Servo}	Nm	174	212	230	238	248	243
		in.lb	1540	1876	2036	2106	2195	2151
η	%	96	94	93	89	83	78	
$n_{IN}=3000$ rpm	T_{2Max}	Nm	164	190	202	209	235	231
		in.lb	1451	1682	1788	1850	2080	2044
	T_{2Servo}	Nm	128	166	184	209	198	194
		in.lb	1133	1469	1628	1850	1752	1717
η	%	96	95	94	91	85	81	
$n_{IN}=4000$ rpm	T_{2Max}	Nm	128	148	164	175	201	198
		in.lb	1133	1310	1451	1549	1779	1752
	T_{2Servo}	Nm	104	132	152	175	165	162
		in.lb	920	1168	1345	1549	1460	1434
η	%	97	96	94	92	86	83	
Emergency stop torque	T_{2Not}	Nm	460	484	491	494	518	447
in.lb		4071	4283	4345	4372	4584	3956	
Max. input speed	n_{1Max}	rpm	4500					
Mean no load running torque ^{a)} <small>(With $n_{IN}=3000$ min⁻¹ and 20° C gear temperature)</small>	T_{012}	Nm	2,1	1,9	1,8	1,7	1,6	1,4
		in.lb	18,6	16,8	15,9	15,0	14,2	12,4
Max. torsional backlash	j_t	arcmin	≤3					
Torsional rigidity	C_{t21}	Nm/arcmin	28					
		in.lb/arcmin	248					
Max. axial force ^{b)}	F_{2AMax}	N	8250					
		lb _f	1856					
Max. radial force ^{b)}	F_{2RMMax}	N	6000					
		lb _f	1350					
Max. tilting moment	M_{2KMMax}	Nm	843					
		in.lb	7461					
Service life <small>(For calculation see "Information")</small>	L_h	h	> 20000					
Weight <small>(without motor attachment parts)</small>	m	kg	12					
		lb _m	26,5					
Operating noise <small>(with $n_{IN}=3000$ rpm no load)</small>	L_{PA}	dB(A)	≤ 64					
Max. permitted housing temperature		°C	+90					
		F	194					
Ambient temperature		°C	-15 to +40					
		F	5 to 104					
Lubrication	Synthetic transmission oil							
Paint	None							
Direction of rotation	See drawing							
Protection class	IP 65							
Moment of inertia <small>(relates to the drive)</small>	J_I	kgcm ²	6,68	5,77	5,53	5,44	5,40	5,35
		10 ⁻³ in.lb.s ²	5,91	5,11	4,89	4,81	4,78	4,74

^{a)} Idling torques decrease during operation

^{b)} Refers to center of the output shaft or flange

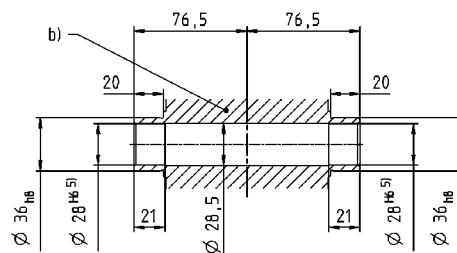
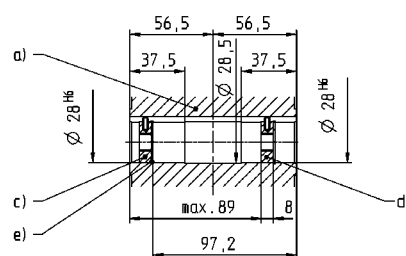
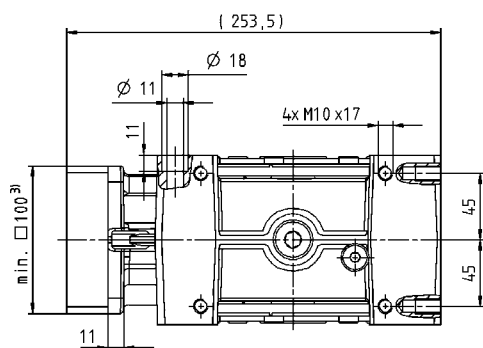
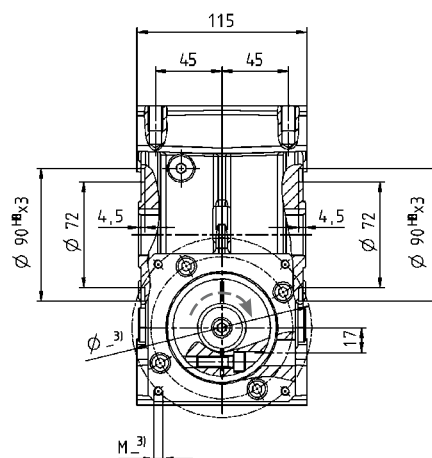
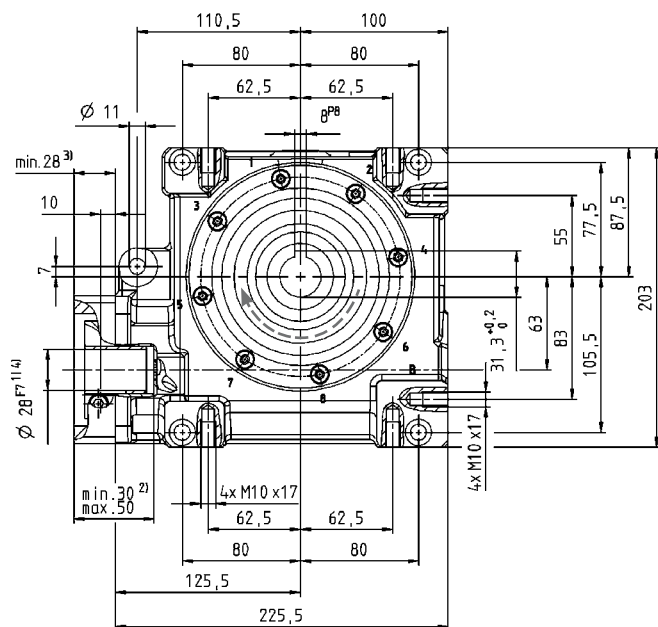

- a) Hollow shaft, keywayed
- b) Hollow shaft, smooth
- c) End disc for screw M10
- d) End disc as forcing washer for screw M12
- e) Locking ring – DIN 472

Non-tolerated dimensions ± 1 mm

- 1) Check motor shaft fit.
- 2) Min./Max. permissible motor shaft length.
Longer motor shafts are adaptable, please contact us.
- 3) The dimensions depend on the motor.
- 4) Smaller motor shaft diameter is compensated by a bushing with a minimum thickness of 1 mm.
- 5) Tolerance h6 for mounted shaft.

Motor mounting according to operating manual



VDH+ 080 1-stage

			1-stage					
Ratio	<i>i</i>		4	7	10	16	28	40
$n_{IN}=500$ rpm	T_{2Max}	Nm	578	646	672	702	785	676
		in.lb	5115	5717	5947	6213	6947	5983
	T_{2Servo}	Nm	469	601	613	677	764	631
		in.lb	4151	5319	5425	5991	6761	5584
η	%		94	92	89	86	77	70
$n_{IN}=1000$ rpm	T_{2Max}	Nm	514	602	588	656	698	613
		in.lb	4549	5328	5204	5806	6177	5425
	T_{2Servo}	Nm	491	574	561	625	665	584
		in.lb	4345	5080	4965	5531	5885	5168
η	%		95	93	91	88	81	74
$n_{IN}=2000$ rpm	T_{2Max}	Nm	350	435	431	500	536	470
		in.lb	3098	3850	3814	4425	4744	4160
	T_{2Servo}	Nm	335	415	411	476	511	448
		in.lb	2965	3673	3637	4213	4522	3965
η	%		96	95	93	89	84	79
$n_{IN}=3000$ rpm	T_{2Max}	Nm	259	336	334	400	433	380
		in.lb	2292	2974	2956	3540	3832	3363
	T_{2Servo}	Nm	247	320	319	381	413	362
		in.lb	2186	2832	2823	3372	3655	3204
η	%		97	96	94	92	86	81
$n_{IN}=3500$ rpm	T_{2Max}	Nm	227	299	300	362	394	346
		in.lb	2009	2646	2655	3204	3487	3062
	T_{2Servo}	Nm	217	285	286	345	376	330
		in.lb	1920	2522	2531	3053	3328	2921
η	%		97	96	94	92	87	82
Emergency stop torque	T_{2Not}	Nm	938	993	963	1005	1064	941
in.lb		8301	8788	8523	8894	9416	8328	
Max. input speed	n_{1Max}	rpm	4000					
Mean no load running torque ^{a)} <small>(With $n_{IN}=3000$ min⁻¹ and 20° C gear temperature)</small>	T_{012}	Nm	3,6	3,5	3,4	3,2	3	2,8
		in.lb	31,9	31,0	30,1	28,3	26,6	24,8
Max. torsional backlash	j_t	arcmin	≤3					
Torsional rigidity	C_{I21}	Nm/arcmin	78					
		in.lb/arcmin	690					
Max. axial force ^{b)}	F_{2AMax}	N	13900					
		lb _f	3128					
Max. radial force ^{b)}	F_{2RMMax}	N	9000					
		lb _f	2025					
Max. tilting moment	M_{2KMMax}	Nm	1544					
		in.lb	13664					
Service life <small>(For calculation see "Information")</small>	L_h	h	> 20000					
Weight <small>(without motor attachment parts)</small>	m	kg	26					
		lb _m	57,5					
Operating noise <small>(with $n_{IN}=3000$ rpm no load)</small>	L_{PA}	dB(A)	≤ 66					
Max. permitted housing temperature	°C		+90					
	F		194					
Ambient temperature	°C		-15 to +40					
	F		5 to 104					
Lubrication	Synthetic transmission oil							
Paint	None							
Direction of rotation	See drawing							
Protection class	IP 65							
Moment of inertia <small>(relates to the drive)</small>	J_I	kgcm ²	21,31	17,76	17,80	16,38	16,27	16,91
		10 ⁻³ in.lb.s ²	18,86	15,72	15,75	14,49	14,40	14,97

^{a)} Idling torques decrease during operation

^{b)} Refers to center of the output shaft or flange

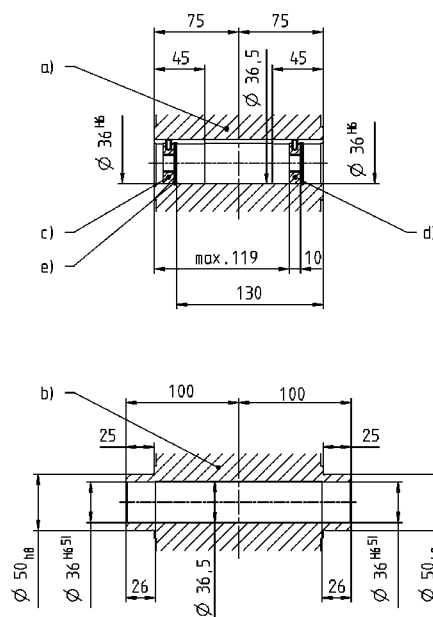
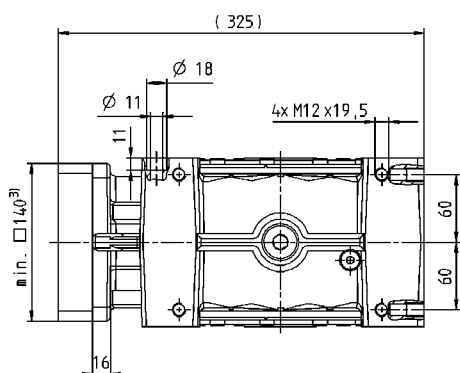
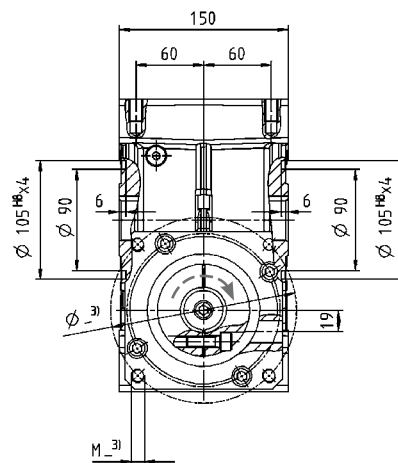
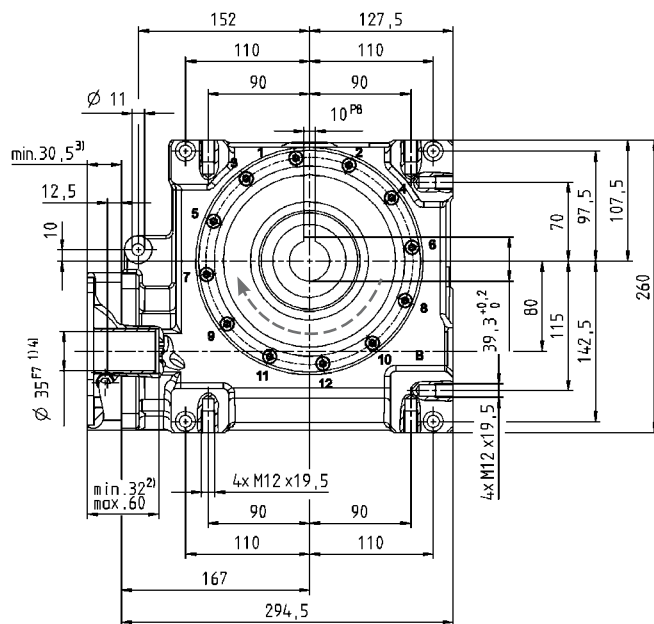

- a) Hollow shaft, keywayed
- b) Hollow shaft, smooth
- c) End disc for screw M12
- d) End disc as forcing washer for screw M16
- e) Locking ring – DIN 472

Non-tolerated dimensions ± 1 mm

- 1) Check motor shaft fit.
- 2) Min./Max. permissible motor shaft length.
Longer motor shafts are adaptable, please contact us.
- 3) The dimensions depend on the motor.
- 4) Smaller motor shaft diameter is compensated by a bushing with a minimum thickness of 1 mm.
- 5) Tolerance h6 for mounted shaft.

Motor mounting according to operating manual



VDH+ 100 1-stage

			1-stage					
Ratio	<i>i</i>		4	7	10	16	28	40
$n_{IN}=500$ rpm	T_{2Max}	Nm	1184	1336	1377	1392	1505	1376
		in.lb	10478	11824	12186	12319	13319	12178
	T_{2Servo}	Nm	1155	1304	1343	1359	1469	1343
		in.lb	10222	11540	11886	12027	13001	11886
η	%		95	93	91	87	80	76
$n_{IN}=1000$ rpm	T_{2Max}	Nm	905	1070	1122	1140	1251	1162
		in.lb	8009	9470	9930	10089	11071	10284
	T_{2Servo}	Nm	883	1044	1095	1113	1221	1134
		in.lb	7815	9239	9691	9850	10806	10036
η	%		95	94	92	88	82	79
$n_{IN}=2000$ rpm	T_{2Max}	Nm	595	748	807	830	930	883
		in.lb	5266	6620	7142	7346	8231	7815
	T_{2Servo}	Nm	581	730	788	810	908	862
		in.lb	5142	6461	6974	7169	8036	7629
η	%		96	95	94	91	86	82
$n_{IN}=3000$ rpm ^{c)}	T_{2Max}	Nm	430	564	621	644	735	709
		in.lb	3806	4991	5496	5699	6505	6275
	T_{2Servo}	Nm	420	551	606	629	718	692
		in.lb	3717	4876	5363	5567	6354	6124
η	%		97	96	95	92	87	84
$n_{IN}=3500$ rpm	T_{2Max}	Nm	-	-	-	-	-	-
		in.lb	-	-	-	-	-	-
	η	%		-	-	-	-	-
Emergency stop torque	T_{2Not}	Nm	1819	1932	1940	1955	2073	1856
		in.lb	16098	17098	17169	17302	18346	16426
Max. input speed	n_{1Max}	rpm	3500					
Mean no load running torque ^{a)} <small>(With $n_{IN}=3000$ min⁻¹ and 20° C gear temperature)</small>	T_{012}	Nm	9,8	8,1	7,4	6,7	5,8	5
		in.lb	86,7	71,7	65,5	59,3	51,3	44,3
Max. torsional backlash	j_t	arcmin	≤3					
Torsional rigidity	C_{I21}	Nm/arcmin	153					
		in.lb/arcmin	1354					
Max. axial force ^{b)}	F_{2AMax}	N	19500					
		lb _f	4388					
Max. radial force ^{b)}	F_{2RMax}	N	14000					
		lb _f	3150					
Max. tilting moment	M_{2KMax}	Nm	3059					
		in.lb	27072					
Service life <small>(For calculation see "Information")</small>	L_h	h	> 20000					
Weight <small>(without motor attachment parts)</small>	m	kg	50					
		lb _m	110,5					
Operating noise <small>(with $n_{IN}=3000$ rpm no load)</small>	L_{PA}	dB(A)	≤ 70					
Max. permitted housing temperature	°C		+90					
	F		194					
Ambient temperature	°C		-15 to +40					
	F		5 to 104					
Lubrication	Synthetic transmission oil							
Paint	None							
Direction of rotation	See drawing							
Protection class	IP 65							
Moment of inertia <small>(relates to the drive)</small>	J_I	kgcm ²	65,82	56,27	54,34	55,19	52,72	53,04
		10 ⁻³ in.lb.s ²	58,25	49,80	48,09	48,84	46,66	46,94

^{a)} Idling torques decrease during operation

^{b)} Refers to center of the output shaft or flange

^{c)} Reduced by 20% in S1 operation

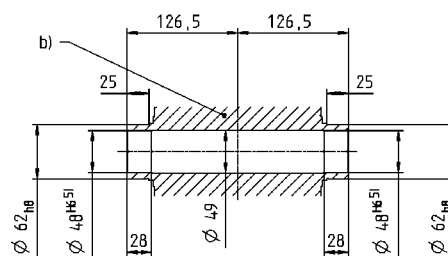
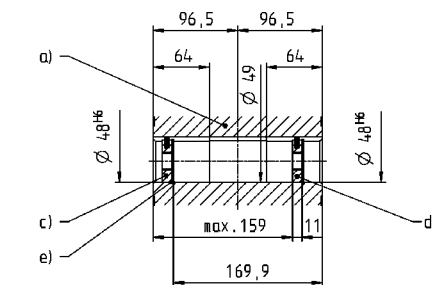
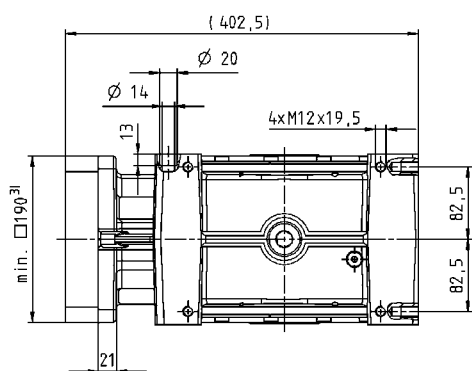
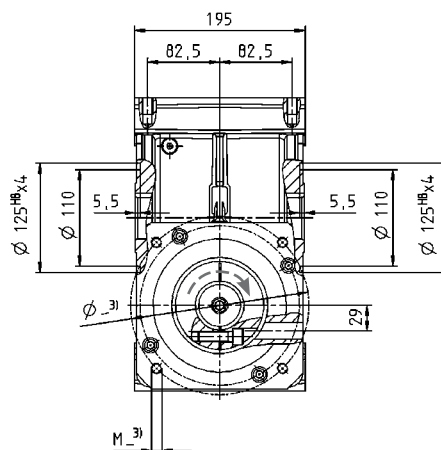
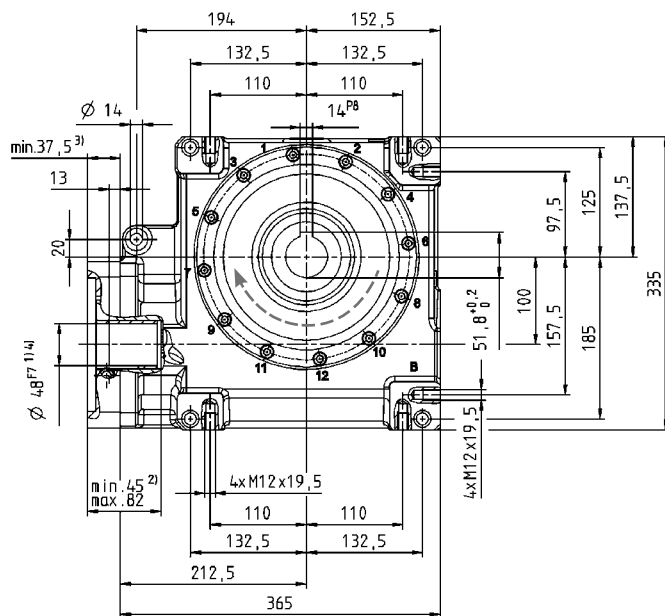

- a) Hollow shaft, keywayed
- b) Hollow shaft, smooth
- c) End disc for screw M16
- d) End disc as forcing washer for screw M20
- e) Locking ring – DIN 472

Non-tolerated dimensions ± 1 mm

- 1) Check motor shaft fit.
- 2) Min./Max. permissible motor shaft length.
Longer motor shafts are adaptable, please contact us.
- 3) The dimensions depend on the motor.
- 4) Smaller motor shaft diameter is compensated by a bushing with a minimum thickness of 1 mm.
- 5) Tolerance h6 for mounted shaft.

Motor mounting according to operating manual



VDS economy 050 1-stage

			1-stage					
Ratio	<i>i</i>		4	7	10	16	28	40
$n_{IN}=500$ rpm	T_{2Max}	Nm	–	102	111	118	128	116
		in.lb	–	903	982	1044	1133	1027
	T_{2Servo}	Nm	–	62	64	70	78	64
		in.lb	–	549	566	620	690	566
η	%	–	89	86	82	72	64	
$n_{IN}=1000$ rpm	T_{2Max}	Nm	–	103	108	114	124	112
		in.lb	–	912	956	1009	1097	991
	T_{2Servo}	Nm	–	66	70	76	84	70
		in.lb	–	584	620	673	743	620
η	%	–	91	89	85	77	69	
$n_{IN}=2000$ rpm	T_{2Max}	Nm	–	92	97	105	117	103
		in.lb	–	814	858	929	1035	912
	T_{2Servo}	Nm	–	68	71	77	86	72
		in.lb	–	602	628	681	761	637
η	%	–	93	91	88	75	75	
$n_{IN}=3000$ rpm	T_{2Max}	Nm	–	82	88	97	105	95
		in.lb	–	726	779	858	929	841
	T_{2Servo}	Nm	–	67	70	76	84	70
		in.lb	–	593	620	673	743	620
η	%	–	94	93	90	83	78	
$n_{IN}=4000$ rpm	T_{2Max}	Nm	–	77	81	90	99	88
		in.lb	–	681	717	797	876	779
	T_{2Servo}	Nm	–	64	69	75	83	69
		in.lb	–	566	611	664	735	611
η	%	–	95	93	91	85	80	
Emergency stop torque	T_{2Not}	Nm	–	242	242	250	262	236
		in.lb	–	2142	2142	2213	2319	2089
Max. input speed	n_{1Max}	rpm	6000					
Mean no load running torque ^{a)} (With $n_{IN}=3000$ min ⁻¹ and 20° C gear temperature)	T_{012}	Nm	–	1,2	1,2	1,1	1	0,9
		in.lb	–	10,6	10,6	9,7	8,9	8,0
Max. torsional backlash	j_t	arcmin	≤8					
Torsional rigidity	C_{I21}	Nm/arcmin	8					
		in.lb/arcmin	71					
Max. axial force ^{b)}	F_{2AMax}	N	5000					
		lb _f	1125					
Max. radial force ^{b)}	F_{2RMax}	N	3800					
		lb _f	855					
Max. tilting moment	M_{2KMMax}	Nm	409					
		in.lb	3620					
Service life (For calculation see "Information")	L_h	h	> 20000					
Weight (without motor attachment parts)	m	kg	7,7					
		lb _m	17,0					
Operating noise (with $n_{IN}=3000$ rpm no load)	L_{PA}	dB(A)	≤ 62					
Max. permitted housing temperature	°C		+90					
	F		194					
Ambient temperature	°C		-15 to +40					
	F		5 to 104					
Lubrication	Synthetic transmission oil							
Paint	None							
Direction of rotation	See drawing							
Protection class	IP 65							
Moment of inertia (relates to the drive)	J_I	kgcm ²	–	2,01	1,93	1,84	1,81	1,86
		10 ⁻³ in.lb.s ²	–	1,78	1,71	1,63	1,60	1,64

^{a)} Idling torques decrease during operation

^{b)} Refers to center of the output shaft or flange

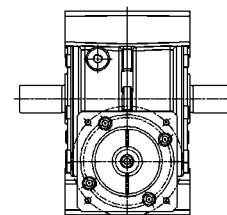
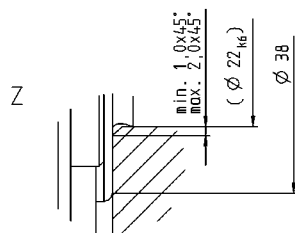
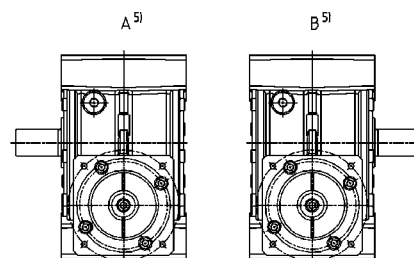
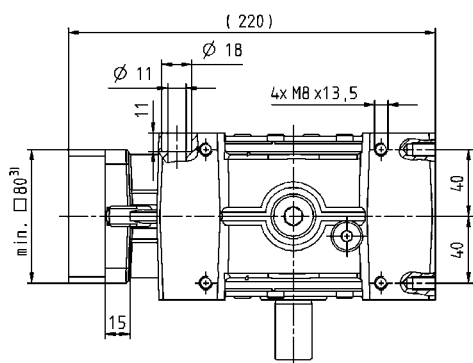
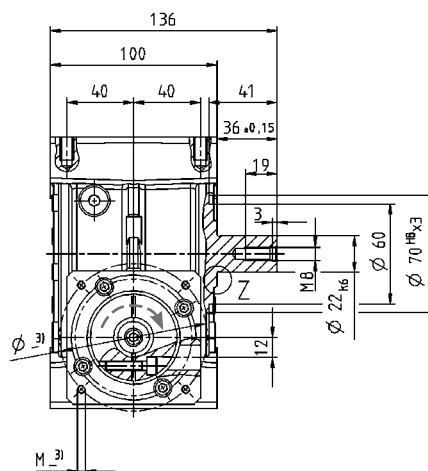
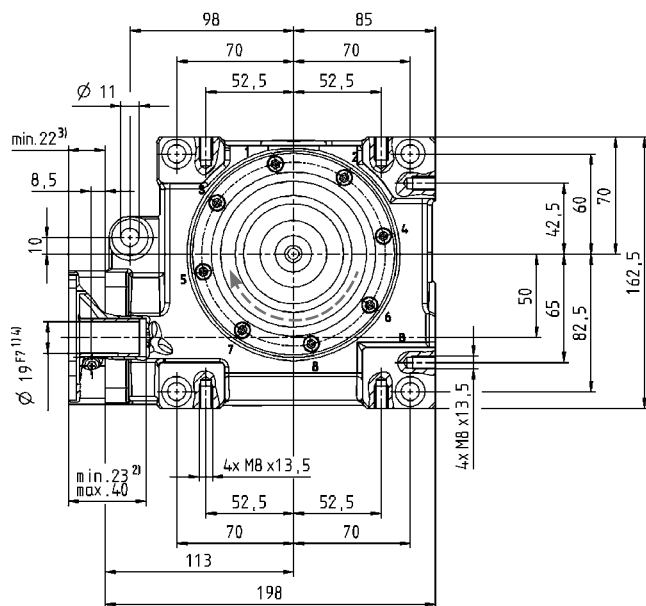

Optional dual-shaft output. Drawings available upon request.

Alternatives: Output shaft variants

Keywayed output shaft in mm
E = key as per DIN 6885, sheet 1, form A

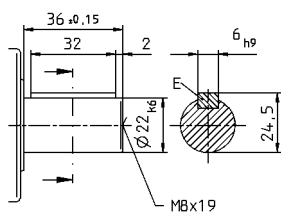

Non-tolerated dimensions ± 1 mm

- 1) Check motor shaft fit.
- 2) Min./Max. permissible motor shaft length.
Longer motor shafts are adaptable, please contact us.
- 3) The dimensions depend on the motor.
- 4) Smaller motor shaft diameter is compensated by a bushing with a minimum thickness of 1 mm.
- 5) Output side

⚠ Motor mounting according to operating manual



VDS economy 063 1-stage

			1-stage					
Ratio	<i>i</i>		4	7	10	16	28	40
$n_{IN}=500$ rpm	T_{2Max}	Nm	–	264	270	279	301	282
		in.lb	–	2336	2390	2469	2664	2496
	T_{2Servo}	Nm	–	183	195	198	215	201
		in.lb	–	1620	1726	1752	1903	1779
η	%	–	91	88	83	74	68	
$n_{IN}=1000$ rpm	T_{2Max}	Nm	–	256	265	276	299	280
		in.lb	–	2266	2345	2443	2646	2478
	T_{2Servo}	Nm	–	197	208	212	230	215
		in.lb	–	1743	1841	1876	2036	1903
η	%	–	93	91	86	78	73	
$n_{IN}=2000$ rpm	T_{2Max}	Nm	–	234	252	263	277	269
		in.lb	–	2071	2230	2328	2451	2381
	T_{2Servo}	Nm	–	188	203	212	224	217
		in.lb	–	1664	1797	1876	1982	1920
η	%	–	94	93	89	83	78	
$n_{IN}=3000$ rpm	T_{2Max}	Nm	–	183	198	209	230	224
		in.lb	–	1620	1752	1850	2036	1982
	T_{2Servo}	Nm	–	145	163	181	182	177
		in.lb	–	1283	1443	1602	1611	1566
η	%	–	95	94	91	85	81	
$n_{IN}=4000$ rpm	T_{2Max}	Nm	–	146	162	175	196	193
		in.lb	–	1292	1434	1549	1735	1708
	T_{2Servo}	Nm	–	114	134	152	152	149
		in.lb	–	1009	1186	1345	1345	1319
η	%	–	96	94	92	86	83	
Emergency stop torque	T_{2Not}	Nm	–	484	491	494	518	447
in.lb		–	4283	4345	4372	4584	3956	
Max. input speed	n_{1Max}	rpm	4500					
Mean no load running torque ^{a)} <small>(With $n_1=3000$ min⁻¹ and 20° C gear temperature)</small>	T_{012}	Nm	–	1,9	1,8	1,7	1,6	1,4
		in.lb	–	16,8	15,9	15,0	14,2	12,4
Max. torsional backlash	j_t	arcmin	≤8					
Torsional rigidity	C_{t21}	Nm/arcmin	28					
		in.lb/arcmin	248					
Max. axial force ^{b)}	F_{2AMax}	N	8250					
		lb _f	1856					
Max. radial force ^{b)}	F_{2RMMax}	N	6000					
		lb _f	1350					
Max. tilting moment	M_{2KMMax}	Nm	843					
		in.lb	7461					
Service life <small>(For calculation see "Information")</small>	L_h	h	> 20000					
Weight <small>(without motor attachment parts)</small>	m	kg	12,5					
		lb _m	27,6					
Operating noise <small>(with $n_1=3000$ rpm no load)</small>	L_{PA}	dB(A)	≤ 64					
Max. permitted housing temperature	°C		+90					
	F		194					
Ambient temperature	°C		-15 to +40					
	F		5 to 104					
Lubrication	Synthetic transmission oil							
Paint	None							
Direction of rotation	See drawing							
Protection class	IP 65							
Moment of inertia <small>(relates to the drive)</small>	J_I	kgcm ²	–	5,78	5,53	5,44	5,40	5,35
		10 ⁻³ in.lb.s ²	–	5,12	4,90	4,82	4,78	4,74

^{a)} Idling torques decrease during operation

^{b)} Refers to center of the output shaft or flange

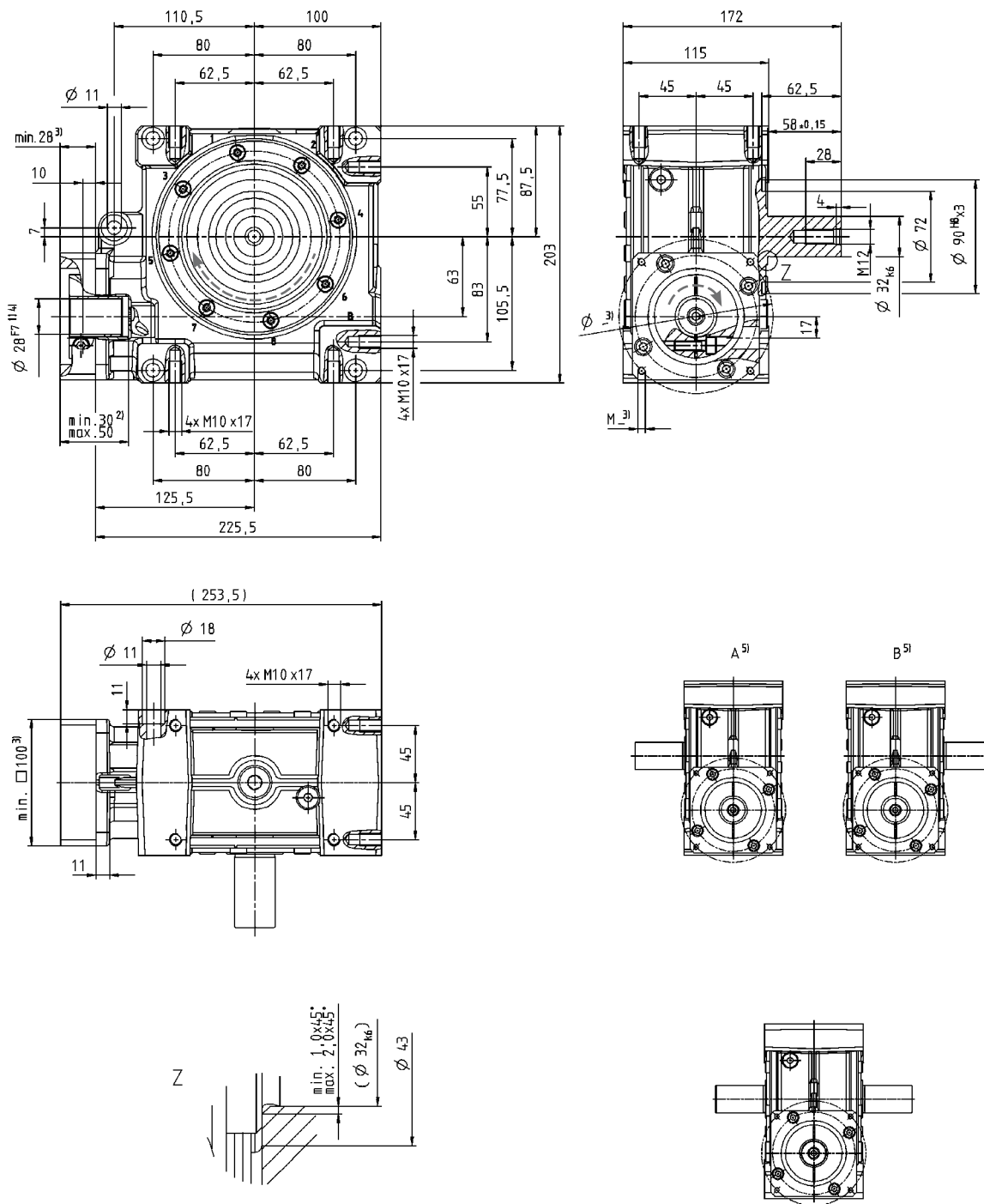

Optional dual-shaft output. Drawings available upon request.

Alternatives: Output shaft variants

Keywayed output shaft in mm
E = key as per DIN 6885, sheet 1, form A

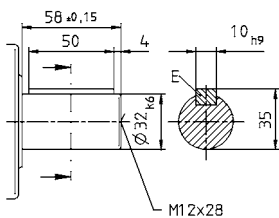

Non-tolerated dimensions ± 1 mm

- 1) Check motor shaft fit.
- 2) Min./Max. permissible motor shaft length.
Longer motor shafts are adaptable, please contact us.
- 3) The dimensions depend on the motor.
- 4) Smaller motor shaft diameter is compensated by a bushing with a minimum thickness of 1 mm.
- 5) Output side

Motor mounting according to operating manual



VDH economy 050 1-stage

			1-stage					
Ratio	<i>i</i>		4	7	10	16	28	40
$n_{IN}=500$ rpm	T_{2Max}	Nm	–	102	111	118	128	116
		in.lb	–	903	982	1044	1133	1027
	T_{2Servo}	Nm	–	62	64	70	78	64
		in.lb	–	549	566	620	690	566
	η	%	–	89	86	82	72	64
$n_{IN}=1000$ rpm	T_{2Max}	Nm	–	103	108	114	124	112
		in.lb	–	912	956	1009	1097	991
	T_{2Servo}	Nm	–	66	70	76	84	70
		in.lb	–	584	620	673	743	620
	η	%	–	91	89	85	77	69
$n_{IN}=2000$ rpm	T_{2Max}	Nm	–	92	97	105	117	103
		in.lb	–	814	858	929	1035	912
	T_{2Servo}	Nm	–	68	71	77	86	72
		in.lb	–	602	628	681	761	637
	η	%	–	93	91	88	75	75
$n_{IN}=3000$ rpm	T_{2Max}	Nm	–	82	88	97	105	95
		in.lb	–	726	779	858	929	841
	T_{2Servo}	Nm	–	67	70	76	84	70
		in.lb	–	593	620	673	743	620
	η	%	–	94	93	90	83	78
$n_{IN}=4000$ rpm	T_{2Max}	Nm	–	77	81	90	99	88
		in.lb	–	681	717	797	876	779
	T_{2Servo}	Nm	–	64	69	75	83	69
		in.lb	–	566	611	664	735	611
	η	%	–	95	93	91	85	80
Emergency stop torque	T_{2Not}	Nm	–	242	242	250	262	236
in.lb		–	2142	2142	2213	2319	2089	
Max. input speed	n_{1Max}	rpm	6000					
Mean no load running torque ^{a)} (With $n_1=3000$ min ⁻¹ and 20° C gear temperature)	T_{012}	Nm	–	1,2	1,2	1,1	1	0,9
		in.lb	–	10,6	10,6	9,7	8,9	8,0
Max. torsional backlash	j_t	arcmin	≤8					
Torsional rigidity	C_{I21}	Nm/arcmin	8					
		in.lb/arcmin	71					
Max. axial force ^{b)}	F_{2AMax}	N	5000					
		lb _f	1125					
Max. radial force ^{b)}	F_{2RMax}	N	3800					
		lb _f	855					
Max. tilting moment	M_{2KMMax}	Nm	409					
		in.lb	3620					
Service life (For calculation see "Information")	L_h	h	> 20000					
Weight (without motor attachment parts)	m	kg	7,4					
		lb _m	16,4					
Operating noise (with $n_1=3000$ rpm no load)	L_{PA}	dB(A)	≤ 62					
Max. permitted housing temperature	°C		+90					
	F		194					
Ambient temperature	°C		-15 to +40					
	F		5 to 104					
Lubrication	Synthetic transmission oil							
Paint	None							
Direction of rotation	See drawing							
Protection class	IP 65							
Moment of inertia (relates to the drive)	J_I	kgcm ²	–	2,02	1,93	1,84	1,81	1,86
		10 ⁻³ in.lb.s ²	–	1,79	1,71	1,63	1,60	1,64

^{a)} Idling torques decrease during operation

^{b)} Refers to center of the output shaft or flange

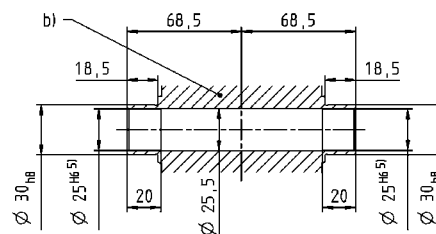
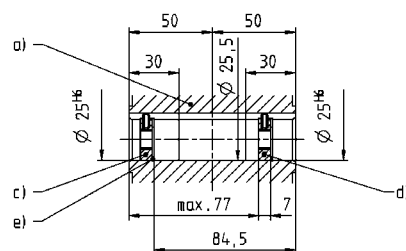
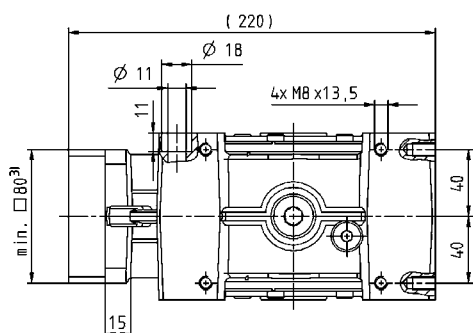
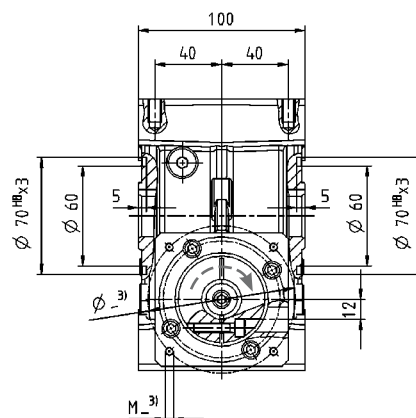
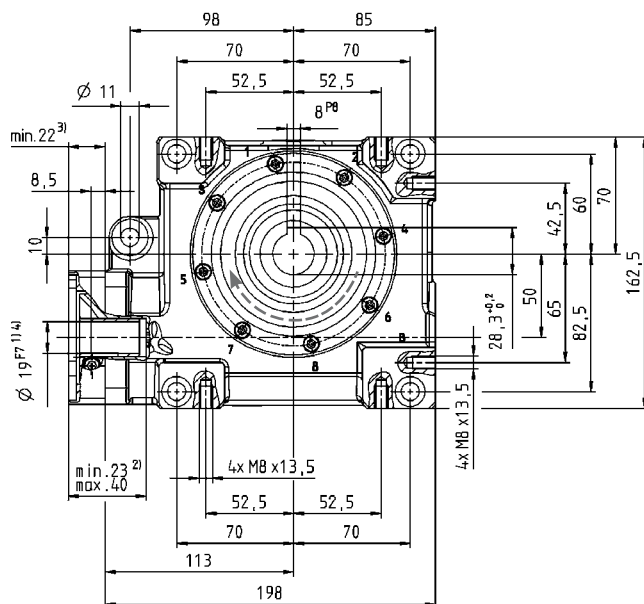

- a) Hollow shaft, keywayed
- b) Hollow shaft, smooth
- c) End disc for screw M10 (on request)
- d) End disc as forcing washer for screw M12 (on request)
- e) Locking ring – DIN 472 (on request)

Non-tolerated dimensions ± 1 mm

- 1) Check motor shaft fit.
- 2) Min./Max. permissible motor shaft length.
Longer motor shafts are adaptable, please contact us.
- 3) The dimensions depend on the motor.
- 4) Smaller motor shaft diameter is compensated by a bushing with a minimum thickness of 1 mm.
- 5) Tolerance h6 for mounted shaft.

Motor mounting according to operating manual



VDH economy 063 1-stage

			1-stage					
Ratio	<i>i</i>		4	7	10	16	28	40
$n_{IN}=500$ rpm	T_{2Max}	Nm	–	264	270	279	301	282
		in.lb	–	2336	2390	2469	2664	2496
	T_{2Servo}	Nm	–	183	195	198	215	201
		in.lb	–	1620	1726	1752	1903	1779
η	%	–	91	88	83	74	68	
$n_{IN}=1000$ rpm	T_{2Max}	Nm	–	256	265	276	299	280
		in.lb	–	2266	2345	2443	2646	2478
	T_{2Servo}	Nm	–	197	208	212	230	215
		in.lb	–	1743	1841	1876	2036	1903
η	%	–	93	91	86	78	73	
$n_{IN}=2000$ rpm	T_{2Max}	Nm	–	234	252	263	277	269
		in.lb	–	2071	2230	2328	2451	2381
	T_{2Servo}	Nm	–	188	203	212	224	217
		in.lb	–	1664	1797	1876	1982	1920
η	%	–	94	93	89	83	78	
$n_{IN}=3000$ rpm	T_{2Max}	Nm	–	183	198	209	230	224
		in.lb	–	1620	1752	1850	2036	1982
	T_{2Servo}	Nm	–	145	163	181	182	177
		in.lb	–	1283	1443	1602	1611	1566
η	%	–	95	94	91	85	81	
$n_{IN}=4000$ rpm	T_{2Max}	Nm	–	146	162	175	196	193
		in.lb	–	1292	1434	1549	1735	1708
	T_{2Servo}	Nm	–	114	134	152	152	149
		in.lb	–	1009	1186	1345	1345	1319
η	%	–	96	94	92	86	83	
Emergency stop torque	T_{2Not}	Nm	–	484	491	494	518	447
in.lb		–	4283	4345	4372	4584	3956	
Max. input speed	n_{1Max}	rpm	4500					
Mean no load running torque ^{a)} <small>(With $n_1=3000$ min⁻¹ and 20° C gear temperature)</small>	T_{012}	Nm	–	1,9	1,8	1,7	1,6	1,4
		in.lb	–	16,8	15,9	15,0	14,2	12,4
Max. torsional backlash	j_t	arcmin	≤8					
Torsional rigidity	C_{t21}	Nm/arcmin	28					
		in.lb/arcmin	248					
Max. axial force ^{b)}	F_{2AMax}	N	8250					
		lb _f	1856					
Max. radial force ^{b)}	F_{2RMMax}	N	6000					
		lb _f	1350					
Max. tilting moment	M_{2KMMax}	Nm	843					
		in.lb	7461					
Service life <small>(For calculation see "Information")</small>	L_h	h	> 20000					
Weight <small>(without motor attachment parts)</small>	m	kg	12					
		lb _m	26,5					
Operating noise <small>(with $n_1=3000$ rpm no load)</small>	L_{PA}	dB(A)	≤ 64					
Max. permitted housing temperature		°C	+90					
		F	194					
Ambient temperature		°C	-15 to +40					
		F	5 to 104					
Lubrication	Synthetic transmission oil							
Paint	None							
Direction of rotation	See drawing							
Protection class	IP 65							
Moment of inertia <small>(relates to the drive)</small>	J_I	kgcm ²	–	5,77	5,53	5,44	5,40	5,35
		10 ⁻³ in.lb.s ²	–	5,11	4,89	4,81	4,78	4,74

^{a)} Idling torques decrease during operation

^{b)} Refers to center of the output shaft or flange

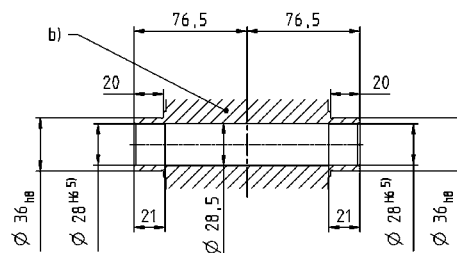
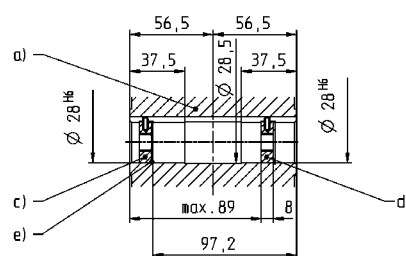
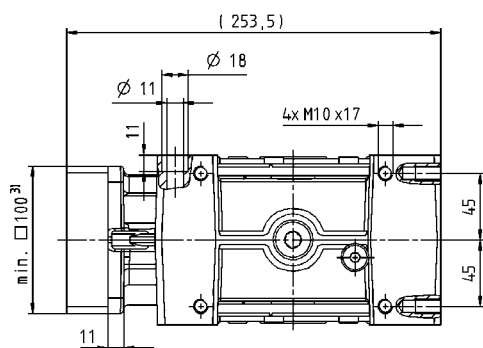
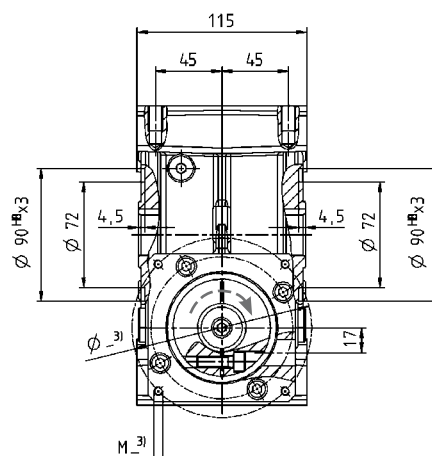
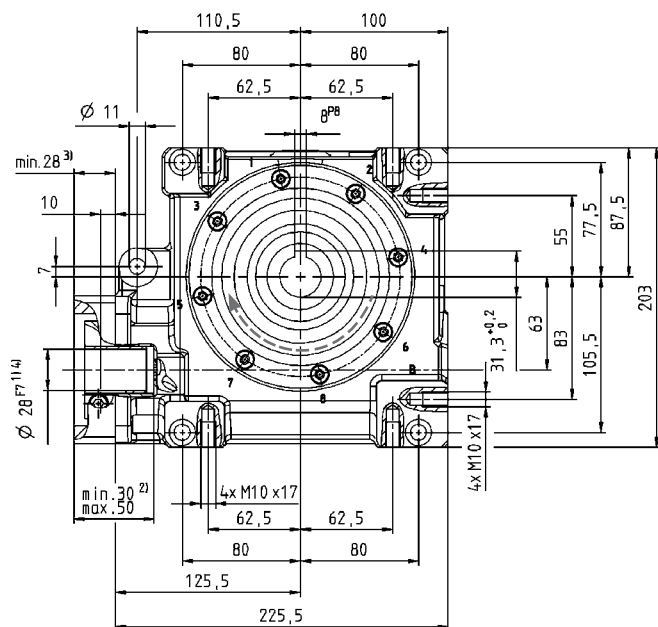

- a) Hollow shaft, keywayed
- b) Hollow shaft, smooth
- c) End disc for screw M10 (on request)
- d) End disc as forcing washer for screw M12 (on request)
- e) Locking ring – DIN 472 (on request)

Non-tolerated dimensions ± 1 mm

- 1) Check motor shaft fit.
- 2) Min./Max. permissible motor shaft length.
Longer motor shafts are adaptable, please contact us.
- 3) The dimensions depend on the motor.
- 4) Smaller motor shaft diameter is compensated by a bushing with a minimum thickness of 1 mm.
- 5) Tolerance h6 for mounted shaft.

Motor mounting according to operating manual



Putting you one step ahead of the rest: Mechanical systems by WITTENSTEIN alpha

More precise, more individual, more compact – mechanical systems by WITTENSTEIN alpha and numerous special applications have opened up a whole new range of possibilities. Maximizing performance. Achieving more. Progressing faster. Solution-oriented, individualized systems, compatible with all WITTENSTEIN alpha gearheads: alpha Rack & Pinion System, alpha IQ and couplings by WITTENSTEIN alpha. Optimizing your company's plans for the future.



Mechanical systems

alpha Rack & Pinion System

Recognizing individuality. Benefiting from experience. Achieving harmony.

We are more than familiar with the combination of gearhead, motor and pinion. We are adding extra depth to our experience by developing mechanical systems with an outstanding capacity for integration. For maximum machine efficiency. Outstanding dynamics. Compact dimensions. Individual solutions that help bring you one step closer to achieving your ambitious goals.

alpha Rack & Pinion System



alpha IQ



Couplings



alpha IQ

Achieving compatibility. Utilizing intelligence. Increasing efficiency.

A gearhead and measuring instrument in one system, fully compatible with all WITTENSTEIN alpha gearheads, continuous realtime data acquisition during operation – alpha IQ, the intelligent planetary gearhead. For continuous data acquisition and drive component monitoring, for increasing productivity and process stability. Innovative engineers are not the only ones getting excited about this system. Operating companies will have something to write home about too.

Couplings

Redefining movement. Refining transmission processes. Crossing boundaries.

For WITTENSTEIN alpha couplings, freedom of innovation means: A maximum acceleration torque of 10,000 Nm, disengagement within 1–3 ms and a belt tension of 100 to 12,000 N combined with absolute torsional rigidity, simple installation, a self-adjustment function and no maintenance. High-tech components for the harmonious transmission of power and movement – in all applications where improved performance means forward progress.



alpha Rack & Pinion System – a perfect combination of gearhead, pinion and rack – ranging from low-cost to high-end systems

alpha Rack & Pinion Systems

Details



www.rack-pinion.com

alpha Rack & Pinion System –

a **perfect symbiosis** of **state-of-the-art technology** and **many years of experience**.

alpha is the next generation of rack and pinion systems. Our specialist knowledge extends from the separate coupling of gearhead, motor, pinion and rack to complete system solutions.

For further informations please visit our website: www.rack-pinion.com

The alternative – not only for long distances

Rack and pinion combinations do not only excel in applications involving long, precise movement paths.

The WITTENSTEIN alpha technology achieves an excellent degree of precision using an **electronic tensioning** system. The **high-precision manufacture** of individual components is an essential aspect here because manufacturers and users must be able to rely on the installed drives to achieve the level of accuracy required.

We offer the **highest levels of** precision, dynamics and rigidity as well as an extended service life that more than satisfy the demanding requirements of machine and system manufacturers.

The result of our efforts is maximum performance across the board.

WITTENSTEIN alpha has managed to move the old established system of rack and pinion **back into the fast lane**.

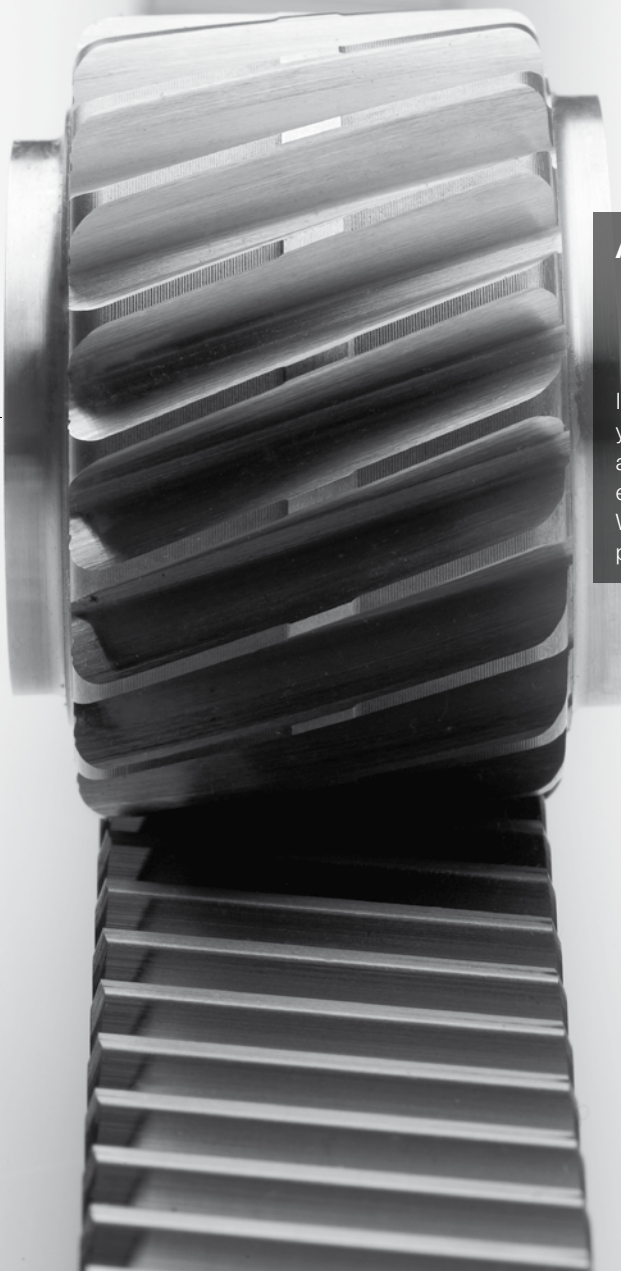

Always there for you.

If you are striving to achieve your objectives quickly and implement solutions efficiently and individually, then WITTENSTEIN alpha is the perfect partner for you.

Make a decision in favor of world-class technology that will give your customers a leading edge and help further consolidate your partnership together.



The **systems** and **applications**

Machine precision *

The right gearhead, rack and pinion **for every application** – from low-cost to high-end solutions. The positioning accuracy required in the application, the existing measuring system and the machine design essentially determine the configuration of linear systems and system combinations.

A real powerhouse with a **compact design**. Constant **rigidity** and outstanding **dynamics**. Easy to operate, quickly becomes indispensable. **Customized** to suit your specific application areas.

1 μm	Master/Slave: TP System output with Premium Class⁺ pinion and Premium Class rack
5 μm	TP System output with Premium Class⁺ pinion and Premium Class rack
20 μm	TP output with Premium Class RTP pinion and Premium/Smart Class rack
50 μm	SP System output with Premium Class⁺ pinion and Premium/Smart Class rack
100 μm	SP involute output with Standard Class RSP pinion and Value/Smart Class rack
200 μm	Key output with Value Class pinion and Value/Smart Class rack
>300 μm	

* depending on other components.

Competent consultation

Staff at our **Technical Office** will be glad to answer any questions you may have about alpha Rack & Pinion Systems and your specific configurations. Give us a call!



HSC (High Speed Cutting) portal milling machines
Source: F. Zimmermann GmbH



Profile machining centers
Source: Handtmann A-Punkt Automation GmbH



Laser machines
Source: TRUMPF Werkzeugmaschinen GmbH + Co. KG

Precision System

Eroding machines · Grinding machines · HSC portal milling machines · Turning machines · Machining centers · Boring machines · Laser machines · Punching machines

Measuring System

DIRECT

INDIRECT

Precision+ System/ Precision System

for demanding requirements with regard to dynamics and accuracy in high-end applications.

Smart System

for positioning options with **more design freedom** in flexible applications.

Economy+ System/ Economy System

for standard linear applications in mid-range/low-cost applications.

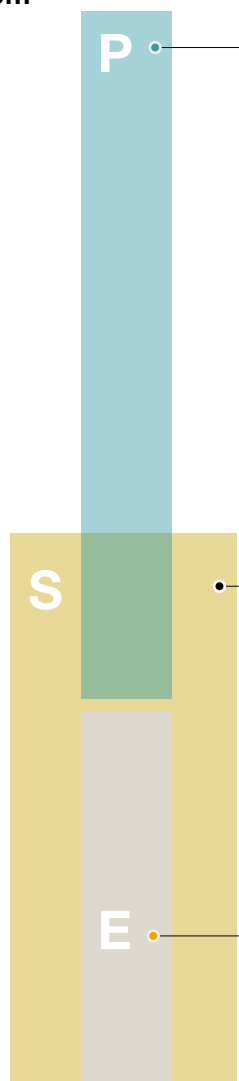
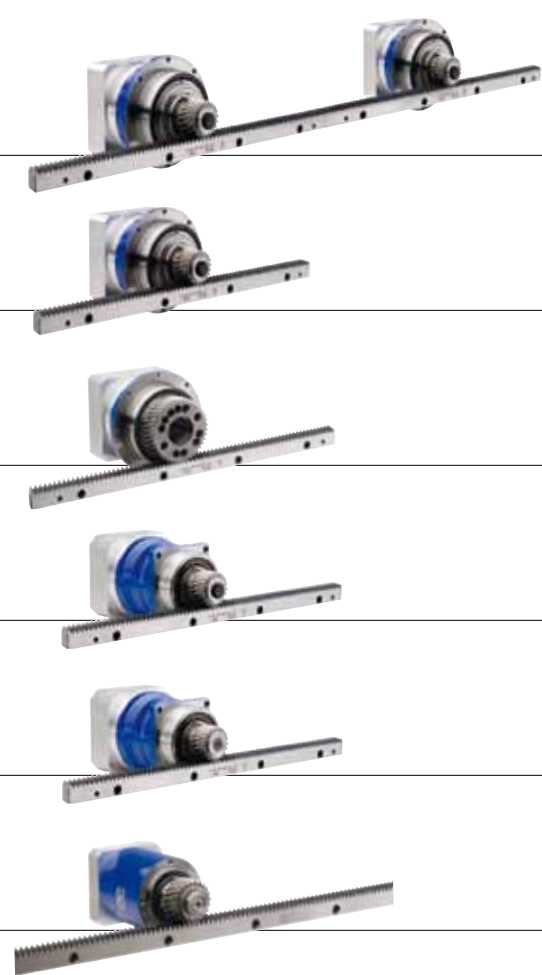

Wood, plastic/composite machining centers
Source: MAKA – Max Mayer Maschinenbau GmbH © MAKA



Gas cutting machines
Source: LIND GmbH Industrial Equipment



Robot arms in automation engineering
Source: MOTOMAN Robotics Europe AB

Smart System

Economy System

Water jet cutting machines · CNC wood/plastic processing machines · Gas cutting machines · Pipe bending machines · Foam cutting machines · Automation engineering

Rack & Pinion



Master/Slave: TP System output with Premium Class pinion and Premium Class rack



alpha Rack & Pinion System

alpha Rack & Pinion System – **the benefits for you**

Dynamic

- Maximum movement speed and acceleration with low moments of inertia.
- Extremely good control characteristics due to constant linear rigidity along the entire movement path.

Precise

- New drive solutions with unique true running accuracy.
- Maximum positioning accuracy due to precision alignment of components.

Efficient

- Effortless operation.
- Minimal mounting space and high power density.
- Enormous savings potential due to high level of energy efficiency.

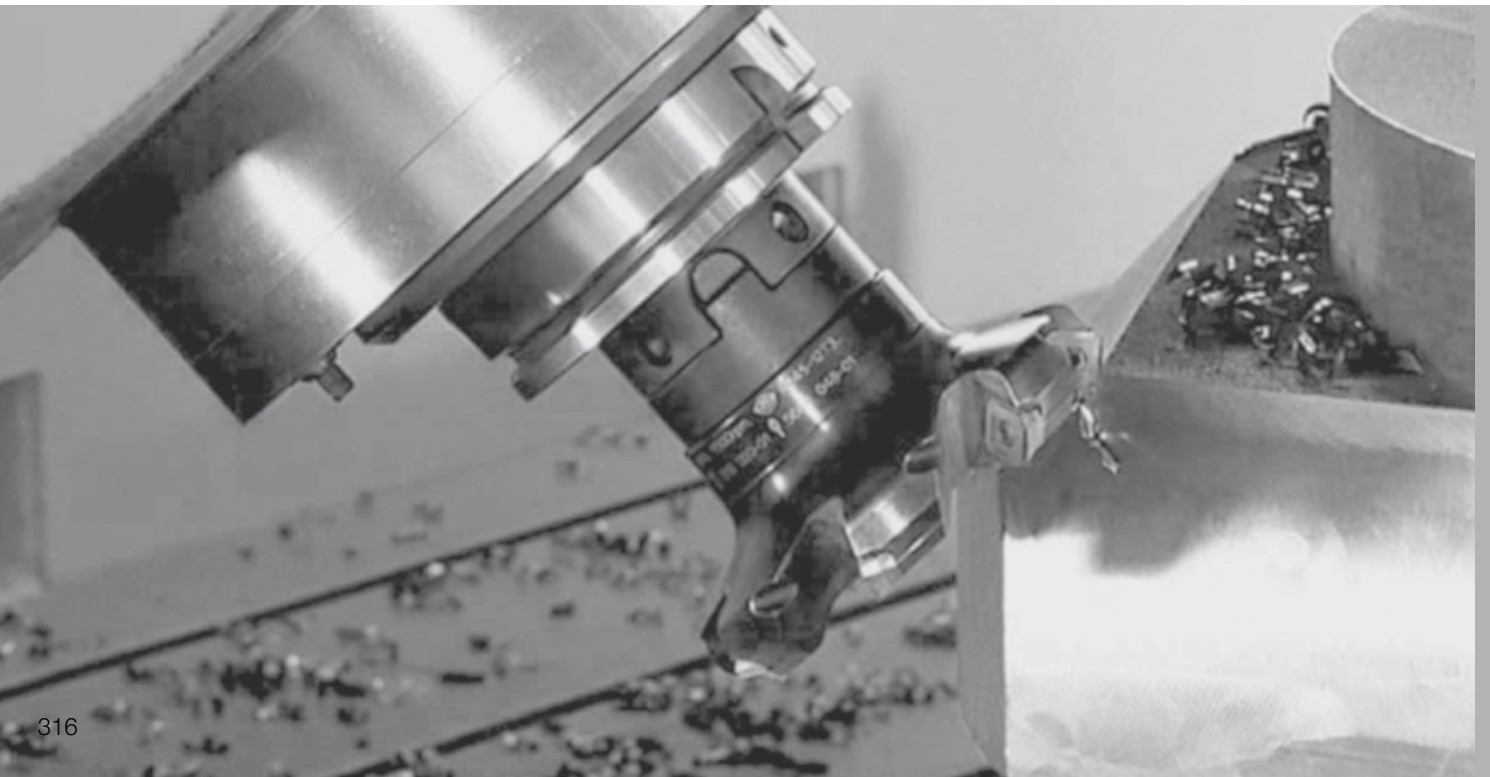

The right gearhead, rack and pinion for every application.

A direct comparison ►

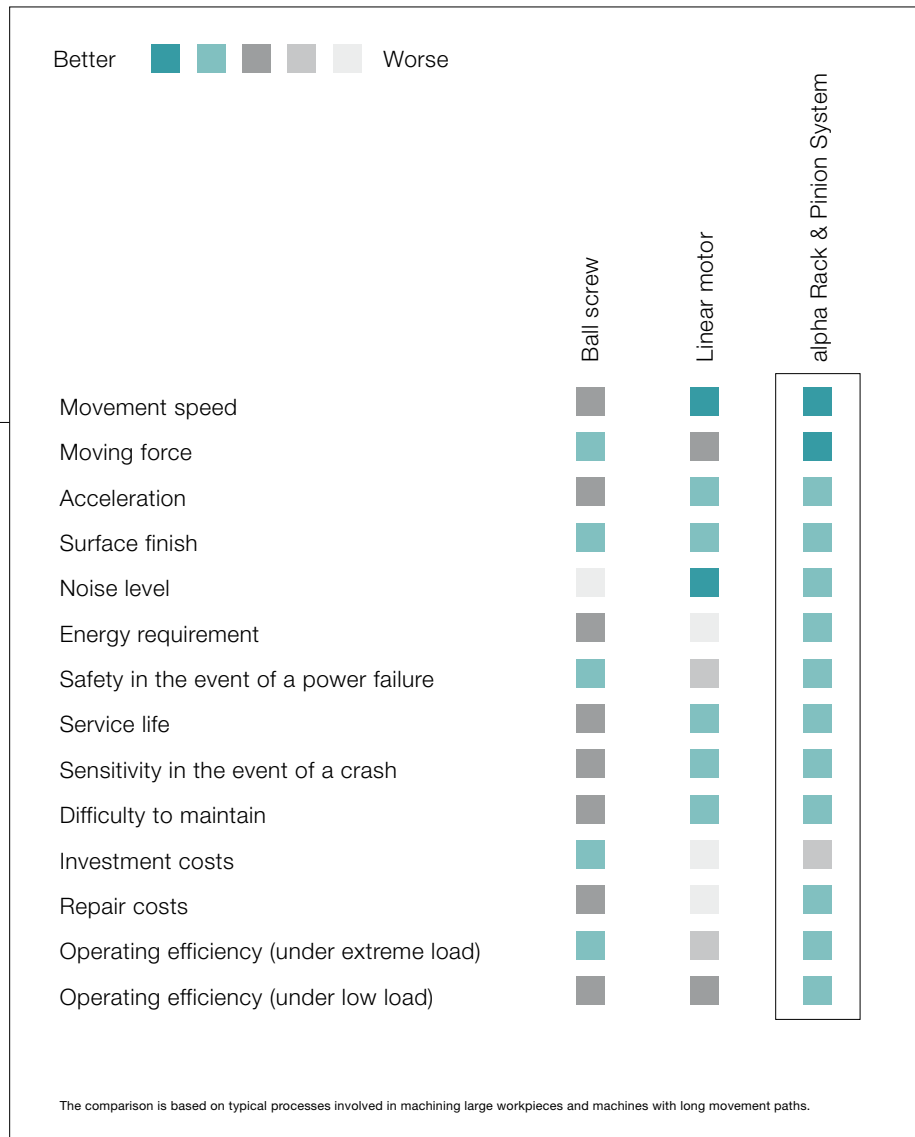

In detail

Feel the dynamics.
Experience the precision.
Maximize efficiency.

Solution-oriented concepts,
sophisticated development
phases and perfect results.
Helping you become a top
performer.

alpha Rack & Pinion Systems
will optimize your applications.
Find out for yourself.
Help your company **take giant
strides towards achieving
its goals.**



Three classes of rack – **unlimited possibilities**

The correct rack is an essential component in realizing your machine concepts. WITTENSTEIN alpha offers three classes of rack Premium Class, Value Class and Smart Class to find the right solution for your application requirements.

Have the freedom to implement your ideas!

Precision System

Premium Class

Solution for **extremely dynamic, precision high-end** applications.

For greater precision: linear and gantry sorting possible.
Contact us!

Standard installation concept:
permanent connection to mounting edge

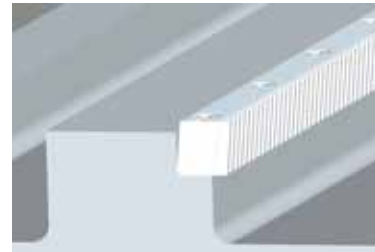

Economy System

Value Class

Solution for **mid-range and economy** applications.



New feature: free connection option

Smart System

Smart Class

The flexible rack for applications **with no available mounting edge in the economy to mid-range** sector.

New: free connection without mounting edge

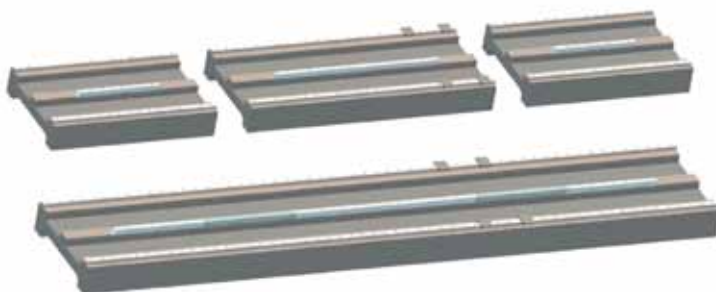

The flexible modular assembly concept makes the Smart Class rack a versatile all-rounder.

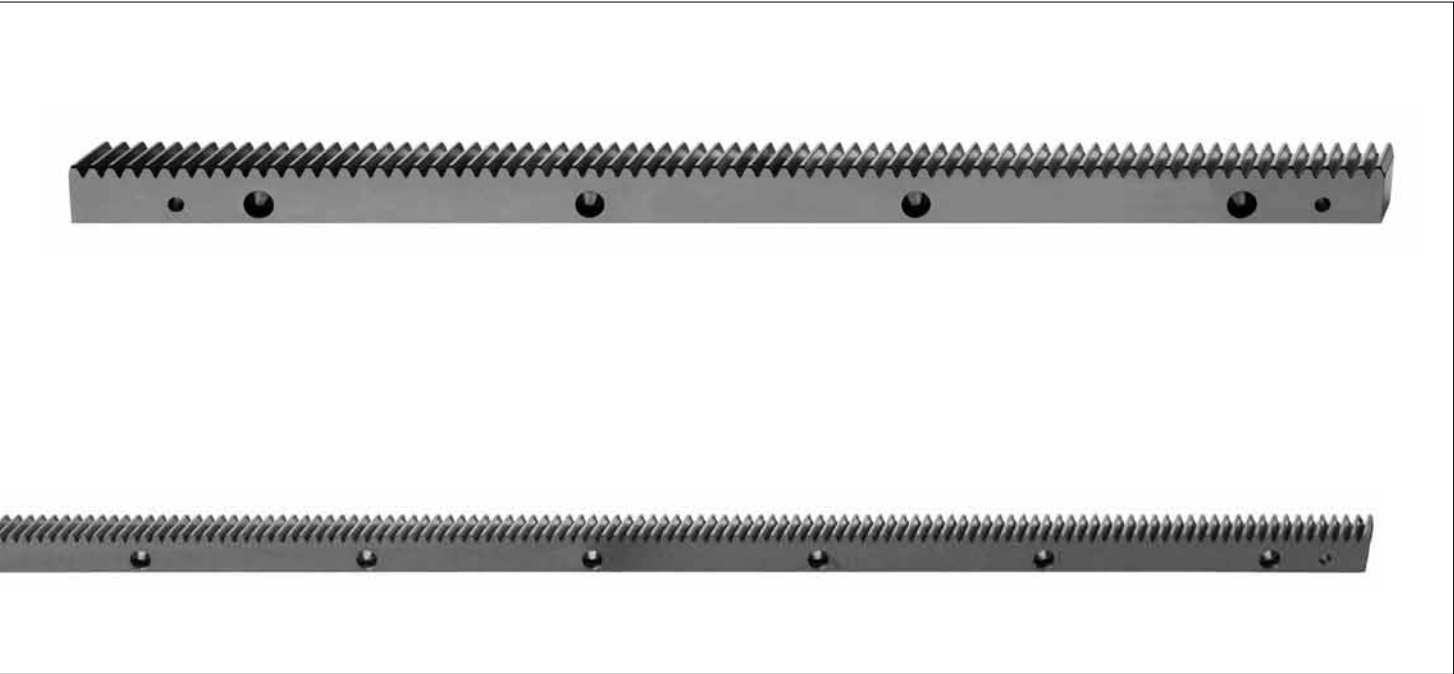

Extremely flexible concept

Free connection concept:

The absence of the mounting edge allows simple and uncomplicated mounting of the rack parallel to the machine guide.

Modular machine concept:

The 60 mm hole pattern and length of 480 mm **are compatible with the hole patterns on linear guides** produced by well-known manufacturers and enable the implementation of modular machine concepts.

Clearing the way for **unlimited movement paths**.



Premium Class rack

Module	p_t	L	z	a^a	a_1	B	d	$d_1^{b)}$	D	$f^{+0.5}$	h	h_b	h_D	H	I	I_1	L_1
2	6.67	500	75	31.7	436.6	24	7	5.7	11	2	22	8	7	24	62.5	125.0	8.5
2	6.67	333	50	31.7	269.9	24	7	5.7	11	2	22	8	7	24	62.5	104.2	8.5
2	6.67	167	25	31.7	103.3	24	7	5.7	11	2	22	8	7	24	62.5	41.7	8.5
3	10	500	50	35.0	430	29	10	7.7	15	2	26	9	9	29	62.5	125.0	10.3
3	10	250	25	35.0	180	29	10	7.7	15	2	26	9	9	29	62.5	125.0	10.3
4	13.33	507	38	18.3	460	39	12	9.7	18	3	35	12	11	39	62.5	125.0 ^{c)}	13.8
5	16.67	500	30	37.5	425	49	14	11.7	20	3	34	12	13	39	62.5	125.0	17.4
6	20	500	25	37.5	425	59	18	15.7	26	3	43	16	17	49	62.5	125.0	20.9

All dimensions in [mm]

Cumulative pitch error Fp: 12 μ m for m2 (500 mm) and m3 (250 mm in length); Fp: 15 μ m for m > 2Single pitch error fp: 3 μ m^{b)} Recommended tolerance dimension: $6^{H7}/8^{H7}/10^{H7}/12^{H7}/16^{H7}$ ^{c)} Hole spacing between two racks on module 4 is 131.67 mm. p_t = Reference circle pitch

z = Number of teeth

m = Module

Value Class rack

Module	p_t	L	z	a^a	a_1	B	d	$d_1^{b)}$	D	$f^{+0.5}$	h	h_b	h_D	H	I	I_1	L_1
2	6.67	1000	150	31.7	936.6	24	7	5.7	11	2	22	8	7	24	62.5	125	8.5
3	10	1000	100	35	930	29	10	7.7	15	2	26	9	9	29	62.5	125	10.3
4	13.33	1000	75	33.3	933.4	39	10	7.7	15	3	35	12	9	39	62.5	125	13.8
5	16.67	1000	60	37.5	925	49	14	11.7	20	3	34	12	13	39	62.5	125	17.4
6	20	1000	50	37.5	925	59	18	15.7	26	3	43	16	17	49	62.5	125	20.9

All dimensions in [mm]

Cumulative pitch error Fp: 35 μ m/1000 mmSingle pitch error fp: 8 μ m; 10 μ m at m5 and m6^{b)} Recommended tolerance dimension: $6^{H7}/8^{H7}/10^{H7}/12^{H7}/16^{H7}$ p_t = Reference circle pitch

z = Number of teeth

m = Module

New feature: free connection option

Smart Class rack

Module	p_t	L	z	a^a	a_1	B	d	$d_1^{b)}$	D	$f^{+0.5}$	h	h_b	h_D	H	I	I_1	L_1
2	6.67	480	72	12	453	24	9	7.7	15	2	2	15.5	8.5	24.2	30	60	8.5
3	10	480	48	10.2	453	29	11	7.7	17	2	3	19.5	10.5	29.2	28.2	60	10.3
4	13.33	480	36	7	452	39	14	9.7	20	3	4	28	13	39.2	23	60	13.8

All dimensions in [mm]

Cumulative pitch error Fp: 30 μ m/500 mmSingle pitch error fp: 6 μ m^{b)} Recommended tolerance dimension: 8^{H7} , 10^{H7} p_t = Reference pitch circle

z = Number of teeth

m = Module

Please refer to the operating instructions available at www.wittenstein-alpha.de/en/ for instructions on assembly and design of the machine bed

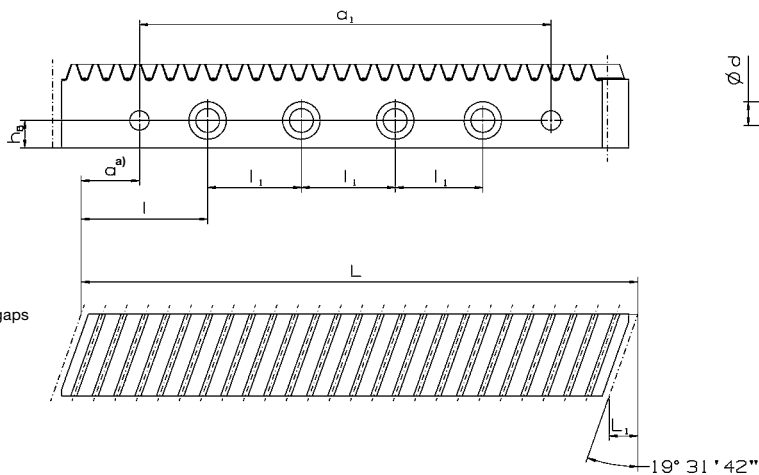
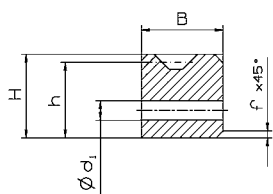

^{a)} Installing several racks leads to small gaps between the individual parts.

Gearing hardened and ground
Profile ground on all sides
Pressure angle $\alpha = 20^\circ$, right-handed

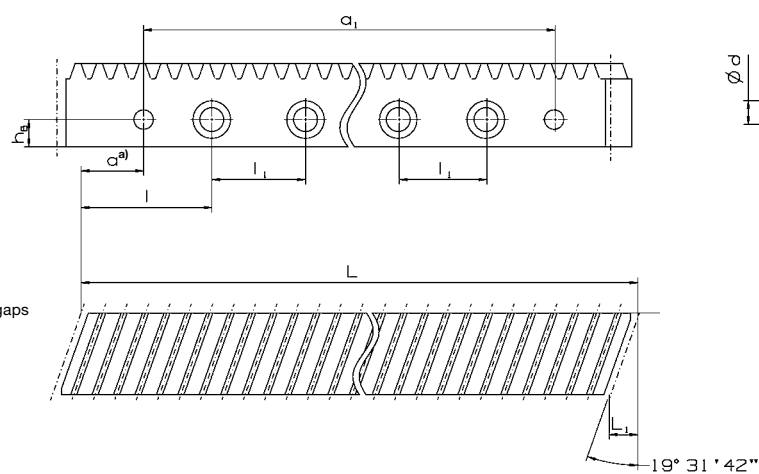
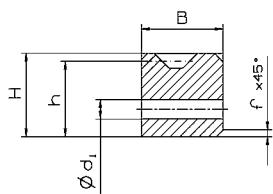

^{a)} Installing several racks leads to small gaps between the individual parts.

Gearing hardened and ground
Profile ground on all sides
Pressure angle $\alpha = 20^\circ$, right-handed

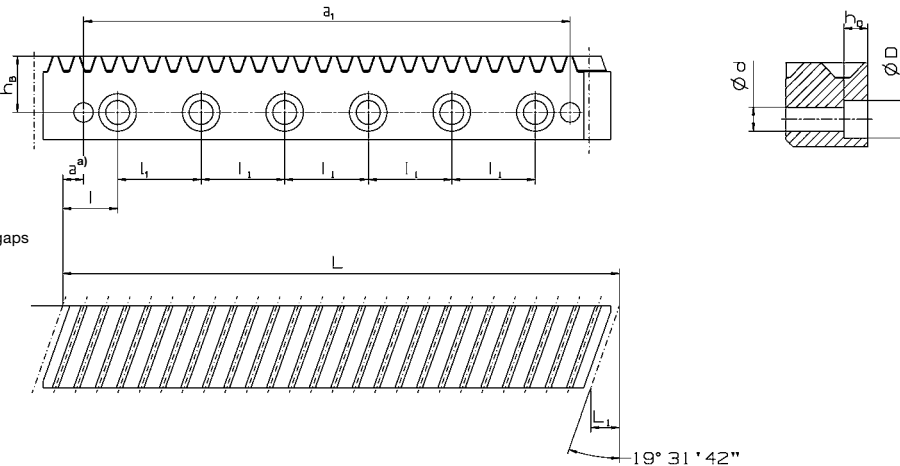
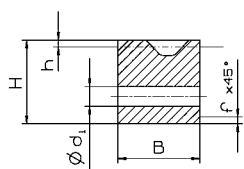

^{a)} Installing several racks leads to small gaps between the individual parts.

Gearing hardened and ground
Profile ground on all sides
Pressure angle $\alpha = 20^\circ$, right-handed

Precision System

Economy System

Smart System



Premium Class+ pinion on TP system output with Premium Class rack

(all pinions, pressure angle $\alpha=20^\circ$, inclination angle $\beta=19,5283^\circ$ left-handed)

TP System output	Module	z	A-PC $\pm 0.3^{a)}$	b	B	d_a	d	x	D1 _{h7}	D6	D7	D14	L7	L12	L13	L14	L15	L16
TP+ 010 (MA, MF)	2	20	44.0	26	24	48.3	42.441	0.4	90	109	118	5.5	7	71.0	50.5	20.5	8.5	38.5
TP+ 025 (MA, MF)	2	20	44.0	26	24	48.3	42.441	0.4	110	135	145	5.5	8	73.5	53.0	24.0	12.0	41.0
	2	40	64.4	26	24	89.2	84.883	0						73.5	53.0	24.0	12.0	41.0
	3	20	59.0	31	29	72.3	63.662	0.4						76.0	52.5	23.5	9.0	38.0
TP+ 050 (MA, MF)	2	40	64.4	26	24	89.2	84.883	0	140	168	179	6.6	10	87.0	66.5	28.5	16.5	54.5
	3	20	59.0	31	29	72.3	63.662	0.4						89.5	66.0	28.0	13.5	51.5
	3	34	80.1	31	29	114.5	108.226	0						90.5	66.0	28.0	13.5	51.5
	4	20	78.2	41	39	94.8	84.882	0.2						97.0	67.5	29.5	10.0	48.0
TP+ 110 (MA, MF)	3	34	80.1	31	29	114.5	108.226	0	200	233	247	9	12	106.0	81.5	31.5	17.0	67.0
	4	20	78.2	41	39	94.8	84.882	0.2						112.5	83.0	33.0	13.5	63.5
	4	30	98.7	41	39	135.6	127.324	0						112.5	83.0	33.0	13.5	63.5
	5	19	86.4	51	49	115.1	100.798	0.4						120.0	85.0	35.0	10.5	60.5
TP+ 300 (MA, MF)	4	30	98.7	41	39	135.6	127.324	0	255	280	300	13.5	18	131.5	102.0	36.0	16.5	82.5
	5	19	86.4	51	49	115.1	100.798	0.4						139.0	104.0	38.0	13.5	79.5
	5	30	113.6	51	49	169.4	159.155	0						135.0	104.0	38.0	13.5	79.5
	6	19	105.9	61	59	138.0	120.958	0.4						142.5	106.0	40.0	10.5	76.5
TP+ 500 (MA, MF)	5	30	113.6	51	49	169.4	159.155	0	285	310	330	13.5	20	147.5	116.5	41.5	17.0	92.0
	6	19	105.9	61	59	138.0	120.958	0.4						155.0	118.5	43.5	14.0	89.0
	6	28	132.1	61	59	190.5	178.254	0						154.0	118.5	43.5	14.0	89.0

All dimensions in [mm]

^{a)} please contact us for precise dimensions;
align mechanism recommended (alignment dimension ± 0.3 mm)

z = Number of teeth

d_a = Tip diameter

d = Partial circle diameter

x = Profile correction

MA = HIGH TORQUE

MF = Standard

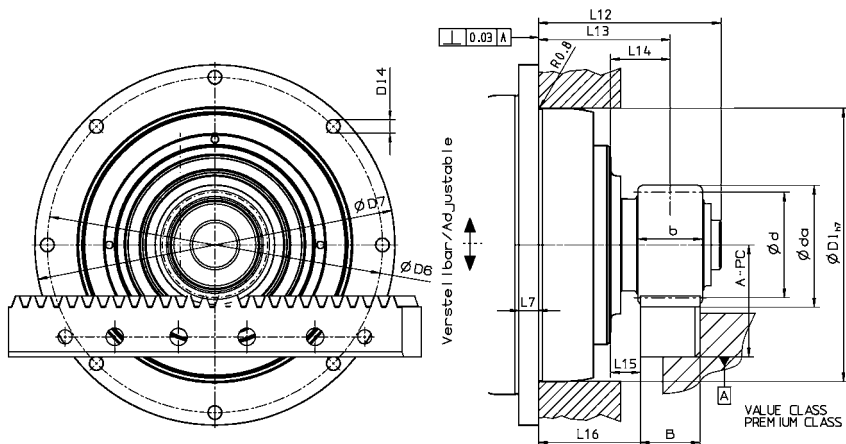

TP+ gearhead with Premium Class+ pinion on TP system output with Premium Class rack

· Technical data for the smallest available ratio

	Module	z	F_{2T}	F_{2T}	T_{2B}	T_{2B}	V_{Max}	V_{Max}	m_{pinion} [kg] (lb _m)
			[N] (lb _f) MF i = 4	[N] (lb _f) MA i = 22	[Nm] (in.lb) MF i = 4	[Nm] (in.lb) MA i = 22	[m/min] (in./sec.) MF i = 4	[m/min] (in./sec.) MA i = 22	
TP+ 010	2	20	2400 (540)	2400 (540)	51 (452)	51 (452)	200 (132)	36 (24)	0.4 (0.9)
TP+ 025	2	20	3400 (765)	3400 (765)	72 (638)	72 (638)	150 (99)	36 (24)	0.4 (0.9)
	2	40	3400 (765)	3400 (765)	144 (1275)	144 (1275)	300 (197)	72 (48)	1.3 (2.9)
	3	20	3400 (765)	3400 (765)	108 (956)	108 (956)	225 (148)	54 (36)	1.0 (2.3)
TP+ 050	2	40	7100 (1598)	7100 (1598)	301 (2664)	301 (2664)	267 (176)	60 (40)	1.3 (2.9)
	3	20	11100 (2498)	11100 (2498)	353 (3125)	353 (3125)	200 (132)	45 (30)	1.0 (2.3)
	3	34	10800 (2430)	10800 (2430)	584 (5169)	584 (5169)	340 (224)	77 (51)	2.4 (5.4)
	4	20	10800 (2430)	10800 (2430)	458 (4054)	458 (4054)	267 (176)	60 (40)	2.0 (4.5)
TP+ 110	3	34	13000 (2925)	13000 (2925)	703 (6222)	703 (6222)	298 (196)	69 (46)	2.4 (5.3)
	4	20	21000 (4725)	21000 (4725)	891 (7886)	891 (7886)	233 (153)	54 (36)	2.0 (4.5)
	4	30	22000 (4950)	22000 (4950)	1401 (12399)	1401 (12399)	350 (230)	81 (54)	3.9 (8.7)
	5	19	21000 (4725)	21000 (4725)	1058 (9364)	1058 (9364)	277 (182)	64 (42)	3.1 (6.9)
	Module	z	i = 20	i = 22	i = 20	i = 22	i = 20	i = 22	
TP+ 300	4	30	22000 (4950)	22000 (4950)	1401 (12399)	1401 (12399)	70 (46)	54 (36)	3.9 (8.7)
	5	19	31000 (6975)	32000 (7200)	1562 (13824)	1646 (14568)	55 (36)	43 (29)	3.1 (6.9)
	5	30	30300 (6818)	30800 (6930)	2411 (21338)	2501 (22136)	88 (58)	68 (45)	10.4 (23)
	6	19	30500 (6863)	30800 (6930)	1845 (16329)	1901 (16825)	67 (44)	51 (34)	5.8 (12.9)
TP+ 500	5	30	34000 (7650)	34000 (7650)	2706 (23949)	2706 (23949)	88 (58)	68 (45)	10.4 (23)
	6	19	41000 (9225)	41600 (9360)	2480 (21948)	2570 (22747)	67 (44)	51 (34)	5.8 (12.9)
	6	28	41000 (9225)	41000 (9225)	3654 (32338)	3654 (32338)	98 (64)	76 (50)	14.5 (32.1)

 Technical data based on 1000 load cycles per hour.
 More combinations possible with cymex®

 F_{2T} = Max. moving force
 T_{2B} = Max. acceleration torque

 MA = HIGH TORQUE
 MF = Standard

In Z-axis without a balancing weight additional load changes can be caused due to additional movements in other axes.

Calculation including load factor:

$$F_{2T} \cdot L_f = F_{2L, LF} < F_{2T}$$

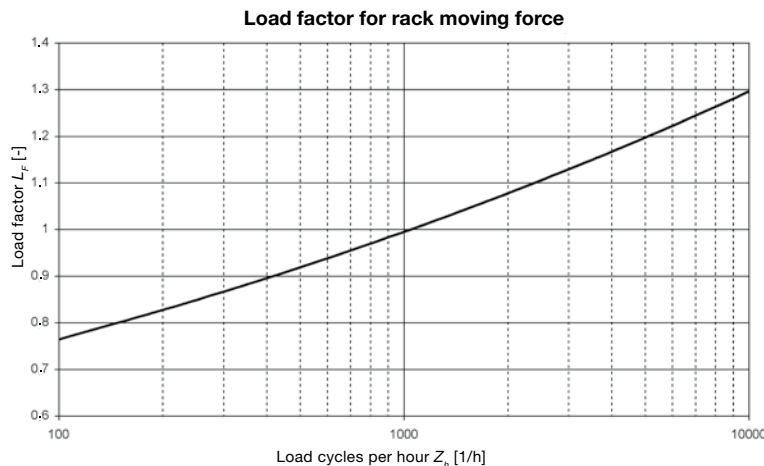

Premium Class RTP pinion on TP output with Premium and Smart Class rack

(all pinions, pressure angle $\alpha=20^\circ$, inclination angle $\beta=19,5283^\circ$ left-handed)

TP output	Module	z	A-PC $\pm 0,3^{b)}$	A-SC $\pm 0,3^{b)}$	b	B	d_a	d	x	D5 _{h7}	D6	D7	D14	L4	L5	L7	L12	L16
TP ⁺ /TK ⁺ 004	2	26	50.4	41.9	26	24	60.7	55.173	0.4	64	79	86	4.5	19.5	8	4	7.2	20.5
TP ⁺ /TK ⁺ / TPK ⁺ 010	2	29 ^{a)}	53.4	44.9	26	24	66.6	61.539	0.3	90	109	118	5.5	40	11	7	8.3	41
	2	33	57.6	49.1	26	24	75.1	70.028	0.3	90	109	118	5.5	30	11	7	8.3	31
	2	37	61.9	53.4	26	24	83.6	78.516	0.3	90	109	118	5.5	30	11	7	8.3	31
TP ⁺ /TK ⁺ / TPK ⁺ 025	2	35 ^{a)}	59.7	51.2	26	24	79.4	74.272	0.3	110	135	145	5.5	39	10	8	8.6	40
	2	40 ^{c)}	65.0	56.5	26	24	90.0	84.882	0.3	110	135	145	5.5	29	10	8	8.6	30
	2	45	70.2	61.7	26	24	100.2	95.493	0.22	110	135	145	5.5	29	10	8	8.6	30
TP ⁺ /TK ⁺ / TPK ⁺ 050	3	31 ^{a)}	76.2	66.7	31	29	106.4	98.676	0.3	140	168	179	6.6	51	14.5	10	11.3	52
	3	35 ^{c)}	82.6	73.1	31	29	119.1	111.409	0.3	140	168	179	6.6	38	14.5	10	11.3	39
	3	40 ^{c)}	90.6	81.1	31	29	135.0	127.324	0.3	140	168	179	6.6	38	14.5	10	11.3	39
TP ⁺ /TK ⁺ / TPK ⁺ 110	4	38	116.6	105.6	41	39	171.3	161.277	0.25	200	233	247	9	50	17.5	12	14.5	51
	4	40 ^{d)}	119.9	108.9	41	39	177.9	169.766	0	200	233	247	9	50	17.5	12	14.5	51
TP ⁺ 300	5	32 ^{a)c)}	120.3	-	51	49	182.6	169.766	0.285	255	280	300	13.5	91	20	18	20	92
TP ⁺ 500	6	31 ^{a)}	143.4	-	61	59	212.8	197.352	0.295	285	310	330	13.5	110	20	20	20	111

All dimensions in [mm]

^{a)} with adapter flange

^{b)} please contact us for precise dimensions;
align mechanism recommended (alignment dimension ± 0.3 mm)

^{c)} also in combination with TP⁺ HIGH TORQUE

^{d)} only in combination with TP⁺ HIGH TORQUE

z = Number of teeth

d_a = Tip diameter

d = Partial circle diameter

x = Profile correction

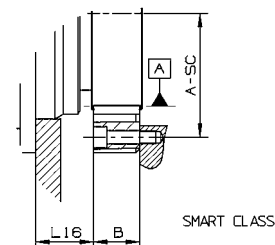
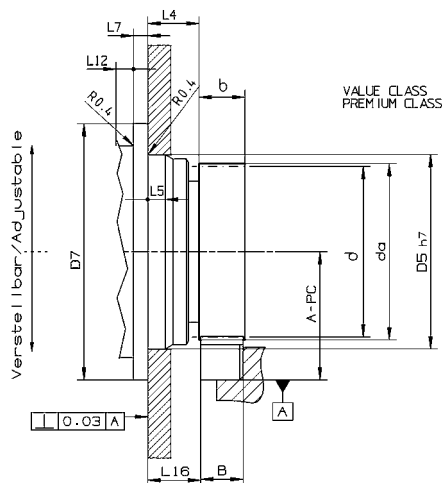
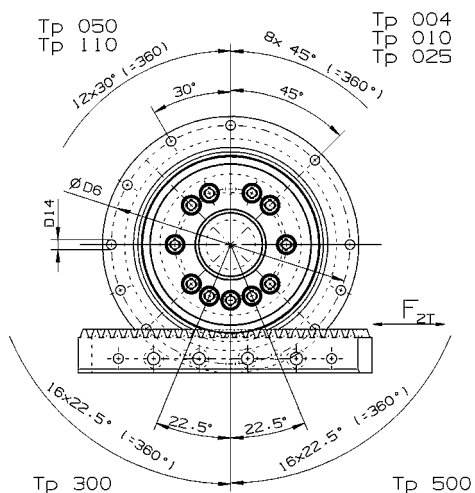

TP+ gearhead with Premium Class RTP pinion on TP output with Premium and Smart Class rack · Technical data for the smallest available ratio

Precision System

	Module	z	F_{2T} [N] (lb _f) MF i = 4 (PC)	F_{2T} [N] (lb _f) MF i = 4 (SC)	F_{2T} [N] (lb _f) MA i = 22 (PC)	F_{2T} [N] (lb _f) MA i = 22 (SC)	T_{2B} [Nm] (in.lb) MF i = 4 (PC)	T_{2B} [Nm] (in.lb) MF i = 4 (SC)	T_{2B} [Nm] (in.lb) MA i = 22 (PC)	T_{2B} [Nm] (in.lb) MA i = 22 (SC)	V_{Max} [m/min] (in/sec) MF i = 4	V_{Max} [m/min] (in/sec) MA i = 22	m_{pinion} [kg] (lb _m)	
TP+ 004	2	26	1400 (315)	1400 (315)	-	-	39 (346)	39 (346)	-	-	255 (168)	-	0.41 (0.91)	
TP+ 010	2	29	2300 (518)	2300 (518)	-	-	71 (629)	71 (629)	-	-	290 (191)	-	0.45 (1)	
	2	33	2550 (574)	2550 (574)	-	-	89 (788)	89 (788)	-	-	330 (217)	-	0.60 (1.33)	
	2	37	2500 (563)	2500 (563)	-	-	98 (868)	98 (868)	-	-	370 (243)	-	0.80 (1.77)	
TP+ 025	2	35	3400 (765)	3400 (765)	-	-	126 (1116)	126 (1116)	-	-	260 (171)	-	0.62 (1.38)	
	2	40 ^{a)}	3700 (833)	3700 (833)	3700 (833)	3700 (833)	157 (1390)	157 (1390)	157 (1390)	157 (1390)	300 (197)	72 (48)	0.85 (1.88)	
	2	45	3600 (810)	3600 (810)	-	-	172 (1523)	172 (1523)	-	-	335 (220)	-	1.15 (2.55)	
TP+ 050	3	31	10800 (24230)	9000 (2025)	-	-	533 (4718)	444 (3930)	-	-	310 (204)	-	1.40 (3.1)	
	3	35 ^{a)}	12000 (2700)	9000 (2025)	12000 (2700)	9000 (2025)	668 (5912)	501 (4434)	668 (5912)	501 (4434)	340 (224)	78 (52)	1.77 (3.92)	
	3	40 ^{a)}	12000 (2700)	9000 (2025)	12000 (2700)	9000 (2025)	764 (6762)	573 (5072)	764 (6762)	573 (5072)	390 (256)	90 (60)	2.50 (5.53)	
TP+ 110	4	38	22000 (4950)	16000 (3600)	-	-	1774 (15700)	1290 (11417)	-	-	440 (289)	-	5.55 (12.27)	
	4	40 ^{b)}	-	-	22000 (4950)	16000 (3600)	-	-	1867 (16523)	1358 (12019)	-	108 (71)	5.24 (11.59)	
	Module	z	i = 20		i = 22		i = 20		i = 22		i = 20		i = 22	
TP+ 300	5	32 ^{a)}	28300 (6368)	-	28300 (6368)	-	2402 (21258)	-	2402 (21258)	-	93 (61)	72 (48)	6.47 (14.30)	
TP+ 500	6	31	36400 (8190)	-	-	-	3592 (31790)	-	-	-	108 (71)	-	12.3 (27.19)	

Smart System

Technical data based on 1000 load cycles per hour.

More combinations possible with cymex®

^{a)} also in combination with TP+ HIGH TORQUE

^{b)} only in combination with TP+ HIGH TORQUE

F_{2T} = Max. moving force

T_{2B} = Max. acceleration torque

SC = Smart Class

PC = Premium Class

MA = HIGH TORQUE

MF = Standard

In Z-axis without a balancing weight additional load changes can be caused due to additional movements in other axes.

Calculation including load factor:

$$F_{2T} \cdot L_f = F_{2L,LF} < F_{2T}$$

Load factor for rack moving force

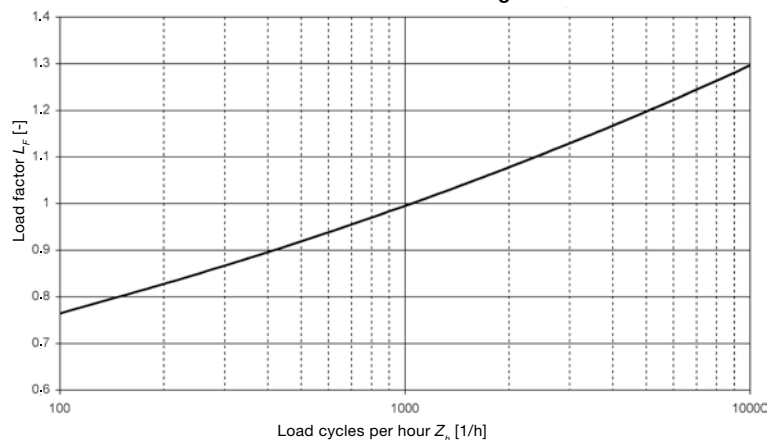

Rack & Pinion



Premium Class+ pinion on SP+ System output with Premium and Smart Class rack

(all pinions, pressure angle $\alpha=20^\circ$, inclination angle $\beta=19,5283^\circ$ left-handed)

SP system output	Module	z	A-PC $\pm 0,3^{a)}$	A-SC $\pm 0,3^{a)}$	b	B	d _a	d	x	D1 ₉₆	D4	D5	L3	L4	L11 ± 1	L12	L13	L14	L15	L16
SP+ 075	2	20	44.0	35.5	26	24	48.3	42.441	0.4	70	6.6	85	20	7	76	61.0	40.5	20.5	8.5	28.5
SP+ 100	2	20	44.0	35.5	26	24	48.3	42.441	0.4	90	9	120	30	10	101	71.5	51.0	21.0	9	39
	2	40	64.4	55.9	26	24	89.2	84.883	0							71.0	51.0	21.0	9	39
	3	20	59.0	49.5	31	29	72.3	63.662	0.4							73.5	54.0	24.0	9.5	39.5
SP+ 140	2	40	64.4	55.9	26	24	89.2	84.883	0	130	11	165	30	12	141	75.0	54.5	24.5	12.5	42.5
	3	20	59.0	49.5	31	29	72.3	63.662	0.4							77.5	54.0	24.0	9.5	39.5
	3	34	80.1	70.6	31	29	114.5	108.226	0							77.0	54.0	24.0	9.5	39.5
	4	20	78.2	67.2	41	39	94.8	84.882	0.2							83.5	59.0	29.0	9.5	39.5
SP+ 180	3	34	80.1	70.6	31	29	114.5	108.226	0	160	13.5	215	30	15	182	82.0	57.5	27.5	13	43
	4	20	78.2	67.2	41	39	94.8	84.882	0.2							88.5	59.0	29.0	9.5	39.5
	4	30	98.7	87.7	41	39	135.6	127.324	0							87.0	59.0	29.0	9.5	39.5
	5	19	86.4	-	51	49	115.1	100.798	0.4							94.5	64.5	34.5	10	40
SP+ 210	4	30	98.7	87.7	41	39	135.6	127.324	0	180	17	250	38	17	215	99.9	70.4	32.5	13	50.9
	5	19	86.4	-	51	49	115.1	100.798	0.4							107.4	72.4	34.5	10	47.9
	5	30	113.6	-	51	49	169.4	159.155	0							105.9	72.4	34.5	10	47.9
	6	19	105.9	-	61	59	138.0	120.958	0.4							113.4	77.9	40.0	10.5	48.4
SP+ 240	5	30	113.6	-	51	49	169.4	159.155	0	200	17	290	40	20	242	109.9	78.9	39.0	14.5	54.4
	6	19	105.9	-	61	59	138.0	120.958	0.4							120.9	80.9	41.0	11.5	51.4
	6	28	132.1	-	61	59	190.5	178.254	0							119.9	80.9	41.0	11.5	51.4

All dimensions in [mm]

^{a)} please contact us for precise dimensions;

align mechanism recommended (alignment dimension ± 0.3 mm)

z = Number of teeth

d_a = Tip diameter

d = Partial circle diameter

x = Profile correction

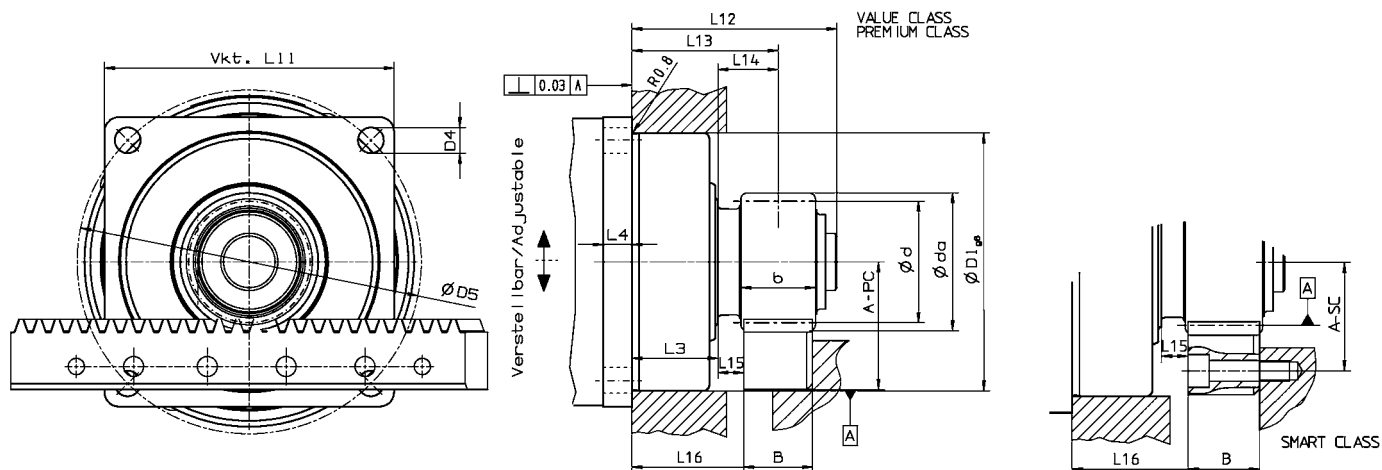

SP+ gearhead with Premium+ pinion on SP+ system output with Premium and Smart Class rack · Technical data for the smallest available ratio

	Module	z	F_{2T} [N] (lb.) i = 4 (PC)	F_{2T} [N] (lb.) i = 4 (SC)	F_{2T} [N] (lb.) i = 16 (PC)	F_{2T} [N] (lb.) i = 16 (SC)	T_{2B} [Nm] (in.lb) i = 4 (PC)	T_{2B} [Nm] (in.lb) i = 4 (SC)	T_{2B} [Nm] (in.lb) i = 16 (PC)	T_{2B} [Nm] (in.lb) i = 16 (SC)	V_{Max} [m/min] (in./sec) i = 4	V_{Max} [m/min] (in./sec) i = 16	m_{pinion} [kg] (lb. _m)
SP+ 075	2	20	3300 (743)	3300 (743)	3300 (743)	3300 (743)	68 (602)	68 (602)	68 (602)	68 (602)	200 (132)	50 (33)	0.4 (0.89)
SP+ 100	2	20	6400 (1440)	5000 (1125)	6400 (1440)	5000 (1125)	136 (1204)	106 (939)	136 (1204)	106 (939)	150 (99)	37 (25)	0.4 (0.89)
	2	40	6100 (1373)	5000 (1125)	6100 (1373)	5000 (1125)	259 (2293)	212 (1877)	259 (2293)	212 (1877)	300 (197)	75 (50)	1.3 (2.88)
	3	20	6000 (1350)	6000 (1350)	6000 (1350)	6000 (1350)	191 (1691)	191 (1691)	191 (1691)	191 (1691)	225 (148)	56 (37)	1.0 (2.21)
SP+ 140	2	40	7100 (1598)	5000 (1125)	7100 (1598)	5000 (1125)	301 (2664)	212 (1877)	301 (2664)	212 (1877)	266 (175)	66 (44)	1.3 (2.88)
	3	20	10000 (2250)	9000 (2025)	10000 (2250)	9000 (2025)	318 (2815)	286 (2532)	318 (2815)	286 (2532)	200 (132)	50 (33)	1.0 (2.21)
	3	34	9800 (2205)	9000 (2025)	9800 (2205)	9000 (2025)	530 (4691)	487 (4310)	530 (4691)	487 (4310)	340 (224)	85 (56)	2.4 (5.31)
	4	20	9400 (2115)	9400 (2115)	9400 (2115)	9400 (2115)	399 (3532)	399 (3532)	399 (3532)	399 (3532)	266 (175)	66 (44)	2.0 (4.42)
SP+ 180	3	34	13600 (3060)	9000 (2025)	13600 (3060)	9000 (2025)	736 (6514)	487 (4310)	736 (6514)	487 (4310)	297 (195)	85 (56)	2.4 (5.31)
	4	20	13600 (3060)	13600 (3060)	13600 (3060)	13600 (3060)	577 (5107)	577 (5107)	577 (5107)	577 (5107)	233 (153)	66 (44)	2.0 (4.42)
	4	30	13200 (2970)	13200 (2970)	13200 (2970)	13200 (2970)	840 (7434)	840 (7434)	840 (7434)	840 (7434)	350 (230)	100 (66)	3.9 (8.62)
	5	19	12800 (2880)	-	12800 (2880)	-	645 (5709)	-	645 (5709)	-	277 (182)	78 (52)	3.1 (6.86)
SP+ 210	4	30	21700 (4883)	16000 (3600)	21700 (4883)	16000 (3600)	1381 (1222)	1019 (9019)	1381 (12222)	1019 (9019)	250 (164)	87 (58)	2.0 (4.42)
	5	19	21800 (4905)	-	21800 (4905)	-	1099 (9727)	-	1099 (9727)	-	197 (130)	69 (46)	3.9 (8.62)
	5	30	21000 (4725)	-	21000 (4725)	-	1671 (14789)	-	1671 (14789)	-	312 (205)	109 (72)	3.1 (6.86)
	6	19	20600 (4635)	-	20600 (4635)	-	1246 (11028)	-	1246 (11028)	-	237 (156)	83 (55)	10.4 (22.99)
SP+ 240	5	30	31700 (7133)	-	31700 (7133)	-	2523 (22329)	-	2523 (22329)	-	275 (181)	109 (72)	10.4 (22.99)
	6	19	32000 (7200)	-	32000 (7200)	-	1935 (17125)	-	1935 (17125)	-	209 (138)	83 (55)	5.8 (12.82)
	6	28	31000 (697)	-	31000 (6975)	-	2763 (24453)	-	2763 (24453)	-	308 (203)	122 (81)	14.5 (32.05)

Technical data based on 1000 load cycles per hour.
More combinations possible with cymex®

F_{2T} = Max. moving force
 T_{2B} = Max. acceleration torque

In Z-axis without a balancing weight additional load changes can be caused due to additional movements in other axes.

Calculation including load factor:
 $F_{2T} * L_f = F_{2L,LF} < F_{2T}$

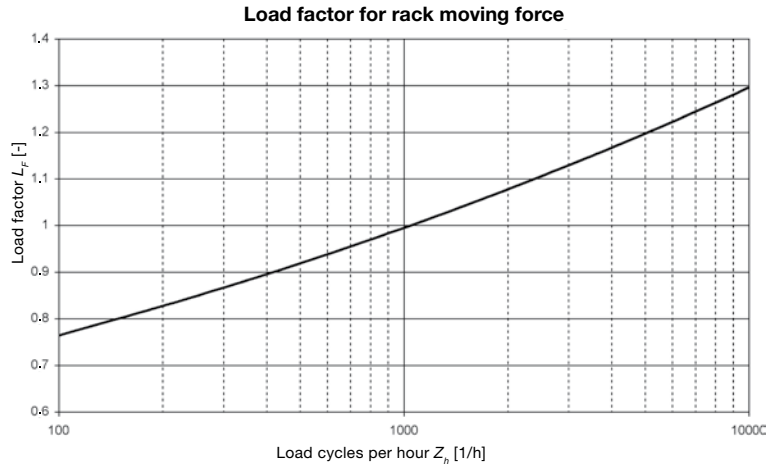

Precision System

Smart System

Rack & Pinion



Standard Class RSP pinion with SP involute output with Value and Smart Class rack

(all pinions, pressure angle $\alpha=20^\circ$, inclination angle $\beta=19,5283^\circ$ left-handed)

Output with SP involute tooting DIN5480	Module	z	A-VC $\pm 0.3^{a)}$	A-SC $\pm 0.3^{a)}$	b	B	d _a	d	x	D1 _{g6}	D4	D5	L3	L4	L11 ± 1	L12	L16	L23
SP*/SK* 060	2	15	38.9	30.4	26	24	37.8	31.831	0.5	60	5.5	68	20	6	62	2	27	32
	2	16	40.0	31.5	26	24	40.0	33.953	0.5	60	5.5	68	20	6	62	2	27	32
	2	18	41.9	33.4	26	24	43.8	38.197	0.4	60	5.5	68	20	6	62	2	27	32
SP*/SK*/SPK* 075 VDS 050	2	18	41.9	33.4	26	24	43.8	38.197	0.4	70	6.6	85	20	7	76	2.5	28	33
	2	20	44.0	35.5	26	24	48.1	42.441	0.4	70	6.6	85	20	7	76	2.5	28	33
	2	22	46.1	37.6	26	24	52.3	46.686	0.4	70	6.6	85	20	7	76	2.5	28	33
SP*/SK*/SPK* 100 VDS 063	2	23	47.2	38.7	26	24	54.4	48.808	0.4	90	9	120	30	10	101	3	39	34
	2	25	49.3	40.8	26	24	58.6	53.052	0.4	90	9	120	30	10	101	3	39	34
	2	27	51.2	42.7	26	24	62.5	57.296	0.3	90	9	120	30	10	101	3	39	34
SP*/SK*/SPK* 140 VDS 080	3	20	59.0	49.5	31	29	71.7	63.662	0.4	130	11	165	30	12	141	3	51	51
	3	22	62.2	52.7	31	29	78.3	70.028	0.4	130	11	165	30	12	141	3	51	51
	3	24	65.4	55.9	31	29	84.7	76.394	0.4	130	11	165	30	12	141	3	51	51
SP*/SK*/SPK* 180 VDS 100	4	20	79.0	68.0	41	39	96.1	84.883	0.4	160	13.5	215	30	15	182	3	44	54
SP* 210	4	25	89.4	78.4	41	39	116.8	106.103	0.34	180	17	250	38	17	215	3	63	65
SP* 240	5	24	99.4	-	51	49	140.8	127.324	0.35	200	17	290	40	20	242	3	63	73

All dimensions in [mm]

^{a)} please contact us for precise dimensions;

align mechanism recommended (alignment dimension ± 0.3 mm)

z = Number of teeth

d_a = Tip diameter

d = Partial circle diameter

x = Profile correction

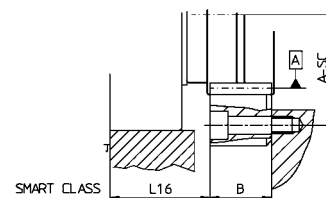
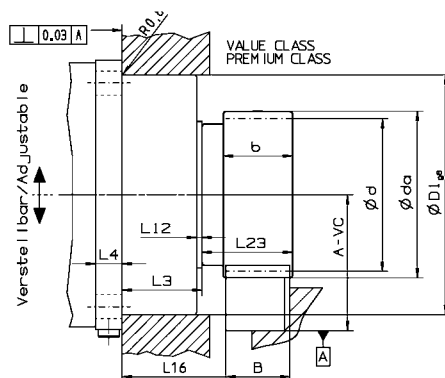
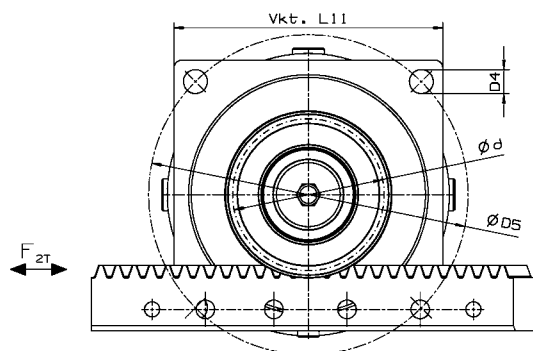

SP+ gearhead with Standard Class RSP pinion on SP involute output with Value and Smart Class rack · Technical data for the smallest available ratio

	Module	z	F_{2T}	F_{2T}	F_{2T}	F_{2T}	T_{2B}	T_{2B}	T_{2B}	T_{2B}	V_{Max}	V_{Max}	m_{pinion}
			[N] (lb _f) i = 3 (VC)	[N] (lb _f) i = 3 (SC)	[N] (lb _f) i = 16 (VC)	[N] (lb _f) i = 16 (SC)	[Nm] (in.lb) i = 3 (VC)	[Nm] (in.lb) i = 3 (SC)	[Nm] (in.lb)] i = 16 (VC)	[Nm] (in.lb)] i = 16 (SC)	[m/min] (in/sec) i = 3	[m/min] (in/sec) i = 16	[kg] (lb _m)
SP+ 060	2	15	1800 (405)	1800 (405)	2300 (518)	2300 (518)	29 (257)	29 (257)	37 (328)	37 (328)	200 (132)	37 (25)	0.18 (0.4)
	2	16	1700 (383)	1700 (383)	2300 (518)	2300 (518)	29 (257)	29 (257)	39 (346)	39 (346)	210 (138)	40 (27)	0.19 (0.42)
	2	18	1500 (338)	1500 (338)	2300 (518)	2300 (518)	29 (257)	29 (257)	44 (390)	44 (390)	240 (158)	45 (30)	0.23 (0.51)
SP+ 075	2	18	3300 (743)	3300 (743)	3300 (743)	3300 (743)	63 (558)	63 (558)	63 (558)	63 (558)	240 (158)	45 (30)	0.20 (0.45)
	2	20	3300 (743)	3300 (743)	3300 (743)	3300 (743)	70 (620)	70 (620)	70 (620)	70 (620)	260 (171)	50 (33)	0.26 (0.58)
	2	22	3300 (743)	3300 (743)	3300 (743)	3300 (743)	77 (682)	77 (682)	77 (682)	77 (682)	290 (191)	55 (37)	0.32 (0.71)
SP+ 100	2	23	4300 (968)	5000 (1125)	4300 (968)	5000 (1125)	105 (930)	122 (1080)	105 (930)	122 (1080)	230 (151)	43 (29)	0.29 (0.65)
	2	25	4300 (968)	5000 (1125)	4300 (968)	5000 (1125)	114 (1009)	133 (1178)	114 (1009)	133 (1178)	250 (164)	47 (31)	0.31 (0.69)
	2	27	4300 (968)	5000 (1125)	4300 (968)	5000 (1125)	123 (1089)	143 (1266)	123 (1089)	143 (1266)	270 (178)	51 (34)	0.46 (1.02)
SP+ 140	3	20	8000 (1800)	9000 (2025)	8000 (1800)	9000 (2025)	255 (2257)	286 (2532)	255 (2257)	286 (2532)	260 (171)	50 (33)	0.72 (1.60)
	3	22	8000 (1800)	9000 (2025)	8000 (1800)	9000 (2025)	280 (2478)	315 (2788)	280 (2478)	315 (2788)	290 (191)	55 (37)	0.98 (2.17)
	3	24	8000 (1800)	9000 (2025)	8000 (1800)	9000 (2025)	306 (2709)	344 (3045)	306 (2709)	344 (3045)	320 (210)	60 (40)	1.26 (2.79)
SP+ 180	4	20	13000 (2925)	13000 (2925)	13000 (2925)	13000 (2925)	552 (4886)	552 (4886)	552 (4886)	552 (4886)	310 (204)	66 (44)	1.38 (3.05)
SP+ 210	4	25	14000 (3150)	16000 (3600)	14000 (3150)	16000 (3600)	743 (6576)	849 (7514)	743 (6576)	849 (7514)	270 (178)	72 (48)	2.24 (4.96)
SP+ 240	5	24	22000 (4950)	-	22000 (4950)	-	1401 (12399)	-	1401 (12399)	-	290 (191)	87 (58)	3.96 (8.76)

Technical data based on 1000 load cycles per hour.
More combinations possible with cymex®

F_{2T} = Max. moving force
 T_{2B} = Max. acceleration torque
SC = Smart Class
VC = Value Class

In Z-axis without a balancing weight additional load changes can be caused due to additional movements in other axes.

Calculation including load factor:

$$F_{2T} \cdot L_f = F_{2L, LF} < F_{2T}$$

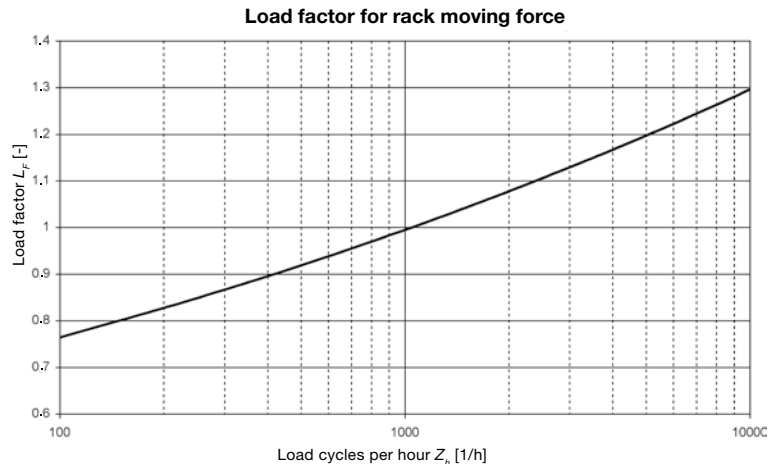

Economy+ System

Smart System

Rack & Pinion



Value Class pinion (shrunk/bonded) on shaft key with Value and Smart Class rack

(all pinions, pressure angle $\alpha=20^\circ$, inclination angle $\beta=19,5283^\circ$ left-handed)

Key output	Module	z	A-VC $\pm 0.3^a)$	A-SC $\pm 0.3^a)$	b	B	d_a	d	x	D1 _{g6}	D4	D5	D7	L3	L4	L11	L12	L13	L14	L15	L16
SP ⁺ /SK ⁺ 060	2	18	41.9	33.4	26	24	43.7	38.197	0.4	60	5.5	68	0	20	6	62	54	39	19	7	27
SP ⁺ /SK ⁺ / SPK ⁺ 075 VDS 050	2	22	45.7	37.2	26	24	51.4	46.686	0.2	70	6.6	85	40	20	7	76	62	40	20	8	28
SP ⁺ /SK ⁺ / SPK ⁺ 100 VDS 063	2	26	49.6	41.1	26	24	59.1	55.174	0	90	9	120	45	30	10	101	95.5	51	21	9	39
SP ⁺ /SK ⁺ / SPK ⁺ 140 VDS 080	3	24	64.2	54.7	31	29	82.3	76.395	0	130	11	165	58	30	12	141	122	65.5	35.5	21	51

All dimensions in [mm]

^{a)} please contact us for precise dimensions;

align mechanism recommended (alignment dimension ± 0.3 mm)

z = Number of teeth

d_a = Tip diameter

d = Partial circle diameter

x = Profile correction

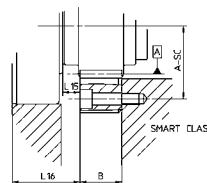
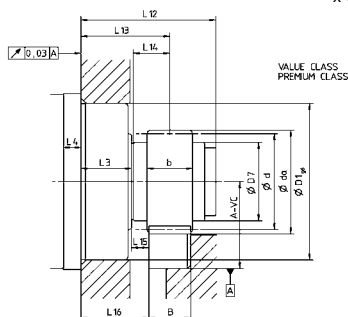
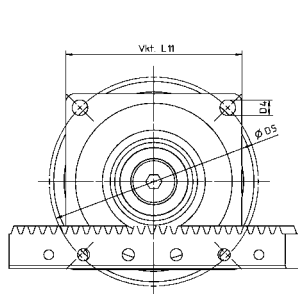

Value Class pinion (shrunk/bonded) on shaft key with Value and Smart Class rack

(all pinions, pressure angle $\alpha=20^\circ$, inclination angle $\beta=19,5283^\circ$ left-handed)

Key output	Module	z	A-VC $\pm 0.3^a)$	A-SC $\pm 0.3^a)$	b	B	d_a	d	x	D1 _{h6}	D4	D5	D7	L3	L12	L13	L14	L15	L16
LP ⁺ /LK ⁺ / LPK ⁺ 070	2	18	41.9	33.4	26	24	43.7	38.197	0.4	52	M5	62	0	5	42	27	19	7	15
LP ⁺ /LK ⁺ / LPK ⁺ 090	2	22	45.7	37.2	26	24	51.4	46.686	0.2	68	M6	80	40	5	52	30	20	8	18
LP ⁺ /LK ⁺ / LPK ⁺ 120	2	26	49.6	41.1	26	24	59.1	55.174	0	90	M8	108	45	6	77.5	33	21	9	21
LP ⁺ /LK ⁺ / LPK ⁺ 155	3	24	64.2	54.7	31	29	82.3	76.395	0	120	M10	140	58	8	107	50.5	35.5	21	36

All dimensions in [mm]

^{a)} please contact us for precise dimensions;

align mechanism recommended (alignment dimension ± 0.3 mm)

z = Number of teeth

d_a = Tip diameter

d = Partial circle diameter

x = Profile correction

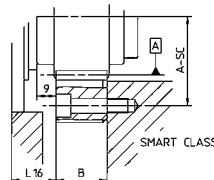
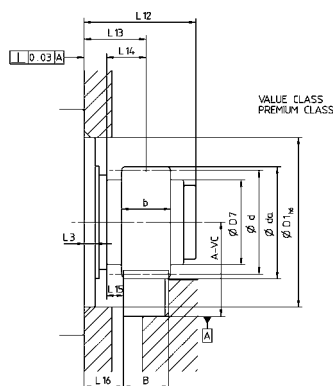
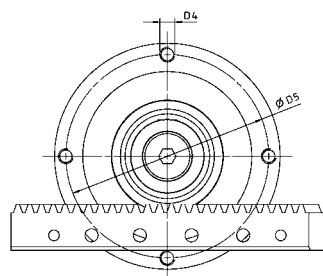

SP+ gearhead with Value Class pinion on shaft key with Value and Smart Class rack

	Ratio	Module	z	F_{2T} [N] (lb _f) (VC)	F_{2T} [N] (lb _f) (SC)	T_{2B} [Nm] (in.lb) (VC)	T_{2B} [Nm] (in.lb) (SC)	$F_{2T Not}$ [N] (lb _f)	$T_{2 Not}$ [Nm] (lb _f)	V_{Max} [m/min] (in/sec) i = 5	V_{Max} [m/min] (in/sec) i = 25	m_{pinion} [kg] (lb _m)
SP+ 060	3	2	18	1550 (338)	1550 (349)	30 (266)	30 (266)	3000 (675)	57 (505)	-	-	0.3 (0.67)
	10, 100	2	18	1650 (372)	1650 (372)	32 (284)	32 (284)	3000 (675)	57 (505)	-	-	0.3 (0.67)
	4-7 / 16-70	2	18	2000 (450)	2000 (450)	38 (337)	38 (337)	3000 (675)	57 (505)	144 (95)	29 (20)	0.3 (0.67)
SP+ 075	All	2	22	3500 (788)	3500 (788)	82 (726)	82 (726)	5000 (1125)	117 (1036)	176 (116)	35 (23)	0.4 (0.89)
SP+ 100	All	2	26	4300 (968)	5000 (1125)	119 (1054)	138 (1222)	8500 (1913)	234 (2071)	156 (103)	31 (21)	0.6 (1.33)
SP+ 140	All	3	24	8000 (1800)	9000 (2025)	306 (2709)	344 (3045)	16000 (3600)	611 (5408)	192 (126)	38 (25)	1.6 (3.54)

Technical data based on 1000 load cycles per hour.
More combinations possible with cymex®

F_{2T} = Max. moving force
 T_{2B} = Max. acceleration torque
SC = Smart Class
VC = Value Class

In Z-axis without a balancing weight additional load changes can be caused due to additional movements in other axes.

Calculation including load factor:
 $F_{2t} * L_f = F_{2t, LF} < F_{2T}$

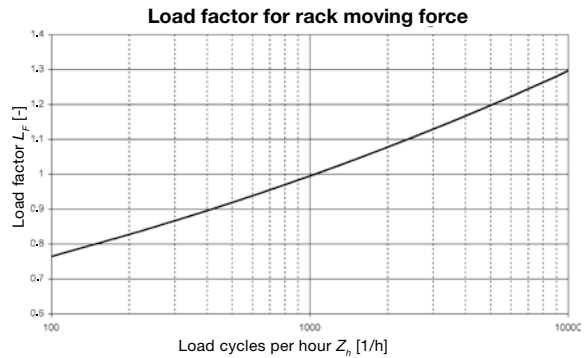

LP+ gearhead with Value Class pinion on shaft key with Value and Smart Class rack

	Ratio	Module	z	F_{2T} [N] (lb _f) (VC)	F_{2T} [N] (lb _f) (SC)	T_{2B} [Nm] (in.lb) (VC)	T_{2B} [Nm] (in.lb) (SC)	$F_{2T Not}$ [N] (lb _f)	$T_{2 Not}$ [Nm] (lb _f)	V_{Max} [m/min] (in/sec) i = 5	V_{Max} [m/min] (in/sec) i = 25	m_{pinion} [kg] (lb _m)
LP+ 070	3, 10, 15, 30, 100	2	18	1700 (383)	1700 (383)	32 (284)	32 (284)	2700 (608)	52 (461)	-	-	0.3 (0.67)
	5, 7, 25, 50	2	18	1850 (417)	1850 (417)	35 (310)	35 (310)	2700 (608)	52 (461)	144 (95)	29 (20)	0.3 (0.67)
LP+ 090	3, 10, 15, 30, 100	2	22	3400 (765)	3400 (765)	79 (700)	79 (700)	4800 (1080)	112 (992)	-	-	0.4 (0.89)
	5, 7, 25, 50	2	22	3500 (788)	3500 (788)	82 (726)	82 (726)	4800 (1080)	112 (992)	176 (116)	35 (23)	0.4 (0.89)
LP+ 120	All	2	26	4100 (923)	4500 (1013)	113 (1001)	124 (1098)	7800 (1755)	215 (1903)	156 (103)	31 (21)	0.6 (1.33)
LP+ 155	All	3	24	6500 (1463)	7000 (1575)	248 (2195)	267 (2363)	14000 (3150)	535 (4735)	192 (126)	38 (25)	1.6 (3.54)

Technical data based on 1000 load cycles per hour.
More combinations possible with cymex®

F_{2T} = Max. moving force
 T_{2B} = Max. acceleration torque
SC = Smart Class
VC = Value Class

In Z-axis without a balancing weight additional load changes can be caused due to additional movements in other axes.

Calculation including load factor:
 $F_{2t} * L_f = F_{2t, LF} < F_{2T}$

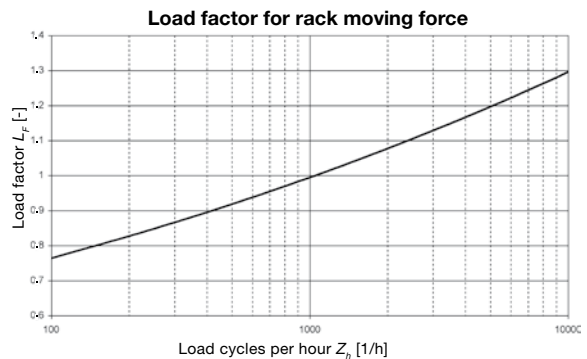

Lubrication system

Perfect lubrication – for a perfect system

Efficient lubrication systems are essential in guaranteeing **a long service life** for our pinion and rack systems.

We offer you the right **felt pinions, fastening axles and lubricator sets**, adapted perfectly to our components. The lubricator supplies a preset quantity of grease to the felt pinion and guarantees a constant film of lubrication on the rack and pinion.

Complete lubrication system

Complete lubricator

Kit order number	Size
20021555	125
20022531	475

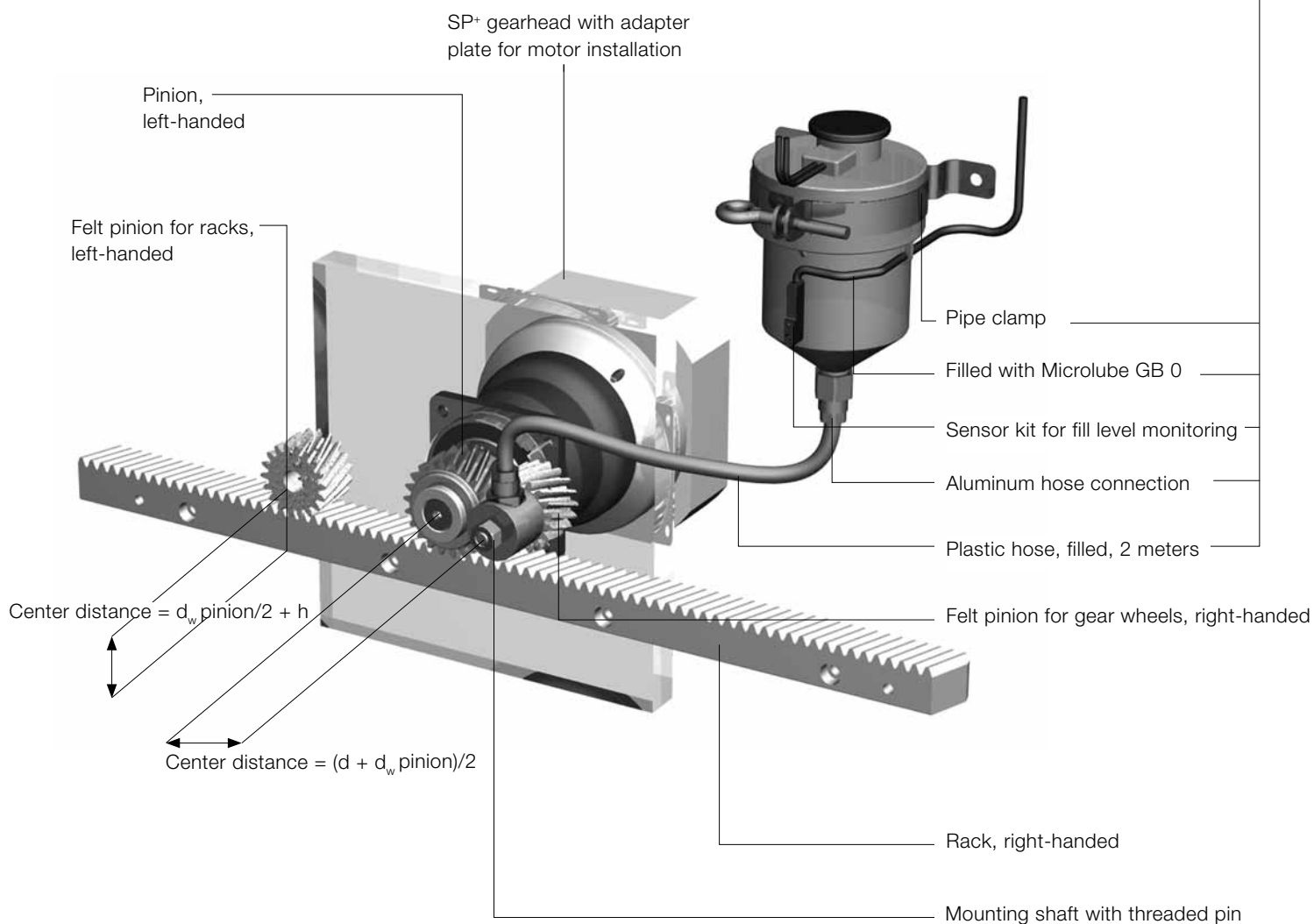

Replacement sensor for fill level monitoring

Lubricator type	Order number
125	20021557
475	20022535

The **sensor kit for fill level monitoring** included in the lubricator set enables your machine to permanently monitor the fill level in the lubricator so you utilize it more efficiently.

Felt pinion, helical-toothed

	Felt pinion							Fastening axle C					
	Module	Number of teeth	Order no.	d	d _i	d _k	b	Order no.	D	S	b	l	L
A	2	18 LH	20022364	38.2	12	42	25	20017836	30	M8	25.5	10	60
B	2	18 RH	20017681										
A	3	18 LH	20022359	57.3	12	63	30	20021477	30	M8	30.5	10	65
B	3	18 RH	20021473										
A	4	18 LH	20023115	76.4	12	84.4	40	20023119	30	M8	40.5	10	75
B	4	18 RH	20023106										
A	5	17 LH	20023116	90.2	20	100.2	50	20023120	50	M12	50.5	15	90
B	5	17 RH	20023111										
A	6	17 LH	20023117	108.2	20	120.2	60	20023121	50	M12	60.5	15	100
B	6	17 RH	20023113										

All dimensions in [mm]

B Felt pinion for pinions, right-handed RH



A Felt pinion for Racks, left-handed LH

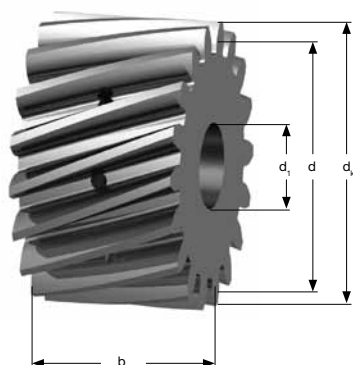

C Fastening axis for felt pinions

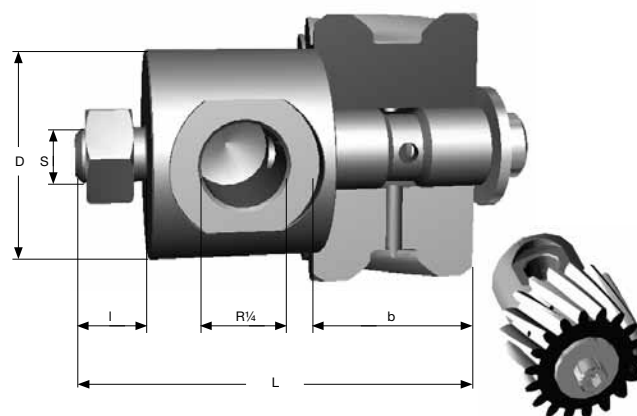

Lubrication system

Dimensions of the lubricator

Kit order number	Size	D	D ₁	D ₂ ^{a)}	D ₃ ^{a)}	L	L ₁	A ₁	A ₂	Replacement lubricator ^{b)}
20021555	125	80	68	R ¼"	6,5	114	13,5	95	48	20021556
20022531	475	115	103	R ½"	8,5	155	20	105	70	20022533

All dimensions in [mm]

^{a)} Lubricator connector

^{b)} No pipe clamp, hose, screw connection, synchronous cable or sensor kit

Nitrogen gas is generated in the electronically controlled lubricator. When the micro switches initiate the required dose, the nitrogen gas generated moves the piston continually. An emptying time of 1, 2, 3, 6, 12 or 18 months and individual lubricant quantities can be selected. Each product is supplied with detailed operating instructions.

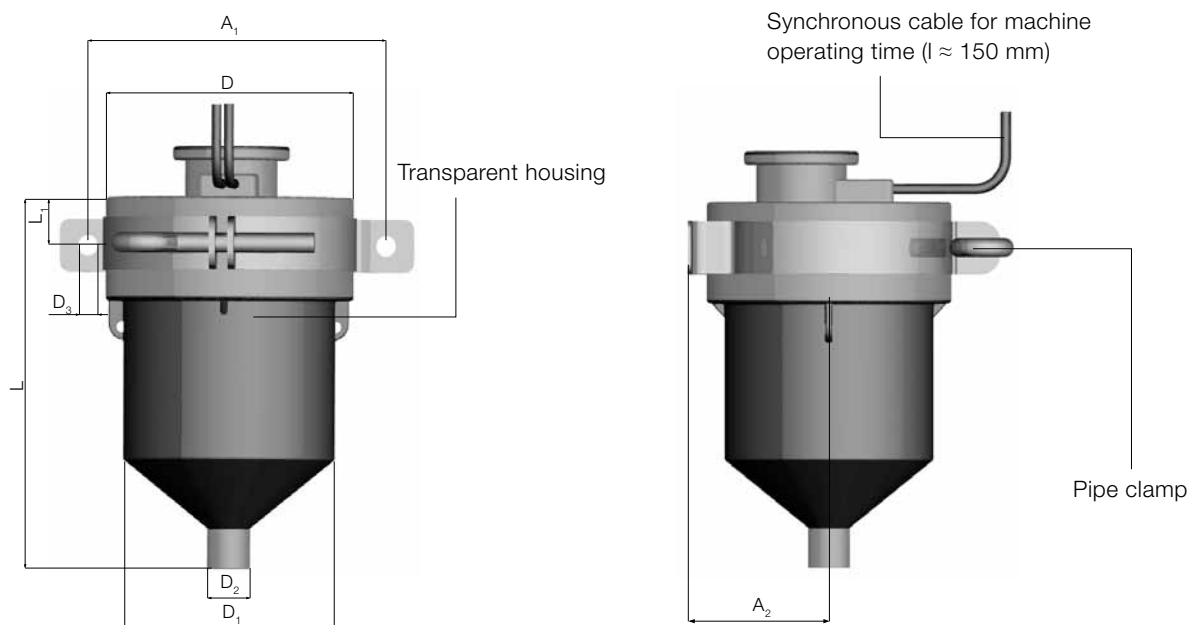

Technical data of lubricator

Lubricator type	125	475
Approx. capacity cm ³	100	460
Connection thread	R ¼"	R ½"
Setting time	1, 2, 3, 6, 12 or 18 months	
Weight	370 g	1000 g
Pressure	0.2 to 3 bar	
Drive	2 x 1.5 V	4 x 1.5 V
Temperature range	10°C to 50°C	
Battery capacity	about 2000 mAh	about 4000 mAh
Battery consumption after 1 year	about 285 mAh	about 800 mAh
Grease filling	Klüber Microlube GB 0	
Accessories	Sensor, replacement lubricator	
Mounting position	Any	

Recommended lubrication

Depending on the conditions of use, it is possible to set the lubricator to various emptying times with a micro switch (1, 2, 3, 6, 12 or 18 months).

Our recommendation for a constant movement speed of 90 m/min: for example, module 2: 0.175 to 0.35 cm³/day or module 3: 0.35 to 0.7 cm³/day

Grease dosing for felt pinion lubrication

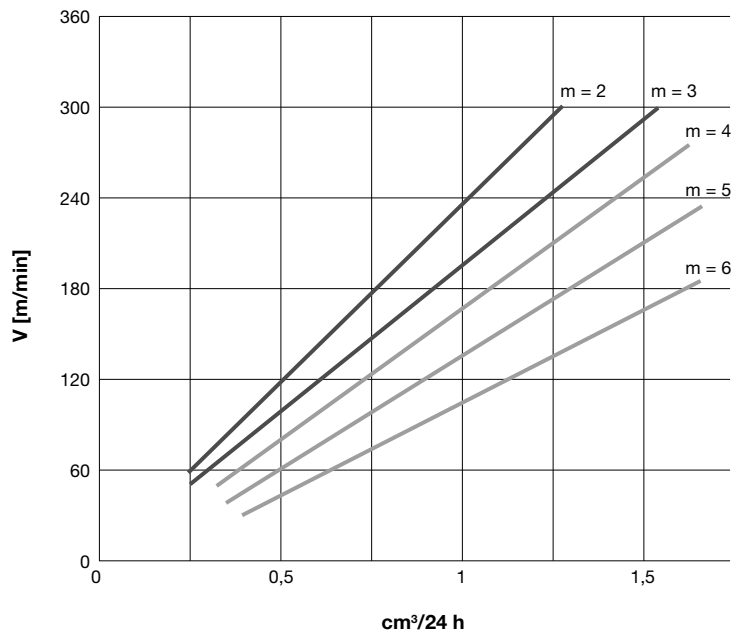

Assembly accessories

You will need an assembly jig to align the transfers between the individual racks. You will also need a needle roller when making a final check with the dial gauge.

Assembly jig

Module	L	z	B	H	h
2	100	14	24	24	22
3	100	9	29	29	26
4	156	8	46	46	41
5	156	7	46	46	41
6	156	7	46	46	40

Needle roller

Module	Order number
2	20001001
3	20000049
4	20038001
5	20038002
6	20038003

Bolts and cylinder pins

(not included in the scope of delivery)

To fasten each rack, you will need bolts and cylinder pins specified in the table below. The length of the bolts and pins depends on the design of the machine bed.

Module	Length	Class			Bolt DIN EN ISO 4762-12.9 (quantity x thread)	Tightening torque		Cylinder pin with inner thread DIN7979 / DIN EN ISO 8735, form A
		Premium	Smart	Value		(Nm)	(in.lb)	
2	1000			x	8 x M6	16.5	(147)	2 x 6 m6
2	500	x			4 x M6	16.5	(147)	2 x 6 m6
2	480		x		8 x M8	40	(354)	2 x 8 m6
2	333	x			4 x M6	16.5	(147)	2 x 6 m6
2	167	x			2 x M6	16.5	(147)	2 x 6 m6
3	1000			x	8 x M8	40	(354)	2 x 8 m6
3	500	x			4 x M8	40	(354)	2 x 8 m6
3	480		x		8 x M10	81	(717)	2 x 10 m6
3	250	x			2 x M8	40	(354)	2 x 8 m6
4	1000			x	8 x M8	40	(354)	2 x 8 m6
4	507	x			4 x M10	81	(717)	2 x 10 m6
4	480		x		8 x M12	140	(1239)	2 x 10 m6
5	1000			x	8 x M12	140	(1239)	2 x 12 m6
5	500	x			4 x M12	140	(1239)	2 x 12 m6
6	1000			x	8 x M16	220	(1947)	2 x 16 m6
6	500	x			4 x M16	220	(1947)	2 x 16 m6





alpha IQ – WITTENSTEIN alpha gearbox with integrated sensors – helping you better understand your processes

alpha IQ

Details



Understanding processes through intelligent sensor gearboxes

– low backlash planetary gearboxes + integrated sensors

Sensor gearboxes allow you to measure, diagnose and assess process parameters directly, i.e. all mechanical loads processed by the gearbox can be measured at the output drive.



Sensor gearbox information

Gearbox

Low backlash planetary gearboxes of renowned WITTENSTEIN alpha quality

Sensors

Intelligent sensor technology integrated in the gearbox

Electronics box

Receives signals from the gearbox and serves as a communication and storage medium

Application areas of the sensor gearbox and customer benefits

Diagnosis

alpha IQ allows you to measure the forces generated in the existing application without modifying the machine design.

This measurement then forms the basis for optimization measures for the drive train design and allows you to select the **right drive system components** and verify calculations to save valuable resources.

Process monitoring

By measuring key parameters, sensor gearboxes provide a revealing insight into previously unknown process mechanisms.

A more accurate understanding of machine processes can be applied directly to **improve process stability**.

Process control

Measurements provide valuable information that can be used to control and optimize your manufacturing process in realtime.

This simple method for **optimizing processes** will impress your customers.

alpha IQ – Measured parameters



Torque



X direction



Y direction



Temperature

Software

Calibration or display and evaluation software

Interfaces

RS232, voltage interface, current interface and field buses via gateway

Gearbox types and sizes

SP+ 075, SP+ 100, SP+ 140
TP+ 010, TP+ 025, TP+ 050



Shrink discs



Shrink disc

Machine shaft installation

A shrink disc is used to fit the mounted shaft to the gearhead. The shrink disc is not included in the gearhead scope of delivery and must be ordered as an accessory (see table).

Gearhead type	Article code			d	D	A	H*	H2*	J [kgcm ²]
	Standard	Chemically nickel plated	Stainless steel						
SP+ 060 SPK+ 060 HG+ 060	20000744	20048496	20048491	18	44	30	15	19	0,393
SP+ 075 SPK+ 075 HG+ 075	20001389	20047957	20043198	24	50	36	18	22	0,753
SP+ 100 SPK+ 100 HG+ 100	20001391	20048497	20035055	36	72	52	22	27,3	3,94
SP+ 140 SPK+ 140 HG+ 140	20001394	20048498	20047937	50	90	68	26	31,3	11,1
SP+ 180 SPK+ 180 HG+ 180	20001396	20048499	20048492	68	115	86	29	35,4	31,1

* in unclamped state

Gearhead type	Article code			d	D	A	H*	H2*	J [kgcm ²]
	Standard	Chemically nickel plated	Stainless steel						
VDH 050	20020687	20047934	20047885	30	60	44	20	24	1,82
VDH 063	20020688	20047530	20035055	36	72	52	22	27,3	3,94
VDH 080	20020689	20047935	20047937	50	90	68	26	31,3	11,1
VDH 100	20020690	20047927	20047860	62	110	80	29	34,3	27

* in unclamped state

One shrink disc per gearhead is sufficient.

Please refer to the operating instructions for information on correct shrink disc installation. The instructions are enclosed with the order.

Recommendation for the load shaft:

Tolerance h6

Surface roughness $\leq R_z 10$

Minimum yield strength $R_p 0,2 \geq 360 \text{ N/mm}^2$

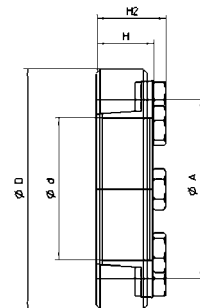

Backlash-free elastomer couplings

Features:

- vibration damping
- electrically insulating (standard)
- backlash-free
- press-fit design
- compensation for lateral-, angular- and axial misalignment

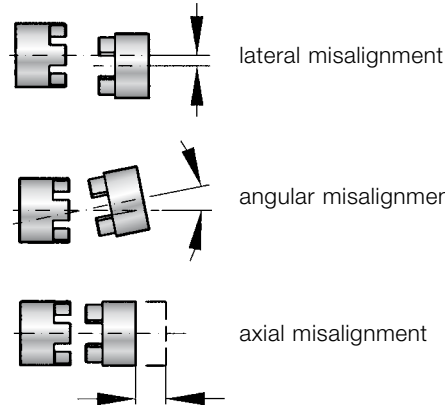

Function elastomer insert

The equalizing element of an EK coupling is the elastomer insert. It transmits the torque without backlash and vibration. The elastomer insert defines the features of the entire coupling and/or of the entire drive system.

The coupling is backlash free due to pretensioning of the elastomer insert between the two coupling halves. The alpha-Coupling compensates for lateral, angular and axial misalignment.



Type A
Shore hardness 98 Sh A



Type B
Shore hardness 64 Sh D



Type C
Shore hardness 80 Sh A

Specification of the elastomer inserts

Type	Shore hardness	Color	Material	Relative damping (ψ)	Temperature range	Features
A	98 Sh A	red	TPU	0.4-0.5	-30°C to +100°C	high damping
B	64 Sh D	green	TPU	0.3-0.45	-30°C to +120°C	high torsional stiffness
C	80 Sh A	yellow	TPU	0.3-0.4	-30°C to +100°C	very high damping

The values of the relative damping were determined at 10 Hz and +20°C.

Model row EL		Series																										
		2			5			10			20			60			150			300			450			800		
Type (elastomer insert)		A	B	C	A	B	C	A	B	C	A	B	C	A	B	C	A	B	C	A	B	C	A	B	C	A	B	C
Static torsional stiffness	C_T Nm/rad	50	115	17	150	350	53	260	600	90	1140	2500	520	3290	9750	1400	4970	10600	1130	12400	18000	1280	15100	27000	4120	41300	66080	10320
Dynamic torsional stiffness	C_{Tdyn} Nm/rad	100	230	35	300	700	106	541	1650	224	2540	4440	876	7940	11900	1350	13400	29300	3590	23700	40400	6090	55400	81200	11600	82600	180150	28600
Lateral	Max. values mm	0,08	0,06	0,1	0,08	0,06	0,1	0,1	0,08	0,12	0,1	0,08	0,15	0,12	0,1	0,15	0,15	0,12	0,2	0,18	0,14	0,25	0,2	0,18	0,25	0,25	0,2	0,3
Angular	Max. values degree	1	0,8	1,2	1	0,8	1,2	1	0,8	1,2	1	0,8	1,2	1	0,8	1,2	1	0,8	1,2	1	0,8	1,2	1	0,8	1,2	1	0,8	1,2
Axial	Max. values mm	±1			±1			±1			±2			±2			±2			±2			±2			±2		

Static torsional stiffness at 50% $T_{0,5}$

Dynamic torsional stiffness at $T_{0,5}$

ELC – Elastomer Couplings

Model ELC			Series																										
			2			5			10			20			60			150			300			450			800		
Type (Elastomer insert)			A	B	C	A	B	C	A	B	C	A	B	C	A	B	C	A	B	C	A	B	C	A	B	C	A	B	C
Rated torque	T_{KN}	Nm	2	2,4	0,5	9	12	2	12,5	16	4	17	21	6	60	75	20	160	200	42	325	405	84	530	660	95	950	1100	240
Max. torque**	T_{Kmax}	Nm	4	4,8	1	18	24	4	25	32	6	34	42	12	120	150	35	320	400	85	650	810	170	1060	1350	190	1900	2150	400
Overall length	A	mm	20			26			32			50			58			62			86			94			123		
Outer diameter	B	mm	16			25			32			42			56			66,5			82			102			136,5		
Outer diameter with screwhead	B_s	mm	17			25			32			44,5			57			68			85			105			139		
Mounting length	C	mm	6			8			10,3			17			20			21			31			34			46		
Inner diameter range H7	$D_{1/2}$	mm	3 bis 8			4 bis 12,7			4 bis 16			8 bis 25			12 bis 32			19 bis 36			20 bis 45			28 bis 60			35 bis 80		
Inner diameter max. (elastomer)	D_E	mm	6,2			10,2			14,2			19,2			26,2			29,2			36,2			46,2			60,5		
Mounting Screw (ISO 4762/12.9)	E		M2			M3			M4			M5			M6			M8			M10			M12			M16		
Tightening torque of the mounting screw		Nm	0,6			2			4			8			15			35			70			120			290		
Distance between centers	F	mm	5,5			8			10,5			15,5			21			24			29			38			50,5		
Distance	G	mm	3			4			5			8,5			10			11			15			17,5			23		
Hub length	H	mm	12			16,7			20,7			31			36			39			52			57			74		
Moment of inertia per Hub	$J1/J2 \cdot 10^{-3} \text{ kgm}^2$		0,0003			0,002			0,003			0,01			0,04			0,08			0,3			0,66			8		
Approx. weight		kg	0,008			0,02			0,05			0,12			0,3			0,5			0,9			1,5			8,5		
Speed*		rpm	28000			22000			20000			19000			14000			11500			9500			8000			4000		

Information about static and dynamic torsional stiffness as well as max. possible misalignment see page 329.
 ** Maximum transferable torque of the clamping hub depends on the bore diameters

Series	Ø 3	Ø 4	Ø 5	Ø 8	Ø 16	Ø 19	Ø 25	Ø 30	Ø 32	Ø 35	Ø 45	Ø 50	Ø 55	Ø 60	Ø 65	Ø 70	Ø 75	Ø 80
2	0,2	0,8	1,5	2,5														
5		1,5	2	8														
10			4	12	32													
20				20	35	45	60											
60					50	80	100	110	120									
150						120	160	180	200	220								
300						200	230	300	350	380	420							
450								420	480	510	600	660	750	850				
800									700	750	800	835	865	900	925	950	1000	

Higher torque through additional key possible.

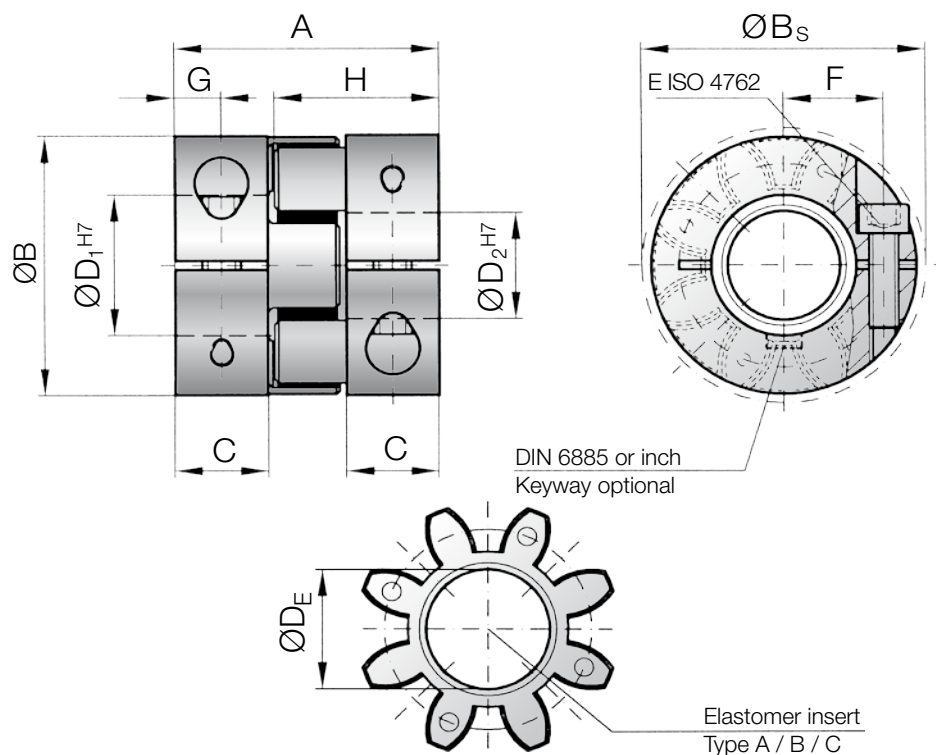

Properties:

- short compact design
- easy assembly
- vibration damping
- electrically insulating
- backlash-free
- press-fit design

Material:

Clamping hub: up to series 450 high strength aluminum, from series 800 and up steel

Elastomer insert: precision molded, wear resistant, and thermally stable polymer

Design:

Two coupling hubs are concentrically machined with concave driving jaws

*Speeds:

Over 4,000 rpm a finely balanced version is available

Tolerance:

On the hub/shaft connection 0.01 to 0.05 mm



EL6 – Elastomer Couplings

Model EL6			Series																				
			10			20			60			150			300			450			800		
Type (Elastomer insert)			A	B	C	A	B	C	A	B	C	A	B	C	A	B	C	A	B	C	A	B	C
Rated torque	T_{KN}	Nm	12,6	16	4	17	21	6	60	75	20	160	200	42	325	405	84	530	660	95	950	1100	240
Max. torque	T_{Kmax}	Nm	25	32	6	34	42	12	120	150	35	320	400	85	650	810	170	1060	1350	190	1900	2150	400
Overall length	A	mm	42			56			64			76			96			110			138		
Outer diameter	B	mm	32			43			56			66			82			102			136,5		
Mounting length	C	mm	15			20			23			28			36			42			53		
Inner diameter range H7	$D_{1/2}$	mm	6 bis 16			8 bis 24			12 bis 32			19 bis 35			20 bis 45			28 bis 55			32 bis 80		
Inner diameter max. (elastomer)	D_E	mm	14,2			19,2			26,2			29,2			36,2			46,2			60,5		
Mounting screw (ISO 4762/12.9)	E	Nm	3x M3			6x M4			4x M5			8x M5			8x M6			8x M8			8x M10		
Tightening torque of the mounting screw			2			3			6			7			12			35			55		
Width Elastomer insert	F	mm	9,5			12			14			15			18			20			25		
Moment of inertia per Hub	J1/J2	10^{-3} kgm^2	0,004			0,015			0,05			0,1			0,3			0,85			9,2		
Approx. weight		kg	0,08			0,12			0,3			0,5			0,9			1,5			9,6		
Speed		rpm	20000			19000			14000			11500			9500			8000			4000		

Information about static and dynamic torsional stiffness as well as max. possible misalignment see page 329.

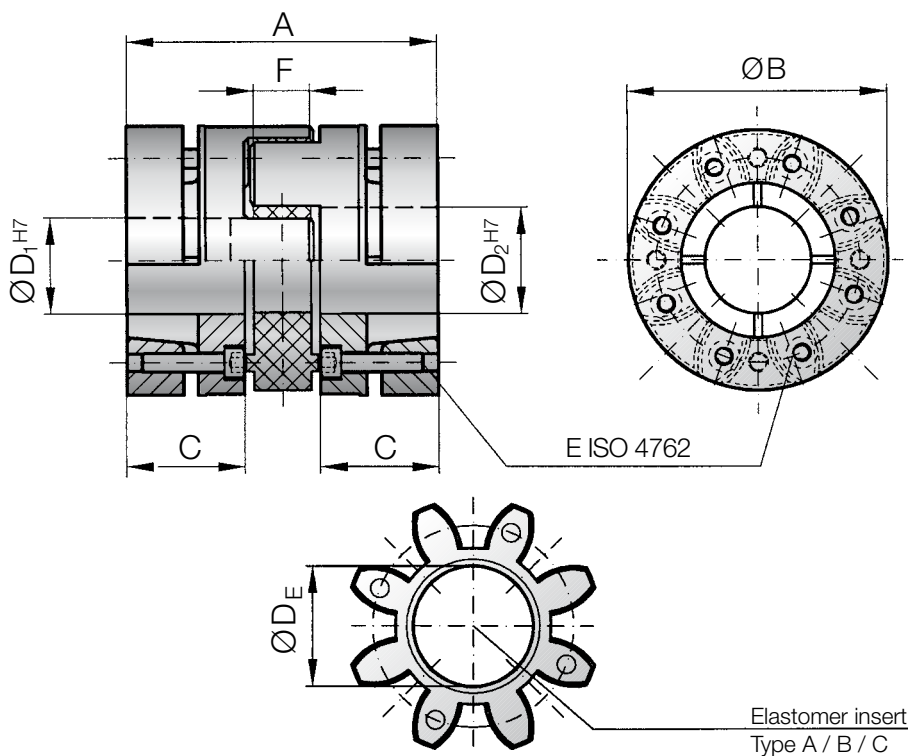

Properties:

- high clamping forces
- concentrically machined
- easy mounting
- damps vibrations
- electrical insulating
- backlash-free
- press-fit design
- axial mounting possible

Material:

Clamping hub and conical clamping: up to series 450 high strength aluminum, from series 800 and up steel
 Elastomer insert: precision molded, wear resistant, and thermally stable polymer

Design:

Two coupling hubs are concentrically machined with concave driving jaws

Tolerance:

On the hub/shaft connection 0.01 to 0.05 mm



TL – Torque limiters

Safe torque limitation

Single position re-engagement – standard version

After the overload has been removed, the torque limiter can be re-engaged precisely 360 degrees from the original disengagement position.

A proven principle that guarantees synchronism. Signal in the event of an overload. Suitable for use in machine tools, packaging machines and automation systems.



Load holding version

In the event of an overload, the drive and the drive elements are not separated or are only allowed limited rotation. Guaranteed load safety. Automatic engagement of the torque limiter after the torque level has dropped. Signal in the event of an overload. Suitable for use on presses or load-lifting equipment.

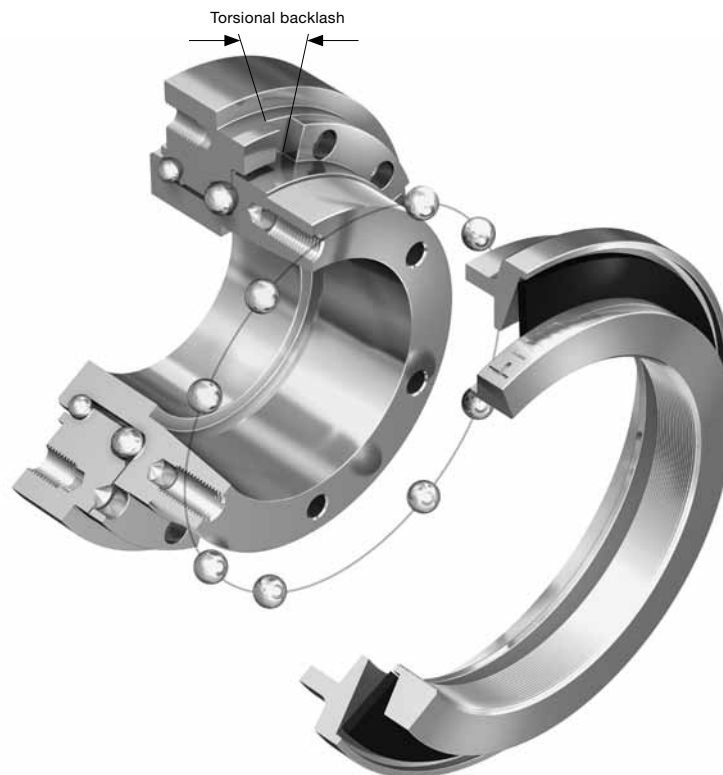

Multi-position version

Coupling re-engages automatically at the very next ball detent. The coupling is immediately ready for operation again at several points after an overload. Immediate availability of the machine or plant as soon as the overload has been removed. Signal in the event of an overload. Standard engagement after 60 degrees. Optional engagement after 30, 45, 60, 90 and 120 degrees.

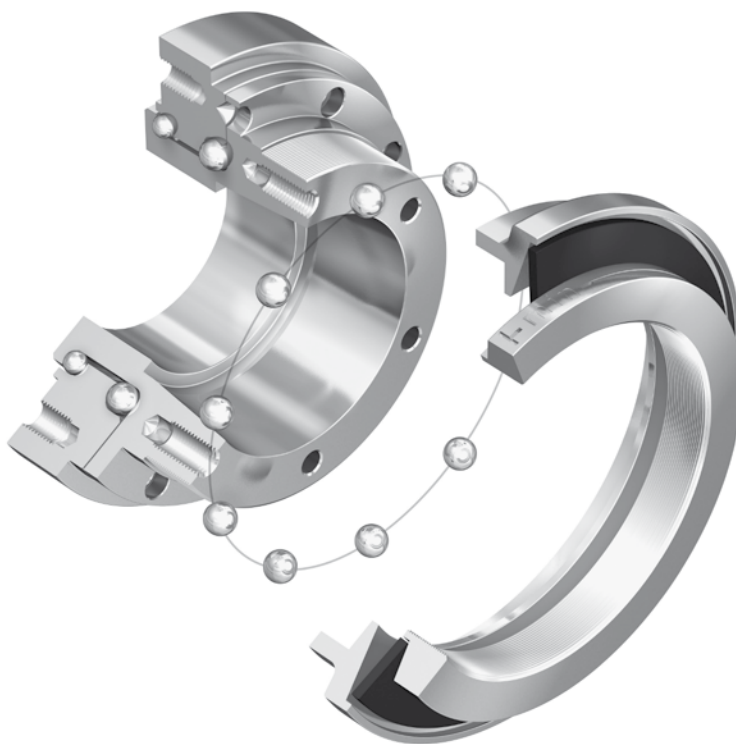

Full disengagement version

Permanent separation of the drive and the drive elements in the event of an overload. Spring flips over completely. No residual friction. Torque limiter can be re-engaged manually (re-engagement possible every 60 degrees).

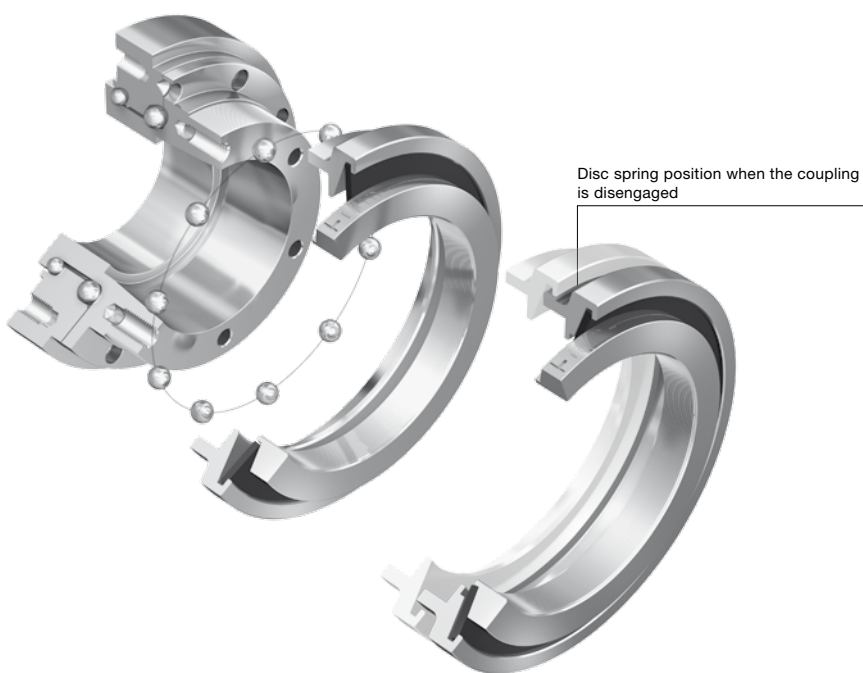

TL1 – Torque limiter

			Series															
			Miniature design series															
			1.5	2	4.5	10	15	30	60	150	200	300	500	800	1500	2500		
Adjustment range from – to (approx. values)	T_{KV}	A	Nm	0.1–0.6	0.2–1.5	1–3	2–6	5–15	5–20	10–30	20–70	30–90	100–200	80–200	400–650	600–800	1500–2000	
			in.lb	1–6	2–14	9–27	18–54	45–133	45–177	89–266	177–620	266–797	885–1770	708–1770	3540–5753	5310–7080	13275–17700	
		B	Nm	0.4–1	0.5–2.2	2–4.5	4–12	12–25	10–30	25–80	45–150	60–160	150–240	200–350	500–800	700–1200	2000–2500	
			in.lb	4–9	5–20	18–40	36–107	107–222	89–266	222–708	399–1328	531–1416	1328–2124	1770–3098	4425–7080	6195–10620	17700–22125	
		C	Nm	0.8–2	1.5–3.5	3–7	7–18	20–40	20–60	50–115	80–225	140–280	220–440	320–650	650–950	1000–1800	2300–2800	
			in.lb	8–18	14–31	27–62	62–160	177–354	177–531	443–1018	708–1992	1239–2478	1947–3894	2832–5753	5753–8408	8850–15930	20355–24780	
		D	Nm	–	–	–	–	35–70	50–100	–	–	250–400	–	–	–	–	–	
			in.lb	–	–	–	–	310–620	443–885	–	–	222–3540	–	–	–	–	–	
Adjustment range from – to (approx. values), full disengagement	T_{KV}	A	Nm	0.3–0.8	0.5–2	2.5–4.5	2–5	7–15	8–20	10–30	20–60	80–140	120–180	50–150	200–400	1000–1250	1400–2200	
			in.lb	3–8	5–18	23–40	18–45	62–133	71–177	89–266	177–531	708–1239	1062–1593	443–1328	1770–3540	8850–11063	12390–19470	
		B	Nm	0.6–1.3	–	–	4–10	–	16–30	20–40	40–80	130–200	160–300	100–300	450–850	1250–1500	1800–2700	
			in.lb	6–12	–	–	36–89	–	142–266	177–354	354–708	1151–1770	1416–2655	885–2655	3983–7523	11063–13275	15930–23895	
		C	Nm	–	–	–	8–15	–	–	30–60	80–150	–	–	250–500	–	–		
			in.lb	–	–	–	71–133	–	–	266–531	708–1328	–	–	2213–4425	–	–		
		Overall length	A	mm	23	28	32	39	40	50	54	58	63	70	84	95	109	146
		Overall length, full disengagement	A ^F	mm	23	28	32	39	40	50	54	58	66	73	88	95	117	152
Outer diameter of actuation ring	B	mm	23	29	35	45	55	65	73	92	99	120	135	152	174	242		
Actuation ring Ø, full disengagement	B ^F	mm	24	32	42	51.5	62	70	83	98	117	132	155	177	187	258		
Clamping fit length	C	mm	7	8	11	11	19	22	27.5	32	32	41	41	49	61	80		
Inner diameter from Ø to Ø H7	D	mm	4–8	4–12	5–14	6–20	8–22	12–22	12–29	15–37	20–44	25–56	25–56	30–60	35–70	50–100		
Centering diameter h7	E	mm	14	22	25	34	40	47	55	68	75	82	90	100	125	168		
Hole circle diameter ±0.2	F	mm	22	28	35	43	47	54	63	78	85	98	110	120	148	202		
Flange diameter – 0.2	G	mm	26	32	40	50	53	63	72	87	98	112	128	140	165	240		
Thread	H		4xM2	4xM2.5	6xM2.5	6xM3	6xM4	6xM5	6xM5	6xM6	6xM6	6xM8	6xM8	6xM10	6xM12	6xM16		
Thread length	I	mm	3	4	4	5	6	8	9	10	10	10	12	15	16	24		
Centering length – 0.2	J	mm	2.5	3.5	5	8	3	5	5	5	5	6	9	10	13.5	20		
Distance	K	mm	5	6	8	11	8	11	11	12	12	15	21	19	25	34		
Distance	L	mm	11	15	17	22	27	35	37	39	44	47	59	67	82	112		
Distance, full disengagement	L ^F	mm	11.5	16	18	24	27	37	39	41.5	47	51.5	62	75	91	120		
Distance	M		2.5	4	4	5	–	–	–	–	–	–	–	–	–	–		
Screws to ISO 4762	N		M2.5	M3	M4	M4	M4	M5	M5	M6	M6	M8	M8	M10	M12	M16		
Tightening torque	N	Nm	1	2	4	4.5	4	6	8	12	14	18	25	40	70	120		
		in.lb	9	18	36	40	36	54	71	107	124	160	222	354	620	1062		
Outer diameter of clamping ring	O ₁	mm	20	25	32	40	–	–	–	–	–	–	–	–	–	–		
Diameter	O ₂	mm	13	18	21	30	35	42	49	62	67	75	84	91	112	154		
Diameter h7	O ₃	mm	11	14	17	24	27	32	39	50	55	65	72	75	92	128		
Distance between centers	P	mm	6.5	8	10	15	–	–	–	–	–	–	–	–	–	–		
Distance	R	mm	1	1.3	1.5	1.5	2.5	2.5	2.5	2.5	3	3	4	4	4.5	6		
Moment of inertia	J	10 ³ kgm ²	0.01	0.02	0.05	0.07	0.15	0.25	0.50	1.60	2.70	5.20	8.60	20	31.5	210		
		in.lb.s ² .10 ³	0.0089	0.0177	0.0443	0.0620	0.1328	0.2213	0.4425	1.4161	2.3897	4.6024	7.6116	17.7014	27.8797	185.86		
Approx. weight		kg	0.03	0.065	0.12	0.22	0.4	0.7	1.0	1.3	2.0	3.0	4.0	5.5	10	28		
		lb	0.066	0.143	0.265	0.485	0.882	1.543	2.205	2.866	4.409	6.614	8.818	12.125	22.046	61.729		
Actuation path		mm	0.7	0.8	0.8	1.2	1.5	1.5	1.7	1.9	2.2	2.2	2.2	2.2	3.0	3.0		

A^F, B^F, L^F = Full disengagement version

Torque limiter TL1 (1.5–10)
With clamping hub

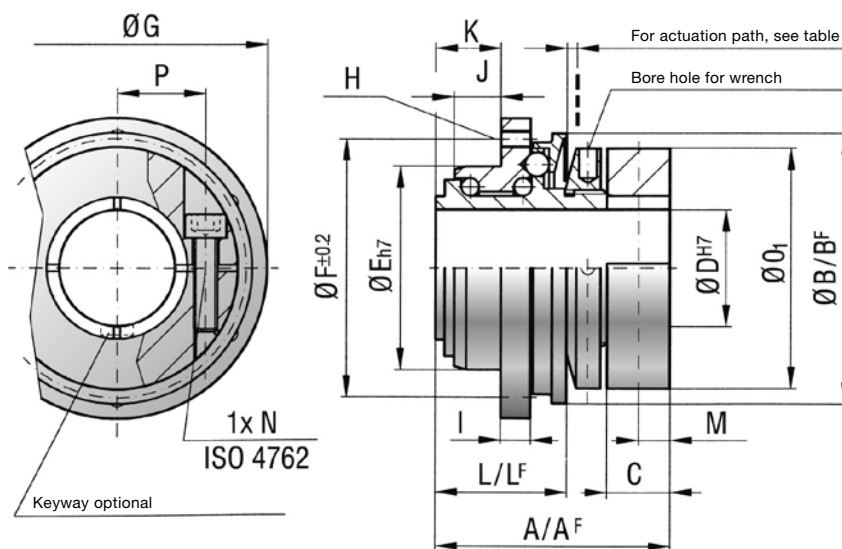

Torque limiter TL1 (15–2500)
With conical clamping hub

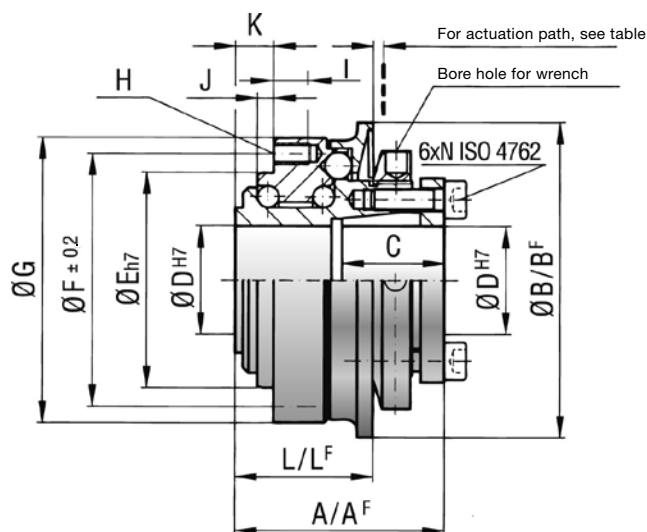

Torque limiter for timing belt and sprocket applications

Material:

High-strength, hardened steel.

Design:

Model TL1: 1.5–10 Nm (13.3 – 88.5 in.lb)
with split clamping hub.

Model TL1: 15–2500 Nm (132.8 – 22125 in.lb)
with conical clamping hub.

Temperature range: -30 °C to +120°C (-22 °F to 248°F)

Temperature peaks: up to +150°C (302°F)

Backlash:

Completely backlash-free as a result of the
frictional clamp connection and patented preload.

Service life:

These torque limiters are permanent and
maintenance-free as long as the performance limits are not
exceeded.

Fit tolerance: Tolerance between shaft and hub 0.01–0.05 mm

TL2 – Torque limiter

			Series																													
			1.5		2		4.5		10		15		30		60		80		150		200		300		500		800		1500			
Length options (see ordering code)			A		A B		A B		A B		A B		A B		A B		A B		A B		A B		A B		A		A					
Adjustment range from – to (approx. values)	T_{KN}	Nm	A		0.1–0.6		0.2–1.5		1–3		2–6		5–10		10–25		10–30		20–70		20–70		30–90		100–200		80–200		400–650		650–800	
			in.lb		1-6		2-14		9-27		18-54		45-89		89-222		89-266		177-620		177-620		266-797		885-1770		708-1770		3540-5753		5753-7080	
		Nm	B		0.4–1		0.5–2		3–6		4–12		8–20		20–40		25–28		30–90		45–150		60–160		150–240		200–350		500–800		700–1200	
			in.lb		4-9		5-18		27-54		36-107		71-177		177-354		222-248		266-797		399-1328		531-1416		1328-2124		1770-3098		4425-7080		6195-10620	
		Nm	C		0.8–1.5		–		–		–		–		–		–		–		80–180		120–240		200–320		300–500		650–850		1000–1800	
			in.lb		8-14		–		–		–		–		–		–		–		708-1593		1062-2124		1770-2832		2655-4425		5753-7523		8850-15930	
Adjustment range from – to (approx. values), full disengagement	T_{KN}	Nm	A		0.3–0.8		0.5–2		2.5–4.5		2–5		7–15		8–20		20–40		20–60		20–60		80–140		120–180		60–150		200–400		1000–1250	
			in.lb		3-8		5-18		23-40		18-45		62-133		71-177		177-354		177-531		177-531		708-1239		1062-1593		531-1328		1770-3540		8850-11063	
		Nm	B		0.6–1.3		–		–		5–10		–		16–30		30–60		40–80		40–80		130–200		180–300		100–300		450–800		1250–1500	
			in.lb		6-12		–		–		45-89		–		142-266		266-531		354-708		354-708		1151-1770		1593-2655		885-2655		3983-7080		11063-13275	
		Nm	C		–		–		–		–		–		–		–		–		80–150		–		–		250–500		–		–	
			in.lb		–		–		–		–		–		–		–		–		708-1328		–		–		2213-4425		–		–	
Overall length	A	mm	42	46	51	57	65	65	74	75	82	87	95	102	112	115	127	116	128	128	140	139	153	163	177	190	223					
Overall length, full disengagement	A ^F	mm	42	46	51	57	65	65	74	75	82	87	95	102	112	117	129	118	130	131	143	142	156	167	181	201	232					
Actuation ring Ø	B	mm	23	29	35	45	55	65	73	92	92	99	120	135	152	174																
Actuation ring Ø, full disengagement	B ^F	mm	24	32	42	51.5	62	70	83	98	98	117	132	155	177	187																
Fit length	C	mm	11	13	16	16	22	27	31	35	35	40	42	51	48	67																
Inner diameter from Ø to Ø H7	D ₁ /D ₂	mm	3–8	4–12	5–14	6–20	10–26	12–30	15–32	19–42	19–42	24–45	30–60	35–60	40–75	50–80																
Outer diameter of coupling	E	mm	19	25	32	40	49	55	66	81	81	90	110	123	134	157																
Distance	F	mm	12	13	15	17	19	24	30	31	31	35	35	45	50	65																
Distance, full disengagement	F ^F	mm	11.5	12	14	16	19	22	29	31	30	33	35	43	54	61																
Distance	G	mm	3.5	4	5	5	6.5	7.5	9.5	11	11	12.5	13	17	18	22.5																
Distance between centers	H	mm	6	8	10	15	17	19	23	27	27	31	39	41	2x48	2x55																
Screws to ISO 4762	I		M2.5	M3	M4	M4	M5	M6	M8	M10	M10	M12	M12	M16	2xM16	2xM20																
Tightening torque	I	Nm	1	2	4	4.5	8	15	40	50	70	120	130	200	250	470																
		in.lb	9	18	36	40	71	133	354	443	620	1062	1151	1770	2213	4160																
Approx. weight		kg	0.035	0.07	0.2	0.3	0.4	0.6	1.0	2.0	2.4	4.0	5.9	9.6	14	21																
		lb	0.08	0.15	0.44	0.66	0.88	1.32	2.21	4.41	5.30	8.82	13.1	21.2	30.9	46.3																
Moment of inertia	J	10 ⁻³ kgm ²	0.01	0.01	0.01	0.02	0.02	0.06	0.07	0.10	0.15	0.27	0.32	0.75	0.80	1.80	1.90	2.50	2.80	5.10	5.30	11.5	11.8	22.8	23.0	42.0	83.0					
		10 ⁻³ in.lb.s ²	0.0089	0.0089	0.0089	0.0177	0.0177	0.0531	0.0620	0.0885	0.1328	0.2390	0.2832	0.6638	0.7081	1.59	1.68	2.21	2.48	45.1	46.9	10.2	10.4	20.2	20.4	37.2	73.5					
Torsional rigidity	C _T	10 ⁻³ Nm/rad	0.7	1.2	1.3	7	5	9	8	20	15	39	28	76	55	129	85	175	110	191	140	420	350	510	500	780	1304					
Lateral misalignment		mm	0.15	0.15	0.20	0.20	0.25	0.20	0.30	0.15	0.20	0.20	0.25	0.20	0.25	0.20	0.25	0.20	0.25	0.25	0.30	0.25	0.30	0.30	0.35	0.35	0.35					
Angular misalignment		degrees	1	1	1.5	1.5	2	1.5	2	1	1.5	1	1.5	1	1.5	1	1.5	1	1.5	1.5	2	1.5	2	2	2.5	2.5	2.5					
Lateral spring stiffness		N/mm	70	40	30	290	45	280	145	475	137	900	270	1200	420	920	255	1550	435	2040	610	3750	1050	2500	840	2000	3600					
Actuation path		mm	0.7	0.8	0.8	1.2	1.5	1.5	1.7	1.9	1.9	2.2	2.2	2.2	3.0																	

A^F, B^F, L^F = Full disengagement version
Smaller sizes on request

Torque limiter TL2

With clamping hub

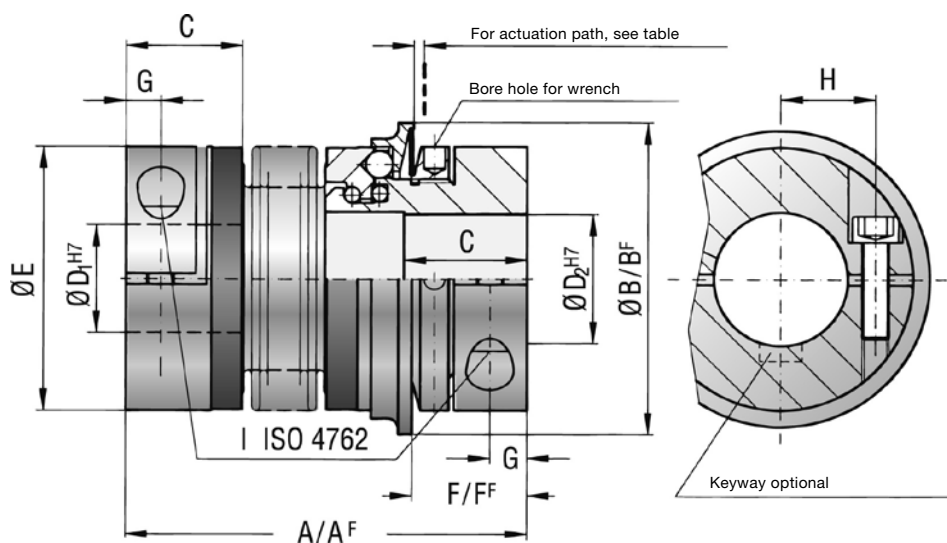

Torque limiter for direct drives

Material:

Bellows made of highly flexible stainless steel. Safety section made of high-strength, hardened steel. Clamping hub material: up to series 80 aluminum and from series 150 steel.

Design:

With clamping hubs and a single lateral screw to ISO 4762.

Temperature range: -30 °C to +120°C (-22 °F to 248 °F)

Backlash:

Completely backlash-free as a result of the frictional clamp connection and patented preload.

Service life:

These torque limiters are permanent and maintenance-free as long as the performance limits are not exceeded.

Fit tolerance: Tolerance between shaft and hub 0.01 – 0.05 mm

TL3 – Torque limiter

			Series																			
			15		30		60		150		200		300		500		800		1500	2500		
Length options (see ordering code)			A	B	A	B	A	B	A	B	A	B	A	B	A	B	A	A				
Adjustment range from – to (approx. values)	T_{KN}	Nm	5–10		10–25		10–30		20–70		30–90		100–200		80–200		400–650		650–850		1500–2000	
		in.lb	45–89		89–222		89–266		177–620		266–797		885–1770		708–1770		3540–5753		5753–7523		13275–17700	
		Nm	8–20		20–40		25–80		45–150		60–160		150–240		200–350		500–800		700–1200		2000–2500	
		in.lb	71–177		177–354		222–708		399–1328		531–1416		1328–2124		1770–3098		4425–7080		6195–10620		17700–22125	
		Nm	–		–		–		80–200		140–280		220–400		300–500		600–900		1000–1800		2300–2800	
		in.lb	–		–		–		708–1770		1239–2478		1947–3540		2655–4425		5310–7965		8850–15930		20355–24780	
Adjustment range from to (approx. values), full engagement	T_{KN}	Nm	7–15		8–20		20–40		20–60		80–140		120–180		60–150		200–400		1000–1250		1400–2200	
		in.lb	62–133		71–177		177–354		177–531		708–1239		1062–1593		531–1328		1770–3540		8850–11063		12390–19470	
		Nm	–		16–30		30–60		40–80		130–200		180–300		100–300		450–800		1250–1500		1800–2700	
		in.lb	–		142–266		266–531		354–708		1151–1770		1593–2655		885–2655		3983–7080		11063–13275		15930–23895	
		Nm	–		–		–		80–150		–		–		250–500		–		–		–	
		in.lb	–		–		–		708–1328		–		–		2213–4425		–		–		–	
Overall length	A	mm	62	69	72	80	84	94	93	105	99	111	114	128	123	136	151	175	246			
Overall length, full disengagement	A ^F	mm	62	69	72	80	84	94	93	105	102	114	117	131	127	140	151	184	252			
Actuation ring Ø	B	mm	55		65		73		92		99		120		135		152	174	243			
Actuation ring Ø, full disengagement	B ^F	mm	62		70		83		98		117		132		155		177	187	258			
Fit length	C	mm	19		22		27		32		32		41		41		49	61	80			
Inner diameter from Ø to Ø H7	D ₁ /D ₂	mm	10–22		12–23		12–29		15–37		20–44		25–56		25–60		30–60	35–70	50–100			
Outer diameter of coupling	E	mm	49		55		66		81		90		110		123		133	157	200			
Distance	F	mm	13		16		18		19		19		23		25		31	30	34			
Distance, full disengagement	F ^F	mm	13		14		17		18		17		20		22		20	26	31			
6xscrews to ISO 4017	I		M4		M5		M5		M6		M6		M8		M8		M10	M12	M16			
Tightening torque	I	Nm	4		6		8		12		14		18		25		40	70	120			
		in.lb	36		54		71		107		124		160		222		354	620	1062			
Approx. weight		kg	0.3		0.4		1.2		2.3		3.0		5.0		6.5		9.0	16.3	35			
		lb	0.66		0.88		2.65		5.07		6.61		11.0		14.3		19.8	35.9	77.2			
Moment of inertia	J	10 ⁻³ kgm ²	0.10	0.15	0.28	0.30	0.75	0.80	1.90	2.00	2.80	3.00	5.50	6.00	11.0	12.8	20.00	42.00	257			
		10 ⁻³ in.lb.s ²	0.0885	0.1328	0.2478	0.2655	0.6638	0.7081	1.68	1.77	2.48	2.66	4.87	5.31	9.74	11.3	17.7	37.2	227.5			
Torsional rigidity	C _T	10 ³ Nm/rad	20	15	39	28	76	55	175	110	191	140	420	350	510	500	780	1304	3400			
Lateral misalignment		mm	0.15	0.20	0.20	0.25	0.20	0.25	0.20	0.25	0.25	0.30	0.25	0.30	0.30	0.35	0.35	0.35	0.35			
Angular misalignment		degrees	1	1.5	1	1.5	1	1.5	1	1.5	1.5	2	1.5	2	2	2.5	2.5	2.5	2.5			
Lateral spring stiffness		N/mm	475	137	900	270	1200	380	1550	435	2040	610	3750	1050	2500	840	2000	3600	6070			
Actuation path		mm	1.5		1.5		1.7		1.9		2.2		2.2		2.2		2.2	3	3			

A^F, B^F, F^F = Full disengagement version

Torque limiter TL3

With conical clamp connection

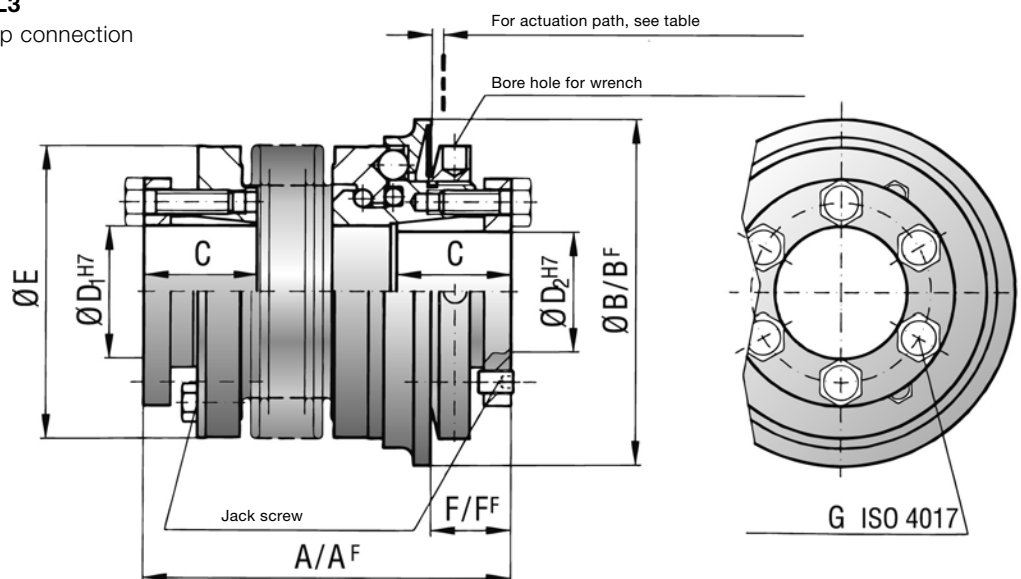

Torque limiter for direct drives

Material:

Bellows made of highly flexible stainless steel. Safety section made of high-strength, hardened steel. Hub material: steel.

Design:

With split conical clamping hubs and captive jack screws.

Temperature range: -30 °C to +120°C (-22 °F to 248 °F)

Backlash:



Completely backlash-free as a result of the frictional clamp connection and patented preload.

Service life:

These torque limiters are permanent and maintenance-free as long as the performance limits are not exceeded.

Fit tolerance: Tolerance between shaft and hub 0.01 – 0.05 mm

BCT – Bellows coupling

		Series				
		15	60	150	300	1500
Gearhead output type		TP-004	TP-010	TP-025	TP-050	TP-110
Centering diameter	D_2 mm	40 h7	63 h7	80 h7	100 h7	160 h7
TP flange hole circle diameter / thread	D_3 mm	31.5 8 x M5	50 8 x M6	63 12 x M6	80 12 x M8	125 12 x M10
Nominal torque	T_{KN} Nm in.lb	40	140	220	400	1570
		354	1239	1947	3540	13895
Length 2	A_1 mm	49	67	72	90	140
Length installation space 2	A_2 mm	68	97	101	128	190
Hub diameter	B_1 mm	49	66	82	110	157
Flange diameter	B_2 mm	63.5	86.5	108	132	188
Fit length	C_1 mm	16.5	23	27.5	34	55
Possible inner diameter from \varnothing to \varnothing H7	D_1 mm	12 - 28	14 - 35	19 - 42	24 - 60	50 - 80
Hole circle diameter / Thread	DL mm	56.5 10 x M4	76 10 x M5	97 10 x M6	120 12 x M6	170 16 x M8
Screws to ISO 4762	E	1 x M5	1 x M8	1 x M10	1 x M12	2 x M20
Tightening torque of fastening screw	E Nm in.lb	8	45	80	120	470
		71	399	708	1062	4160
Distance	G mm	6.5	9.5	11	13	22.5
Approx. weight	I kg lb	0.3	0.7	1	2.8	10
		0.67	1.55	2.21	6.18	22.05
Torsional rigidity	C_T 10^3 Nm/rad 10^3 lb/rad	23	72	141	536	1304
		204	637	1248	4744	11540
Moment of inertia	J 10^{-3} kgm ² 10^{-3} in.lb.s ²	0.15	0.65	1.3	5.5	45
		0.14	0.58	1.16	4.87	39.83
Axial misalignment 	Max. values mm	1	1.5	2	2.5	3
Lateral misalignment 	Max. values mm	0.25	0.25	0.25	0.25	0.2

Max. angular misalignment 1°



Low backlash metal bellows coupling BCT

With flange connection

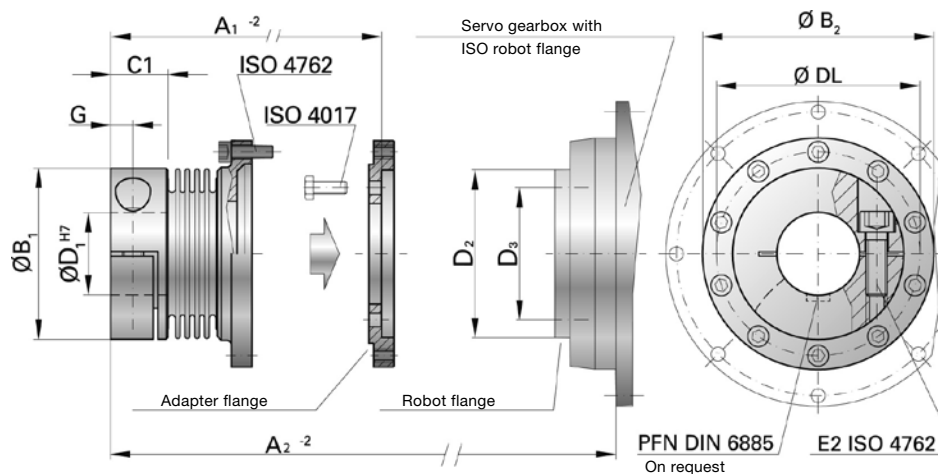

Installation and removal

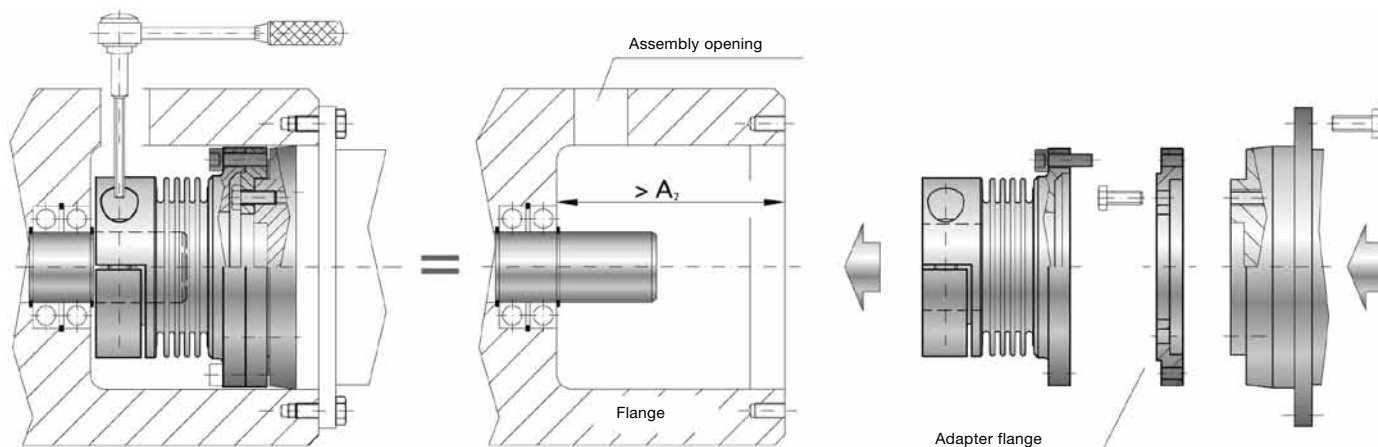

Bellows coupling for direct drives

Material:

Hub: Series 15-150 high-strength alu,
 Series: 300-1500 steel,
 Bellows: High-strength stainless steel,
 Adapter flange: Steel

Design:

Load side: With clamping hubs and a single lateral screw to ISO 4762.
 Gearbox side: With flange connection and separate adapter flange.

Temperature range: -30 °C to +120°C, (-22 °F to 248°F)

Fit tolerance: Tolerance between shaft and hub 0.01–0.05 mm



Speeds:

Up to 10000 rpm

Non-standard applications:

Custom designs with different tolerances, keyways, non-standard material, bellows are available at short notice.

BC2 – Bellows coupling

			Series																	
			15		30		60		80		150		200		300		500		800	1500
Length options (see ordering code)			A	B	A	B	A	B	A	B	A	B	A	B	A	B	A	B	A	A
Rated torque	T_{KN}	Nm	15		30		60		80		150		200		300		500		800	1500
		in.lb	133		266		531		708		1328		1770		2655		4425		7080	13275
Overall length	A	mm	59	66	69	77	83	93	94	106	95	107	105	117	111	125	133	146	140	166
Outer diameter	B	mm	49		55		66		81		81		90		110		124		134	157
Fit length	C	mm	22		27		31		36		36		41		43		51		45	55
Inner diameter from \varnothing to \varnothing H7	D_1/D_2	mm	8–28		10–30		12–32		14–42		19–42		22–45		24–60		35–60		40–75	50–80
Fastening screws to ISO 4762	E		M5		M6		M8		M10		M10		M12		M12		M16		2xM16 ^{a)}	2xM20 ^{a)}
Tightening torque of fastening screws	E	Nm	8		15		40		50		70		120		130		200		250	470
		in.lb	71		133		354		443		620		1062		1151		1770		2213	4160
Distance between centers	F	mm	17		19		23		27		27		31		39		41		2x48	2x55
Distance	G	mm	6.5		7.5		9.5		11		11		12.5		13		16.5		18	22.5
Moment of inertia	J	10^{-3}kgm^2	0.05	0.07	0.12	0.13	0.32	0.35	0.8	0.85	1.9	2	3.2	3.4	7.6	7.9	14.3	14.6	16.2	43.5
		10^{-3}in.lb.s^2	0.0443	0.0620	0.1062	0.1151	0.2832	0.3098	0.7081	0.7523	1.68	1.77	2.83	3.01	6.73	6.99	12.66	12.92	14.34	38.50
Hub material (standard) (steel on request)			Al		Al		Al		Al		Steel		Steel		Steel		Steel		Steel	Steel
Approx. weight		kg	0.16		0.26		0.48		0.8		1.85		2.65		4		6.3		5.7	11.5
		lb	0.353		0.573		1.764		1.764		4.079		5.842		8.818		13.889		12.566	25.353
Torsional rigidity	C_T	10^3Nm/rad	20	15	39	28	76	55	129	85	175	110	191	140	450	350	510	500	780	1304
Axial misalignment 		max. values mm	1	2	1	2	1.5	2	2	3	2	3	2	3	2.5	3.5	2.5	3.5	3.5	3.5
Lateral misalignment 		max. values mm	0.15	0.2	0.2	0.25	0.2	0.25	0.2	0.25	0.2	0.25	0.25	0.3	0.25	0.3	0.3	0.35	0.35	0.35
Axial spring stiffness	C_a	N/mm	25	15	50	30	72	48	48	32	82	52	90	60	105	71	70	48	100	320
Lateral spring stiffness	C_r	N/mm	475	137	900	270	1200	420	920	290	1550	435	2040	610	3750	1050	2500	840	2000	3600

^{a)} Two screws per clamping hub, 180° apart
Max. angular misalignment 1.5°

Bellows coupling BC2

With clamping hub

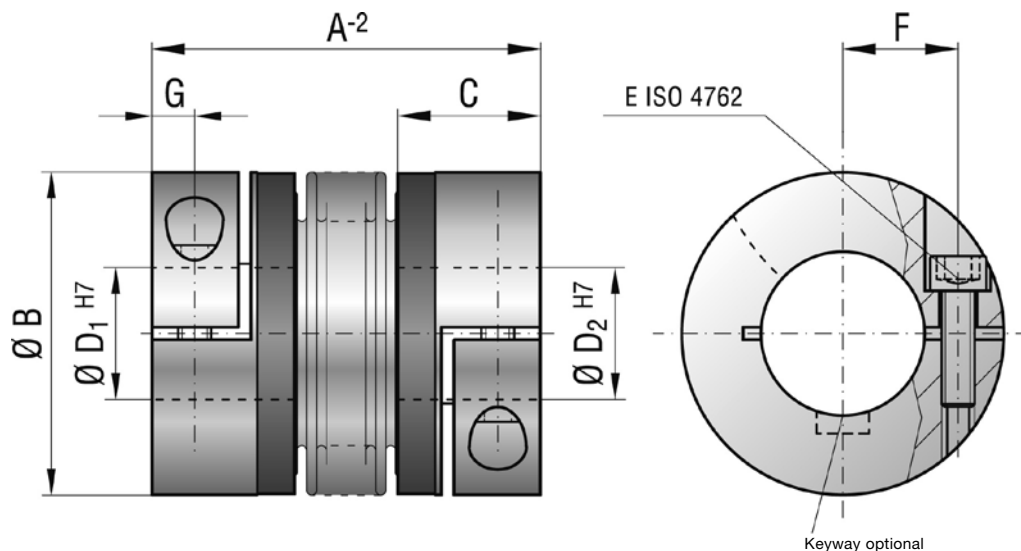

Bellows coupling for direct drives

Material:

Bellows made of highly flexible stainless steel.
Hub material: see table below.

Design:

With clamping hubs and a single lateral screw to ISO 4762.
Any imbalance of the clamping hubs due to the design is compensated by balancing bores located on the hub interior.

Temperature range: -30 °C to +120°C (-22 °F to 248 °F)

Backlash:

Completely backlash-free as a result of the frictional clamp connection.

Service life:

These torque limiters are permanent and maintenance-free as long as the performance limits are not exceeded.



Fit tolerance: Tolerance between shaft and hub 0.01 – 0.05 mm

Speeds:

Up to 10,000 rpm / in excess of 10,000 rpm with finely balanced version.

Brief overload: Acceptable up to 1.5 times the value specified.

BC3 – Bellows coupling

			Series																		
			15		30		60		150		200		300		500		800	1500	4000	6000	10000
Length options (see ordering code)			A	B	A	B	A	B	A	B	A	B	A	B	A	A	A	A	A		
Rated torque	T_{KN}	Nm in.lb	15		30		60		150		200		300		500		800	1500	4000	6000	10000
			133		266		531		1328		1770		2655		4425		7080	13275	35400	53100	88500
Overall length without screw head	A	mm	48	55	57	65	66	76	75	87	78	90	89	103	97	110	114	141	195	210	217
Outer diameter	B	mm	49		55		66		81		90		110		124		133	157	200	253	303
Fit length	C	mm	19		22		27		32		32		41		41		50	61	80	85	92
Inner diameter from Ø to Ø H7	D_1/D_2	mm	10–22		12–23		12–29		15–38		15–44		24–56		24–60		30–60	35–70	50–100	60–140	70–180
6 x fastening screws to ISO 4017	E		M4		M5		M5		M6		M6		M8		M8		M10	M12	M16	M16	8xM16
Tightening torque of fastening screws	E	Nm in.lb	4		6		8		12		14		18		25		40	70	120	150	160
			36		54		71		107		124		160		222		354	620	1062	1328	1416
3 x jack screws to ISO 4017	F		M4		M4		M5		M5		M6		M6		M6		M6	6xM8	6xM10	6xM10	8xM10
Outer diameter of hub	G	mm	49		55		66		81		90		110		122		116	135	180	246	295
Moment of inertia	J	10^{-3}kgm^2 10^{-3}in.lb.s^2	0.08	0.08	0.15	0.16	0.39	0.41	1.2	1.6	1.7	2.5	5.1	5.9	9.1	9.9	13.2	34.9	85.5	254	629
			0.071	0.073	0.13	0.14	0.35	0.36	1.06	1.42	1.5	2.21	4.51	5.22	8.05	8.76	11.7	30.9	75.7	224.8	556.7
Approx. weight		kg lb	0.26	0.27	0.42	0.44	0.71	0.74	1.2		1.8		3		4.2		5.6	8.2	23	32.6	45.5
			0.57	0.60	0.93	0.97	1.57	1.63	2.65		3.97		6.61		9.33		12.3	18.1	50.7	71.9	100.3
Torsional rigidity	C_r	10^3Nm/rad	20	15	39	28	76	55	175	110	191	140	450	350	510	500	780	1304	3400	5700	10950
Axial misalignment 	<i>max. values</i>	mm	1	2	1	2	1.5	2	2	3	2	3	2.5	3.5	2.5	3.5	3.5	3.5	3.5	3	3
Lateral misalignment 	<i>max. values</i>	mm	0.15	0.2	0.2	0.25	0.2	0.25	0.2	0.25	0.25	0.3	0.25	0.3	0.3	0.35	0.35	0.35	0.4	0.4	0.4
Axial spring stiffness	C_a	N/mm	25	15	50	30	72	48	82	52	90	60	105	71	70	48	100	320	565	1030	985
Lateral spring stiffness	C_r	N/mm	475	137	900	270	1200	420	1500	435	2040	610	3750	1050	2500	840	2000	3600	6070	19200	21800

Max. angular misalignment 1.5°

Bellows coupling BC3

With conical connection

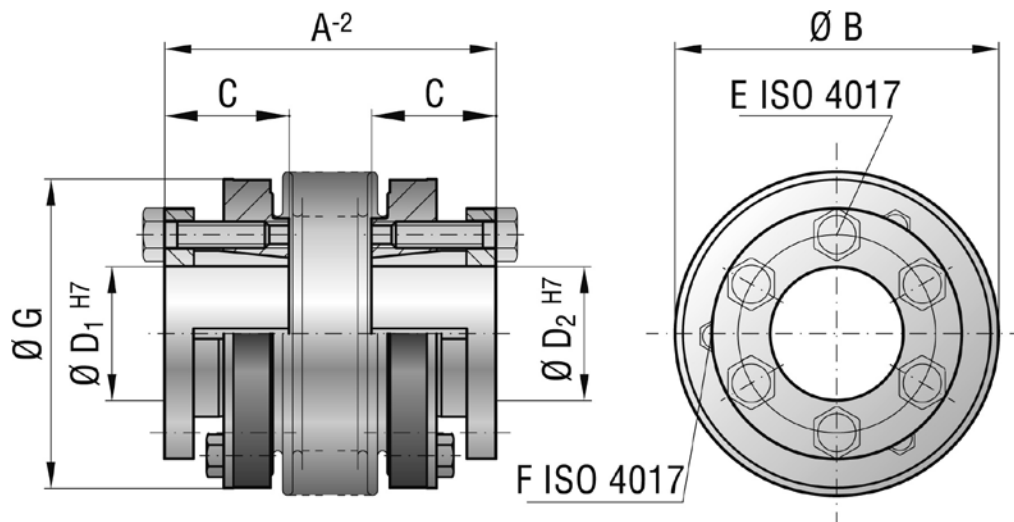

Bellows coupling for direct drives

Material:

Bellows made of highly flexible stainless steel.
Hub material: steel.

Design:

With split conical clamping hubs and strong, captive jack screws to ISO 4017.

Temperature range: -30 °C to +120°C (-22 °F to 248°F)

Backlash:

Completely backlash-free as a result of the frictional clamp connection.

Service life:

These torque limiters are permanent and maintenance-free as long as the performance limits are not exceeded.



Fit tolerance: Tolerance between shaft and hub 0.01 – 0.05 mm

Speeds:

Up to 10000 rpm / in excess of 10000 rpm with finely balanced version.

Brief overload: Acceptable up to 1.5 times the value specified.

EC2 – Bellows coupling

			Series												
			2	4.5	10	15	30	60	80	150		300		500	
Length options see ordering code			A	A	A	A	A	A	A	A	B	A	B	A	B
Rated torque	T_{KN}	Nm in.lb	2	4.5	10	15	30	60	80	150		300		500	
			18	40	89	133	266	531	708	1328		2655		4425	
Overall length	A	mm	30	40	44	58	68	79	92	92		109		114	
Outer diameter	B	mm	25	32	40	49	56	66	82	82		110		123	
Fit length	C	mm	10.5	13	13	21.5	26	28	32.5	32.5		41		42.5	
Inner diameter from \varnothing to \varnothing H7	D_1/D_2	mm	4–12.7	6–16	6–24	8–28	12–32	14–35	16–42	19–42		24–60		35–62	
Fastening screws to ISO 4762	E		M3	M4	M4	M5	M6	M8	M10	M10		M12		M16	
Tightening torque of fastening screw	E	Nm in.lb	2.3	4	4.5	8	15	40	70	85		120		200	
			21	36	40	71	133	354	620	753		1062		1770	
Distance between centers	F	mm	8	11	14	17	20	23	27	27		39		41	
Distance	G	mm	4	5	5	6.5	7.5	9.5	11	11		13		17	
Moment of inertia	J	10^{-3}kgm^2 10^{-3}in.lb.s^2	0.002	0.007	0.016	0.065	0.12	0.3	0.75	1.8	0.8	7.5	3.8	11.7	4.9
			0.0018	0.0062	0.0142	0.0575	0.1062	0.2655	0.6638	1.59	0.71	6.64	3.36	10.36	4.34
Hub material			Al	Al	Al	Al	Al	Al	Al	Steel	Al	Steel	Al	Steel	Al
Approx. weight		kg lb	0.02	0.05	0.06	0.16	0.25	0.4	0.7	1.7	0.75	3.8	1.6	4.9	2.1
			0.044	0.110	0.132	0.353	0.551	0.882	1.54	3.75	1.65	8.38	3.53	10.80	4.63
Torsional rigidity	C_T	10^3Nm/rad	1.5	7	9	23	31	72	80	141		157		290	
Axial misalignment 	\rightarrow max. values	mm	0.5	1	1	1	1	1.5	2	2		2		2.5	
Lateral misalignment 	\rightarrow max. values	mm	0.2	0.2	0.2	0.2	0.2	0.2	0.2	0.2		0.2		0.2	
Axial spring stiffness	C_a	N/mm	8	35	30	30	50	67	44	77		112		72	
Lateral spring stiffness	C_r	N/mm	50	350	320	315	366	679	590	960		2940		1450	

Max. angular misalignment 1°

Bellows coupling EC2

With clamping hub

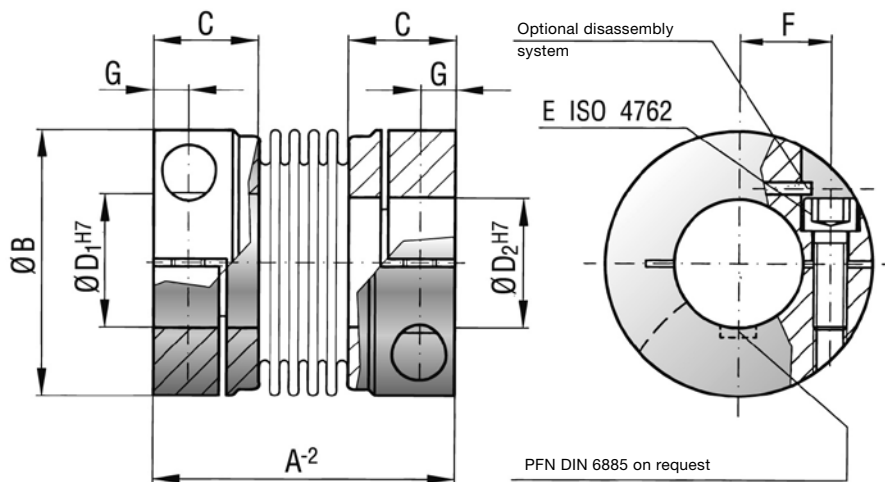

Bellows coupling for direct drives

Material:

Bellows made of highly flexible stainless steel.
Hub material: see table below.

Design:

With clamping hubs and a single lateral screw to ISO 4762.

Temperature range: -30 °C to +100°C (-22 °F to 212 °F)

Backlash:

Completely backlash-free as a result of the frictional clamp connection.

Service life:

These torque limiters are permanent and maintenance-free as long as the performance limits are not exceeded.

Fit tolerance: Tolerance between shaft and hub 0.01 – 0.05 mm

Optional self-opening clamp system:

For expanding the bore hole during assembly or dismantling.

Accessories and supplementary instructions

Torque adjusting wrench for DIN 1816 nuts

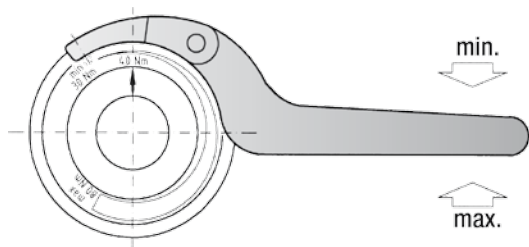

Smaller coupling sizes do not require a torque adjusting wrench. The adjusting nuts for the 1.5/2/4.5/10 series can be adjusted with a bolt or pin.

Series	Torque adjusting wrench	
	Standard version	Full disengagement version
15	AC 20047730	AC 20047730
30	AC 20047731	AC 20047731
60	AC 20047732	AC 20047749
80/150	AC 20047733	AC 20047733
200	AC 20047734	AC 20047750
300	AC 20047735	AC 20047735
500	AC 20047736	AC 20047736
800	AC 20047737	AC 20047751
1500	AC 20047738	AC 20047738
2500	AC 20047739	AC 20047752

Mechanical limit switch (emergency cut-off)

Dimension drawings

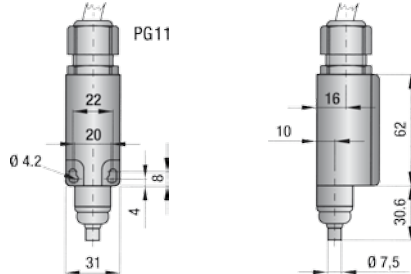

Important:
Always carry out a 100 % test of the switch function after assembly.

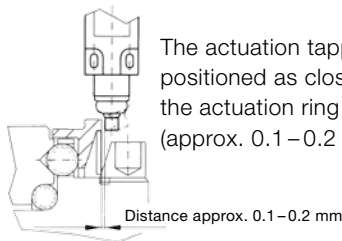

The actuation tappet should be positioned as close as possible to the actuation ring of the torque limiter (approx. 0.1–0.2 mm).

Technical data	
Max. voltage:	500 V AC
Max. constant current:	10 A
Degree of protection:	IP 65
Contact type:	NC contact (positive opening)
Ambient temperature:	-30 °C to +80 °C
Actuation:	Tappet (metal)
Circuit symbol:	

The mechanical limit switch is suitable for size 30 and above.

Proximity switch (emergency cut-off)

Dimension drawings

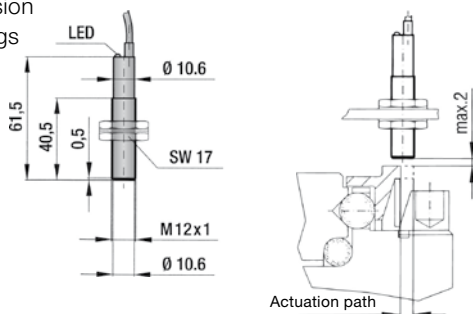

Important:
Always carry out a 100 % test of the switch function after assembly.

Technical data	
Voltage range:	10 to 30 V DC
Max. output current:	200 mA
Max. switching frequency:	800 Hz
Temperature range:	-25 °C to +70 °C
Degree of protection:	IP 67
Switch type:	PNP NC contact
Detection gap:	max. 2 mm
Circuit symbol:	

Assembly instructions for low backlash torque limiters

For the TL 1–TL 3 models, the fit tolerance between the shaft and hub must be between 0.01 and 0.05 mm. Ensure that the coupling hub mounts smoothly on the shaft prior to assembly. Lightly oil the shaft prior to assembly. Do not use oils or grease with sliding additives (for example, MoS₂). Any keyways in the shaft will not affect the functioning of the clamp connection.

Model TL1 has an integrated **bearing (1)** for the attached component (for example, a pulley or sprocket wheel). Do not exceed the **maximum radial force (2)**, (see table). By centering the load between the **dimension (S)**, sufficient force is applied between the two balls and no separate bearings are required. Additional bearings are required for offset mounting. This is recommended, for example, if the attached component has a very small diameter or a very large width. Ball bearings, needle bearings or bushings can be used depending on the installation situation.

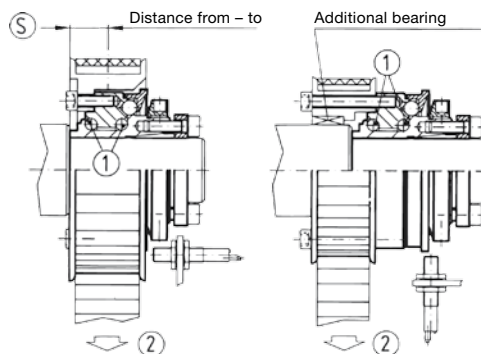

Series	1.5	2	4.5	10	15	30	60	150	200	300	500	800	1500	2500
Max. radial load capacity (N)	50	100	200	500	1400	1800	2300	3000	3500	4500	5600	8000	12000	20000
(S) from – to	3–6	5–8	5–11	6–14	7–17	10–24	10–24	12–24	12–26	12–28	16–38	16–42	20–50	28–60

Adjustment of the disengagement torque

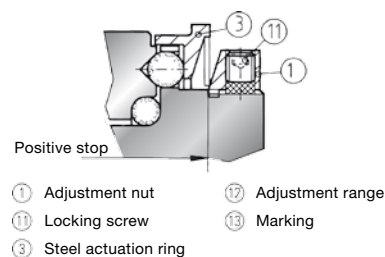
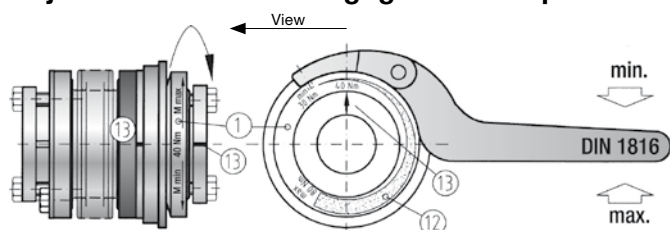

WITTENSTEIN alpha torque limiters are factory adjusted to the specified disengagement torque, which is marked on the coupling. The adjustment range (min./max.) is indicated on the **adjustment nut (1)**. The customer can adjust the disengagement torque infinitely within the **adjustment range (12)** by varying the pretension of the disc springs. The adjustment range must not be exceeded during the adjustment process. After loosening the **lock screw (11)**, the disengagement torque can be adjusted using a suitable tool, e.g. a torque adjusting wrench to DIN 1816. The three locking screws **(11)** should then be tightened again.

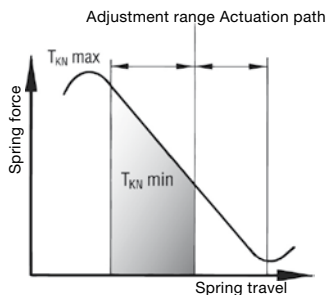

Important!

WITTENSTEIN alpha torque limiters incorporate disc springs with special spring characteristics. Never exceed the max./min. range of the disengagement torque, which is located along the downward slope of this characteristic curve.

$$T_{2m} \approx \frac{1}{\sqrt{J_s + J_L}} \cdot (T_{2b} + T_{2n}) \cdot S_s \text{ [Nm]}$$

Important information

$$T_{2m} = \sqrt{\frac{|n_{2b}| \cdot t_b \cdot |T_{2b}|^3 + \dots + |n_{2n}| \cdot t_n \cdot |T_{2n}|^3}{|n_{2b}| \cdot t_b + \dots + |n_{2n}| \cdot t_n}}$$

Read the following pages for information on quick selection, configuration, design and handling of your WITTENSTEIN alpha gearhead.

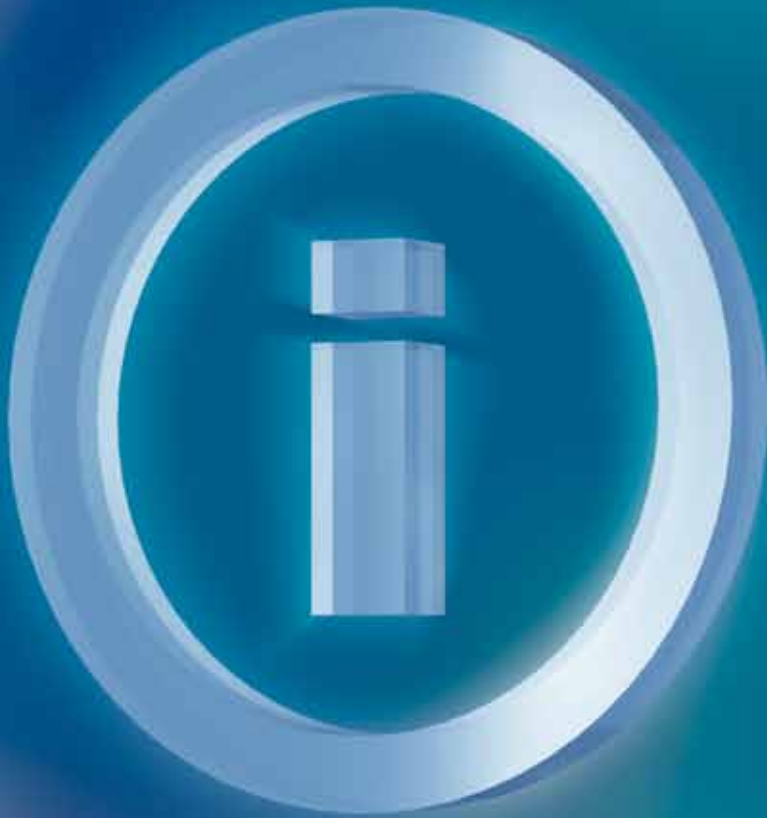



Quick gearhead selection

The quick gearhead selection feature is designed exclusively for calculating gearhead sizes approximately. Quick selection is not a substitute for the detailed design feature! To select a specific gearhead, proceed as described in the Chapter „Gearhead – Detailed design“ or „V-Drive® – Detailed design“. For quick, convenient and reliable gearhead selection, we recommend using WITTENSTEIN alpha's cymex® design software.

<p>Cyclic operation S5</p> <p>Valid for ≤ 1000 cycles/hour</p> <p>Duty cycle < 60 % and < 20 min.^{a)}</p>	<ol style="list-style-type: none"> 1. Calculate the max. motor acceleration torque using motor data T_{MaxMot} [Nm] or [in.lb] 2. Calculate the max. available acceleration torque at the gearhead output T_{2b} [Nm] or [in.lb] $T_{2b} = T_{MaxMot} \cdot i$ 3. Compare the max. available acceleration torque T_{2b} [Nm] or [in.lb] with the max. permissible acceleration torque T_{2B} [Nm] or [in.lb] at the gearhead output $T_{2b} \leq T_{2B}$ 	<ol style="list-style-type: none"> 4. Compare the bore hole diameter on the clamping hub (see technical data sheets) 5. Compare the motor shaft length L_{Mot} [mm] or [in] with the min. and max. dimensions in the corresponding dimension sheet
<p>Continuous operation S1</p> <p>Duty cycle ≥ 60 % or ≥ 20 min.^{a)}</p>	<ol style="list-style-type: none"> 1. Select cyclic operation S5 2. Calculate the rated motor torque T_{1NMot} [Nm] or [in.lb] 3. Calculate the previous rated torque at the gearhead output T_{2n} [Nm] or [in.lb] $T_{2n} = T_{1NMot} \cdot i$ 	<ol style="list-style-type: none"> 4. Compare the previous rated torque T_{2n} [Nm] or [in.lb] with the permissible nominal torque T_{2N} [Nm] or [in.lb] at the gearhead output $T_{2n} \leq T_{2N}$ 5. Calculate the previous input speed n_{1n} [rpm] 6. Compare the previous input speed n_{1n} [rpm] with the permissible rated speed n_{1N} [rpm] $n_{1n} \leq n_{1N}$

^{a)} recommended by WITTENSTEIN alpha. Please contact us if you require further assistance.

Gearhead – Detailed design

Cyclic operation **S5** and continuous operation **S1**

Calculate the duty cycle ED

$$ED = \frac{(t_b + t_c + t_d)}{(t_b + t_c + t_d + t_e)} \cdot 100 [\%]$$

$$ED = t_b + t_c + t_d \text{ [min]}^a)$$

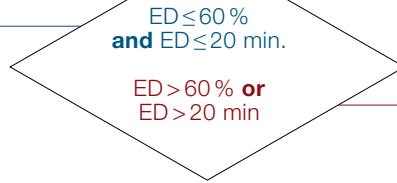

Cyclic operation:
Use standard gearhead:

Continuous operation: recommended
Use SP+ HIGH SPEED® or LP+
(otherwise consult us)

$$Z_h^a) = \frac{3600 \text{ [s/h]}}{(t_b + t_c + t_d + t_e)}$$

^{a)} see diagram 1 "Load factor"

f_s is dependent on Z_h (diagram 1)

T_{2b} = depends on the application

$$T_{2b, fs} = T_{2b} \cdot f_s$$

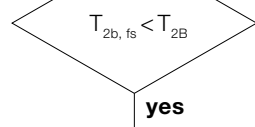
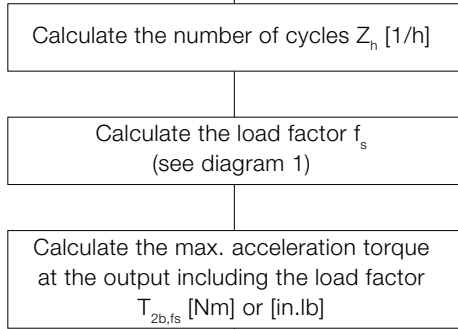

Select a larger gearhead

n_{2max} depends on the application

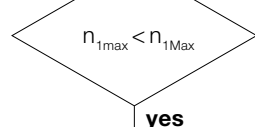
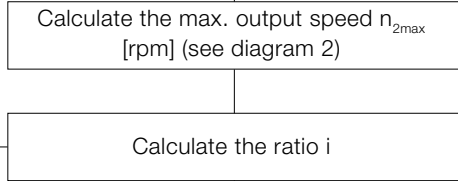

Smaller ratio i

i depends on
 n – required output speed (for the application)
 – reasonable input speed (gearhead/motor)

$$n_{1max} = n_{2max} \cdot i$$

$$n_{1max} \leq n_{1Mot max}$$

T – consisting of corresponding output and input torque

$$T_{1b} = T_{2b} \cdot \frac{1}{i} \cdot \frac{1}{\eta} \quad T_{1b} \leq T_{Mot max}$$

λ – from resulting inertia ratio.
 Guide value: $1 \leq \lambda \leq 10$
 (see **alphabet** for calculation)

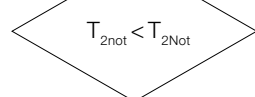
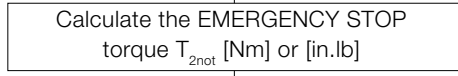

Select a larger gearhead

T_{2not} depends on the application

Please refer to the relevant technical data for information on the max. permissible characteristic values for your gearhead. To design a V-Drive® gearhead, see Chapter "V-Drive® – Detailed design".

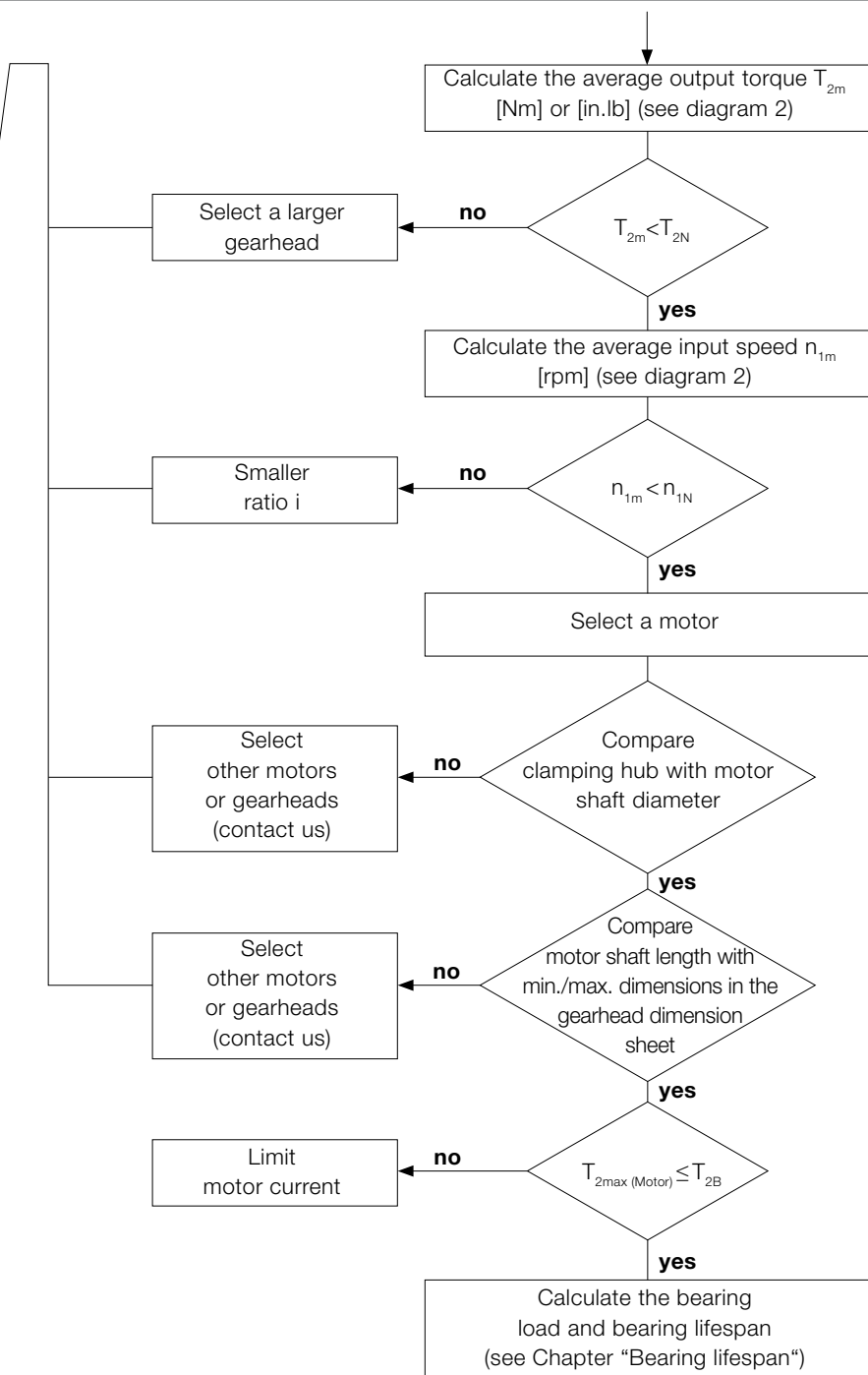

$$T_{2m} = \sqrt[3]{\frac{|n_{2b}| \cdot t_b \cdot |T_{2b}|^3 + \dots + |n_{2n}| \cdot t_n \cdot |T_{2n}|^3}{|n_{2b}| \cdot t_b + \dots + |n_{2n}| \cdot t_n}}$$

$$n_{2m} = \frac{|n_{2b}| \cdot t_b + \dots + |n_{2n}| \cdot t_n}{t_b + \dots + t_n} \text{ incl. pause time}$$

$$n_{1m} = n_{2m} \cdot i$$

$$D_{W, Mot} \leq D_{\text{clamping hub}}$$

The motor shaft must be inserted far enough into the clamping hub.

1. The motor shaft must protrude far enough into the clamping hub without making contact.

$$T_{2max (Motor)} = T_{1max (Motor)} \cdot i \cdot \eta_{\text{gearhead}}$$

2. The gearhead should not be damaged when the motor operates at full load, limit the motor current if necessary.

Diagram 1
Large number of cycles combined with short acceleration times may cause the drive train to vibrate. Use the load factor f_s to include the resulting excess torque values in calculations.

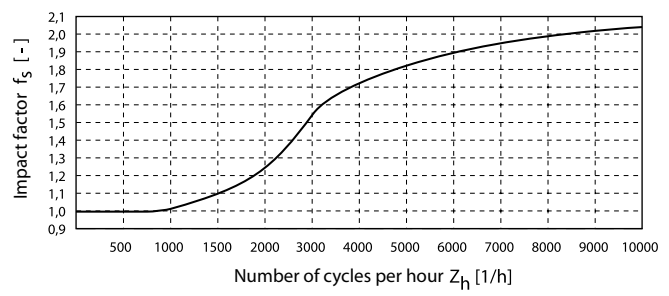
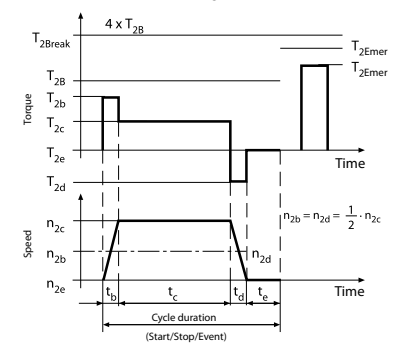
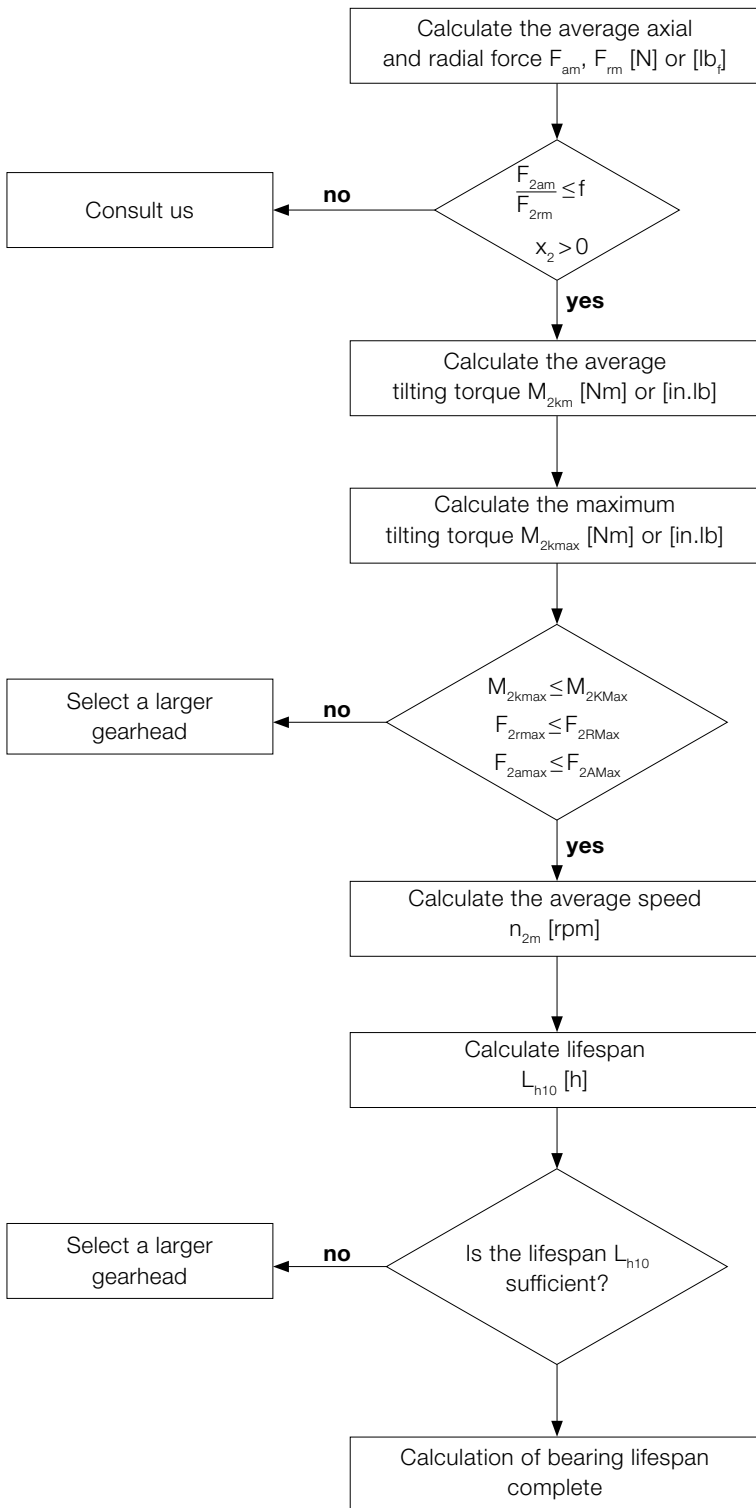

Diagram 2
Standard collective load at output
If the load on the gearhead in continuous operation S1 is less than or equal to the rated torque T_{2N} , the gearing is. At input speeds less than/equal to the rated speed n_{1N} , the temperature of the gearhead will not exceed 90 °C under average ambient conditions.



Bearing lifespan L_{h10} (output bearing)



$$F_{2am} = \sqrt[3]{\frac{|n_{2b}| \cdot t_b \cdot |F_{2ab}|^3 + \dots + |n_{2n}| \cdot t_n \cdot |F_{2an}|^3}{|n_{2b}| \cdot t_b + \dots + |n_{2n}| \cdot t_n}}$$

$$F_{2rm} = \sqrt[3]{\frac{|n_{2b}| \cdot t_b \cdot |F_{2rb}|^3 + \dots + |n_{2n}| \cdot t_n \cdot |F_{2rn}|^3}{|n_{2b}| \cdot t_b + \dots + |n_{2n}| \cdot t_n}}$$

$$M_{2km} = \frac{F_{2am} \cdot y_2 + F_{2rm} \cdot (x_2 + z_2)^a}{W}$$

$$M_{2kmax} = \frac{F_{2amax} \cdot y_2 + F_{2rmax} \cdot (x_2 + z_2)^a}{W}$$

^{a)} x_2, y_2, z_2 in mm or in

$$n_{2m} = \frac{n_{2b} \cdot t_b + \dots + n_{2n} \cdot t_n}{t_b + \dots + t_n}$$

$$L_{h10} = \frac{16666}{n_{2m}} \cdot \left[\frac{K1_2}{M_{2km}} \right]^{p_2}$$

	metric	inch
W	1000	1

	TP ⁺ /TPK ⁺	SP ⁺ /SPK ⁺	LP ⁺ /LPB ⁺ LPK ⁺	alphira [®] (CP)
f	0.37	0.40	0.24	0.24

LP ⁺ /LPB ⁺ /LPK ⁺	050	070	090	120	155	
z ₂	[mm]	20	28.5	31	40	47
	[in]	0.79	1.12	1.22	1.58	1.85
K1 ₂	[Nm]	75	252	314	876	1728
	[in.lb]	664	2230	2779	7753	15293
p ₂	3	3	3	3	3	

alphira [®] (CP)	040	060	080	115	
z ₂	[mm]	12.5	19.5	23.5	28.5
	[in]	0.49	0.77	0.93	1.12
K1 ₂	[Nm]	15.7	70.0	157.0	255.0
	[in.lb]	139	620	1389	2257
p ₂	3	3	3	3	

Example with output shaft and flange:

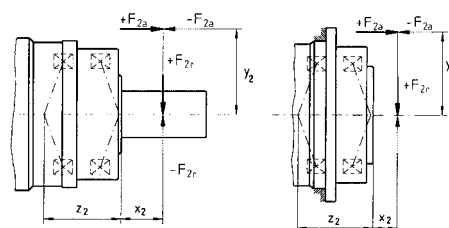

SP ⁺ /SPK ⁺	060	075	100	140	180	210	240	
z ₂	[mm]	42.2	44.8	50.5	63.0	79.2	94.0	99.0
	[in]	1.66	1.76	1.99	2.48	3.12	3.70	3.90
K1 ₂	[Nm]	795	1109	1894	3854	9456	15554	19521
	[in.lb]	7036	9815	16762	34108	83686	137653	172761
p ₂	3.33	3.33	3.33	3.33	3.33	3.33	3.33	

TP ⁺ /TPK ⁺	004	010	025	050	110	300	500	
z ₂	[mm]	57.6	82.7	94.5	81.2	106.8	140.6	157
	[in]	2.27	3.26	3.72	3.20	4.21	5.48	6.12
K1 ₂	[Nm]	536	1325	1896	4048	9839	18895	27251
	[in.lb]	4744	11726	16780	35825	87075	167220	241171
p ₂	3.33	3.33	3.33	3.33	3.33	3.33	3.33	

TK⁺/SK⁺/HG⁺/LK⁺: Calculation using cymex[®].
Please contact us for further information.

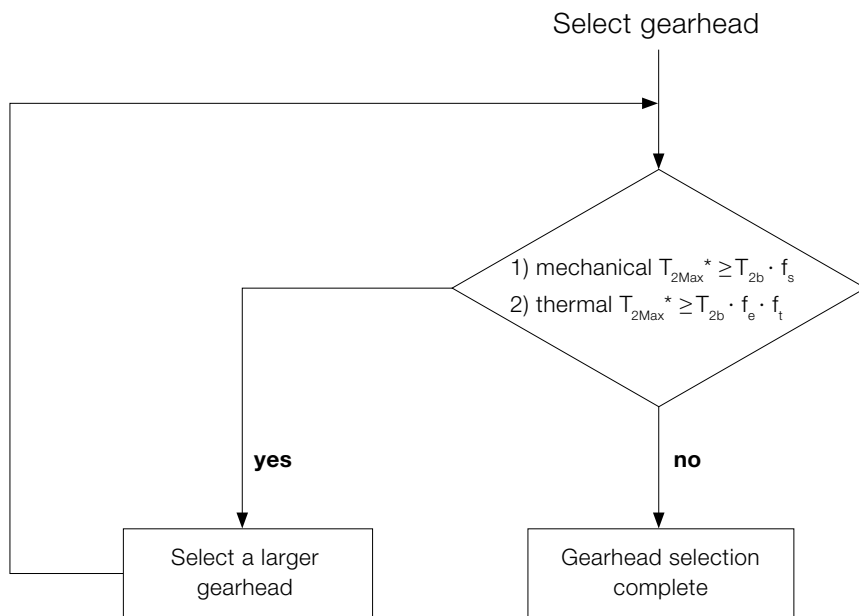

Cycles per hour	Load factor f_s
0	1
1000	1,3
3000	1,9
6000	2,2
10000	2,3

Duty cycle for each hour (ED %)	f_e for duty cycle
100	1
80	0,94
60	0,86
40	0,74
20	0,56

Temperature factor f_t												
	VD 050						VD 063					
Ratio	4	7	10	16	28	40	4	7	10	16	28	40
$n_{IN} = 500$ rpm	0,53	0,53	0,53	0,53	0,53	0,53	0,53	0,53	0,53	0,53	0,53	0,53
$n_{IN} = 1000$ rpm	0,53	0,53	0,53	0,53	0,53	0,53	0,53	0,53	0,53	0,56	0,65	0,57
$n_{IN} = 2000$ rpm	0,53	0,53	0,53	0,56	0,61	0,53	0,76	0,95	0,94	0,99	1,06	1,01
$n_{IN} = 3000$ rpm	0,57	0,75	0,78	0,86	0,95	0,79	1	1,11	1,23	1,32	1,42	1,38
$n_{IN} = 4000$ rpm	0,89	1,16	1,22	1,16	1,28	1,23	1,44	1,56	1,74	1,9	2,07	2,03
	VD 080						VD 100					
Ratio	4	7	10	16	28	40	4	7	10	16	28	40
$n_{IN} = 500$ rpm	0,53	0,53	0,54	0,57	0,64	0,53	0,62	0,7	0,72	0,73	0,79	0,69
$n_{IN} = 1000$ rpm	0,7	0,82	0,8	0,83	0,88	0,78	0,79	0,93	0,98	0,99	1,09	0,94
$n_{IN} = 2000$ rpm	0,9	1,12	1,1	1,28	1,37	1,2	1,18	1,3	1,4	1,44	1,62	1,53
$n_{IN} = 3000$ rpm	1,22	1,58	1,57	1,88	2,03	1,78	1,83	1,96	2,16	2,24	2,56	2,46
$n_{IN} = 3500$ rpm	1,66	1,78	1,79	2,16	2,35	2,06	–	–	–	–	–	–

T_{2Max}^* = maximum torque which can be transmitted by the gearbox
 T_{2b} = process torque

Ratios $i = 28$ and $i = 40$ are self-locking at zero speed. The self-locking state may be overcome and therefore the gearhead should not replace a brake. For applications that run at a continuous speed of 3000 rpm or more in installation position F or G, please contact us.

* For applications requiring high precision over the life of the application, use T_{2Servo}

Bearing lifespan L_{h10} (output bearing)

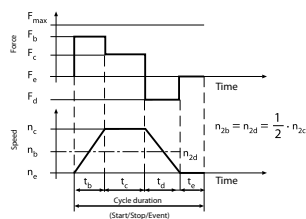

Output (VDT+, VDH+, VDHe, VDS+ & VDS+ version)

Calculate the average axial and radial force F_{2am} , F_{2rm} [N]

Index "2" $\hat{=}$ output

no $\frac{F_{2am}}{F_{2rm}} \leq 0.4$ $x_2 > 0$ yes

$$F_{2am} = \sqrt[3]{\frac{n_{2b} \cdot t_b \cdot F_{2ab}^3 + \dots + n_{2n} \cdot t_n \cdot F_{2an}^3}{n_{2b} \cdot t_b + \dots + n_{2n} \cdot t_n}}$$

$$F_{2rm} = \sqrt[3]{\frac{n_{2b} \cdot t_b \cdot F_{2rb}^3 + \dots + n_{2n} \cdot t_n \cdot F_{2rn}^3}{n_{2b} \cdot t_b + \dots + n_{2n} \cdot t_n}}$$

$$M_{2km} = \frac{F_{2am} \cdot y_2 + F_{2rm} \cdot (x_2 + z_2)}{W}$$

Z_2 [mm]	VDT+	VDH+/VDHe/ VDS+	VDS+
VD050	104	71.5	92.25
VD063	113.5	82	111.5
VD080	146.75	106.25	143.25
VD100	196	145.5	181

$$M_{2kmax} = \frac{F_{2amax} \cdot y_2 + F_{2rmax} \cdot (x_2 + z_2)}{W}$$

Version	VD 050	VD 063	VD 080	VD 100
$M_{2K Max}$ [Nm]	409	843	1544	3059
$F_{2R Max}$ [N]	3800	6000	9000	14000
$F_{2A Max}$ [N]	5000	8250	13900	19500

Calculate the average tilting torque M_{2km} [Nm] or [in.lb]

Calculate the maximum tilting torque M_{2kmax} [Nm] or [in.lb]

no $M_{2kmax} \leq M_{2K Max}$
 $F_{2rmax} \leq F_{2R Max}$
 $F_{2amax} \leq F_{2A Max}$ yes

Consult us!

	metric
W	1000

Select a larger gearhead

$K1_2$ [Nm]	VDT+	VDH+/VDHe/ VDS+	VDS+
VD 050	3050	2320	2580
VD 063	4600	3620	5600
VD 080	9190	9770	10990
VD 100	20800	15290	20400

$$n_{2m} = \frac{n_{2b} \cdot t_b + \dots + n_{2n} \cdot t_n}{t_b + \dots + t_n}$$

Calculate the average speed n_{2m} [rpm]

P_t	T/H/S
i=4	1.5
i=7	0.72
i=10	0.6
i=16	0.5
i=28	0.4
i=40	0.36

$$L_{h10} = \frac{16666}{n_{2m}} \cdot \left[\frac{K1_2}{p_t \cdot T_{2m} + M_{2km}} \right]^{3.33}$$

Calculate the lifespan L_{h10} [h]

no lifespan L_{h10} sufficient? yes

Torque selection complete

VDS+ involute

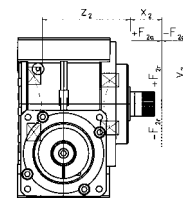

VDS+ / VDS+ smooth, keywayed

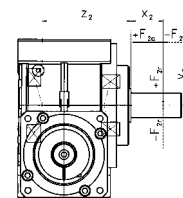

VDH+ / VDHe smooth

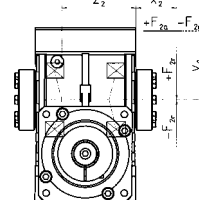

VDT+

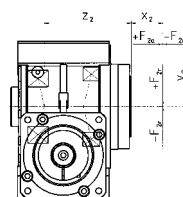

VDH+ / VDHe keywayed

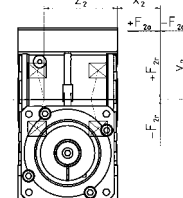

Rating for torque limiters

According to disengagement torque

As a rule, torque limiters are rated according to the required disengagement torque, which must be greater than the torque required for normal machine operation. The disengagement torque of the torque limiters is usually calculated in accordance with the drive specifications. The following calculation has proved to be a good rule of thumb:

$$T_{KN} \geq 1.5 \cdot T_{2b} \text{ [Nm]}$$

or

$$T_{KN} \geq 9550 \cdot \frac{P_{AN}}{n} \cdot 1.5 \text{ [Nm]}$$

T_{KN} = rated coupling torque [Nm]

T_{2b} = max. available acceleration torque [Nm]

According to acceleration torque (start-up at no load)

S_A = Impact or load factor
 $S_A = 1$ (uniform load)
 $S_A = 2$ (non-uniform load)
 $S_A = 3$ (impact load)

$$T_{KN} \geq \alpha \cdot J_L \geq \frac{J_L}{J_A + J_L} \cdot T_{2b} \cdot S_A \text{ [Nm]}$$

Values of $S_A = 2-3$ are usual for servo drives on machine tools.

T_{KN} = rated coupling torque [Nm]

α = angular acceleration [1/s²]

$$\alpha = \frac{\omega}{t} = \frac{\pi \cdot n}{t \cdot 30} \left[\frac{1}{s^2} \right]$$

t = acceleration time [sec.]

ω = angular speed [1/s]

n = drive speed [rpm]

J_L = moment of inertia on load side [kgm²]

J_A = moment of inertia on drive side [kgm²]

T_{2b} = max. available acceleration torque [Nm]

According to acceleration and load torque

$$T_{KN} \geq \alpha \cdot J_L + T_{AN} \geq \left[\frac{J_L}{J_A + J_L} \cdot (T_{2b} - T_{AN}) + T_{AN} \right] \cdot S_A \text{ [Nm]}$$

S_A = Impact or load factor
 $S_A = 1$ (uniform load)
 $S_A = 2$ (non-uniform load)
 $S_A = 3$ (impact load)

Values of $S_A = 2-3$ are usual for servo drives on machine tools.

T_{KN} = rated coupling torque [Nm]

α = angular acceleration [1/s²]

t = acceleration time [sec.]

ω = angular speed [1/s]

n = drive speed [rpm]

J_L = moment of inertia on load side [kgm²]

T_{AN} = load torque [Nm]

J_A = moment of inertia on drive side [kgm²]

T_{2b} = max. available acceleration torque [Nm]

According to feed force

Spindle drive

$$T_{AN} = \frac{s \cdot F_V}{2000 \cdot \pi \cdot \eta} \text{ [Nm]}$$

Timing belt drive

$$T_{AN} = \frac{d_0 \cdot F_V}{2000} \text{ [Nm]}$$

T_{AN} = load torque [Nm]

S = ball screw pitch [mm]

F_V = feed force [N]

η = spindle efficiency

T_{AN} = load torque [Nm]

d_0 = pinion diameter (timing belt pulley) [mm]

F_V = feed force [N]

According to resonant frequency (TL 2 / 3 with bellows attachment)

The resonant frequency of the coupling must be higher or lower than the machine frequency. For the purpose of calculation, the drive is reduced to a two-mass system:

$$f_e = \frac{1}{2 \cdot \pi} \sqrt{C_T \cdot \frac{J_{Mach} + J_A}{J_{Mach} \cdot J_A}} \text{ [Hz]}$$

C_T = torsional rigidity of coupling [Nm/rad]

J_{Mach} = moment of inertia of machine [kgm²]

J_A = moment of inertia on drive side [kgm²]

f_e = resonant frequency of two-mass system [Hz]

According to torsional rigidity (TL 2 / 3 with bellows attachment)

Transmission errors due to a torsional load on the metal bellows:

$$\varphi = \frac{180}{\pi} \cdot \frac{T_{2b}}{C_T} \quad [\text{degrees}]$$

φ = angle of turn [degrees]
 C_T = torsional rigidity of coupling [Nm/rad]
 T_{2b} = max. available acceleration torque [Nm]

According to the function system

Load holding version: On TL 1 and TL models, the load holding version has a double load safety margin. Ensure that models with a bellows attachment (TL 2 / 3) are of adequate size. The blocking load in this case should not exceed the rated torque of the coupling.

Rating for bellows couplings

According to torque

In most cases, the couplings should be rated according to the maximum peak torque to be transmitted regularly. The peak torque must not exceed the rated torque of the coupling, i.e. the torque that can be transmitted continuously within the permissible speed and misalignment ranges. The following formula has proved to be a good rule of thumb:

$$T_{KN} \geq 1.5 \cdot T_{2b} \quad [\text{Nm}]$$

T_{KN} = rated coupling torque [Nm]
 T_{2b} = max. available acceleration torque [Nm]

According to acceleration torques

For precise rating, the acceleration torque and the moment of inertia of the entire machine should be taken into consideration. Especially with servo motors, ensure that the acceleration or deceleration torque is several times greater than the rated torque.

$$T_{KN} \geq T_{2b} \cdot S_A \cdot \frac{J_L}{J_A + J_L} \quad [\text{Nm}]$$

T_{KN} = rated torque of coupling [Nm]

T_{2b} = max. available acceleration torque [Nm]
 J_L = moment of inertia of machine [kgm²]
 J_A = moment of inertia on drive side [kgm²]

S_A = Impact or load factor
 $S_A = 1$ (uniform load)
 $S_A = 2$ (non-uniform load)
 $S_A = 3-4$ (impact load)

Values of $S_A = 2-3$ are usual for servo drives on machine tools.

According to resonant frequency

The resonant frequency of the coupling must be higher or lower than the machine frequency. For the purpose of calculation, the drive is reduced to a two-mass system:

In practice you should use: $f_e \geq 2 \times f_{er}$

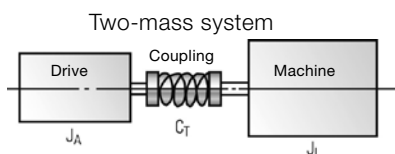

$$f_e = \frac{1}{2 \cdot \pi} \sqrt{C_T \cdot \frac{J_A + J_L}{J_A \cdot J_L}} \quad [\text{Hz}]$$

C_T = torsional rigidity of coupling [Nm/rad]
 f_e = natural frequency of 2-mass system [Hz]
 f_{er} = excitation frequency of drive [Hz]

According to torsional rigidity

Transmission errors due to a torsional load on the metal bellows:

$$\varphi = \frac{180}{\pi} \cdot \frac{T_{2b}}{C_T} \quad [\text{degrees}]$$

φ = angle of turn [degrees]
 C_T = torsional rigidity of coupling [Nm/rad]
 T_{2b} = max. available acceleration torque [Nm]

Sizing of a **Elastomer Coupling**

Temperature factor S_{θ}	A	B	C
Temperature (θ)	Sh 98 A	Sh 64 D	Sh 80 A
> -30 °C to -10 °C	1.5	1.7	1.4
> -10 °C to +30 °C	1.0	1.0	1.0
> +30 °C to +40 °C	1.2	1.1	1.3
> +40 °C to +60 °C	1.4	1.3	1.5
> +60 °C to +80 °C	1.7	1.5	1.8
> +80 °C to +100 °C	2.0	1.8	2.1
> +100 °C to +120 °C	-	2.4	-

Cycle of starts factor S_z

Z_n (Cycle of starts [1/h])	up to 120	120 – 240	above 240
S_z	1.0	1.3	on request

$$T_{KN} > T_{2n} \times S_{\theta}$$

$$T_{KMax} > T_{2b} \times S_{\theta} \times S_z$$

T_{KN} = Rated torque of the coupling [Nm]

T_{KMax} = Max. torque of the coupling [Nm]

T_{2n} = Rated torque of the application [Nm]

T_{2b} = Max. acceleration torque of the application [Nm]

S_{θ} = Temperature factor

S_z = Cycle of start factor

The **alphabet**

Acceleration torque (T_{2B})

The acceleration torque T_{2B} is the maximum permissible torque that can briefly be transmitted at the output by the gearhead after $\leq 1000/h$ cycles. For $> 1000/h$ cycles, the **→ impact factor** must be taken into account. T_{2B} is the limiting parameter in cyclic operation.

Adapter plate

WITTENSTEIN alpha uses a system of standardized adapter plates to connect the motor and the gearhead, making it possible to mount an WITTENSTEIN alpha gearhead to any desired motor without difficulty.

Angular minute

A degree is subdivided into 60 angular minutes (= 60 arcmin = 60'). In other words, if the torsional backlash is specified as 1 arcmin, for example, the output can be turned $1/60^\circ$. The repercussions for the actual application are determined by the arc length: $b = 2 \cdot \pi \cdot r \cdot \alpha^\circ / 360^\circ$. A pinion with a radius $r = 50$ mm on a gearhead with standard torsional backlash $j_1 = 3'$ can be turned $b = 0.04$ mm.

Axial force (F_{2AMax})

In the case of SP+/LP+/SPK+, the axial force F_{2AMax} acting on a gearhead runs parallel to its output shaft. On a TP+, the force runs perpendicular to its output shaft. It may be applied with axial offset via a lever arm y_2 under certain circumstances, in which case it also generates a bending moment. If the axial force exceeds the permissible catalogue values, additional design features (e.g. axial bearings) must be implemented to absorb these forces.

Example with output shaft and flange:

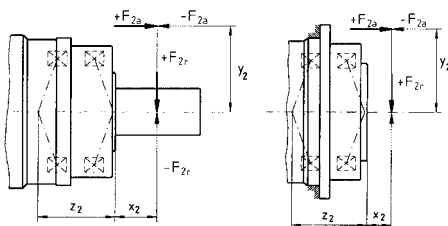

Bushing

If the motor shaft diameter is smaller than the **→ clamping hub**, a bushing is used to compensate the difference in diameter.

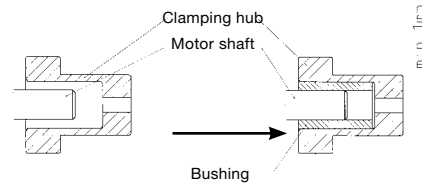

Clamping hub

The clamping hub ensures a frictional connection between the motor shaft and gearhead. A **→ bushing** is used as the connecting element if the motor shaft diameter is smaller than that of the clamping hub.

Continuous operation (S1)

Continuous operation is defined by the **→ duty cycle**. If the duty cycle is greater than 60 % or longer than 20 minutes, this qualifies as continuous operation. **→ Operating modes**

Cyclic operation (S5)

Cyclic operation is defined via the **→ duty cycle**. If the duty cycle is less than 60 % and shorter than 20 minutes, it qualified as cyclic operation (**→ operating modes**).

cymex®

cymex® is the calculation software developed by our company for dimensioning complete drive trains. We can also provide training to enable you to make full use of all the possibilities provided by the software.

Degree of protection (IP)

The various degrees of protection are defined in DIN EN 60529 "Degrees of protection offered by enclosure (IP code)". The IP degree of protection (IP stands for International Protection) is represented by two digits. The first digit indicates the protection against the ingress of

impurities and the second the protection against the ingress of water.

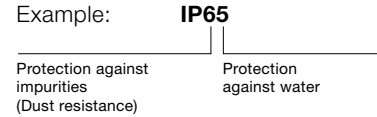

Duty cycle (ED)

The duty cycle ED is determined by one cycle. The times for acceleration (t_b), constant travel if applicable (t_c) and deceleration (t_d) combined yield the duty cycle in minutes. The duty cycle is expressed as a percentage with inclusion of the pause time t_e .

$$ED [\%] = \frac{t_b + t_c + t_d}{t_b + t_c + t_d + t_e} \cdot 100 \frac{\text{Motion duration}}{\text{Cycle duration}}$$

$$ED [\text{min}] = t_b + t_c + t_d$$

Efficiency (η)

Efficiency [%] η is the ratio of output power to input power. Power lost through friction reduces efficiency to less than 1 or 100 %.

$$\eta = P_{\text{out}} / P_{\text{in}} = (P_{\text{in}} - P_{\text{lost}}) / P_{\text{in}}$$

WITTENSTEIN alpha always measures the efficiency of a gearhead during operation at full load (T_{2B}). If the input power or torque are lower, the efficiency rating is also lower due to the constant no-load torque. Power losses do not increase as a result. Speed also has an effect on efficiency, as shown in the example diagram above.

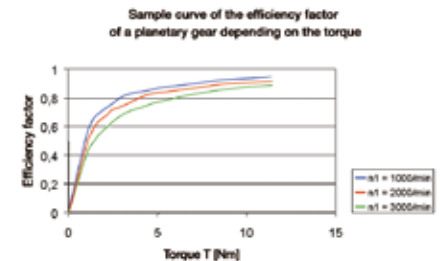

Emergency stop torque (T_{2Not})

The emergency stop torque [Nm] T_{2Not} is the maximum permissible torque at the gearhead output and must not be reached more than 1000 times during the life of the gearhead. It must never be exceeded!

→ Refer to this term for further details.

Ex symbol



Devices bearing the Ex symbol comply with EU Directive 94/9/EC (ATEX) and are approved for use in defined explosion-hazardous zones

Detailed information on explosion groups and categories, as well as further information on the relevant gearhead are available upon request.

HIGH SPEED® (MC)

The HIGH SPEED® version of our SP+ gearhead has been specially developed for applications in continuous operation at high input speeds, e.g. as found in the printing and packaging industries.

HIGH TORQUE® (MA)

The HIGH TORQUE® version of our TP+ gearhead has been specially developed for applications requiring extremely high torques and maximum rigidity.

MA = HIGH TORQUE®

MC = HIGH SPEED®

MF = standard versions of our WITTENSTEIN alpha servo gearheads

Hysteresis curve

The hysteresis is measured to determine the torsional rigidity of a gearhead. The result of this measurement is known as the hysteresis curve.

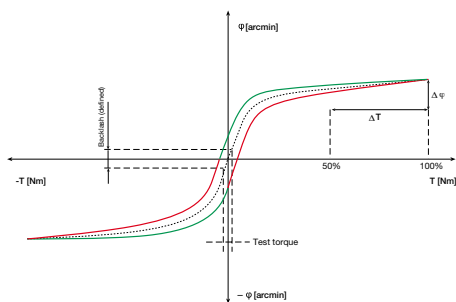

If the input shaft is locked, the gearhead is loaded with a torque that increases continuously up to T_{2B} and is then relieved at the output in both directions. The torsional angle is plotted against the torque. This yields a closed curve from which the \rightarrow **torsional backlash** and \rightarrow **torsional rigidity** can be calculated.

Impact factor (f_s)

The maximum permissible acceleration torque during cyclic operation specified in the catalog applies for a cycle rate less than 1000/h. Higher cycle rates combined with short acceleration times can cause vibrations in the drive train. Use the load factor f_s to include the resulting excess torque values in calculations.

The impact factor f_s can be determined with reference to the curve. This calculated value is multiplied by the actual acceleration torque T_{2b} and then compared with the maximum permissible acceleration torque T_{2B} . ($T_{2b} \cdot f_s = T_{2b,fs} < T_{2B}$)

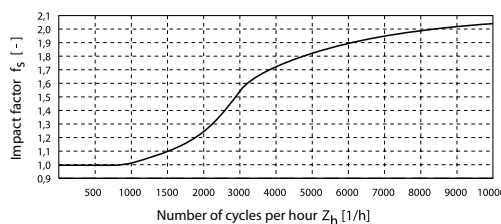

Jerk

Jerk is derived from acceleration and is defined as the change in acceleration within a unit of time. The term impact is used if the acceleration curve changes abruptly and the jerk is infinitely large.

Lateral force (F_R)

Lateral force is the force component acting at right angles to the output shaft with the SP+/LP+/SPK+ or parallel to the output flange with the TP+. It acts perpendicular to the axial force and can assume an axial distance of x_2 in relation to the shaft nut with the SP+/LP+ or shaft flange with the TP+, which acts as a lever arm. The lateral force produces a bending moment (see also axial force).

Mass moment of inertia (J)

The mass moment of inertia J is a measurement of the effort applied by an object to maintain its momentary condition (at rest or moving).

Mesh frequency (f_z)

The mesh frequency may cause problems regarding vibrations in an application, especially if the excitation frequency corresponds to the intrinsic frequency of the application. The mesh frequency can be calculated for all SP+, TP+, LP+ and alphira® gearheads using the formula $f_z = 1,8 \cdot n_2$ [rpm] and is therefore independent of the ratio if the output speed is the same. If it does indeed become problematic, the intrinsic frequency of the system can be changed or another gearhead (e.g. hypoid gearhead) with a different mesh frequency can be selected.

NSF symbol



Lubricants certified as grade H1 by the NSF (NSF = National Sanitation Foundation) can be used in the food sector where occasional unavoidable contact with food cannot be excluded.

No load running torque (T_{012})

The no load running torque T_{012} is the torque which must be applied to a gearhead in order to overcome the internal friction; it is therefore considered lost torque. The values specified in the catalog are calculated by WITTENSTEIN alpha at a speed of $n_1 = 3000$ rpm and an ambient temperature of 20 °C.

T_{012} : 0 1 → 2
no load from input end
to output end

Nominal torque (T_{2N})

The nominal torque [Nm] T_{2N} is the torque continuously transmitted by a gearhead over a long period of time, i.e. in → **continuous operation** (without wear).

Operating modes (continuous operation **S1** and cyclic operation **S5**)

When selecting a gearhead, it is important to consider whether the motion profile is characterized by frequent acceleration and deceleration phases in cyclic operation (S5) as well as pauses, or whether it is

designed for continuous operation (S1), i.e. with long phases of constant motion.

Operating noise (L_{PA})

Low noise level L_{PA} is a factor of growing importance for environmental and health reasons. WITTENSTEIN alpha has succeeded in reducing the noise of the new SP+ gearheads by another 6 dB(A) over the former SP units (i.e. sound reduced to one quarter). Noise levels are now currently 64 - 70 dB(A) depending on the size of the gearhead.

The gear ratio and speed both affect the noise level. The relationships are demonstrated in the following trend graphs.

As a general rule: A higher speed means a higher noise level, while a higher ratio means a lower noise level. The values specified in our catalog relate to gearheads with the ratio $i = 10/100$ at a speed of $n = 3000$ rpm.

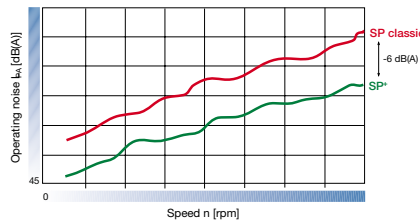

Change in operating noise in relation to the ratio

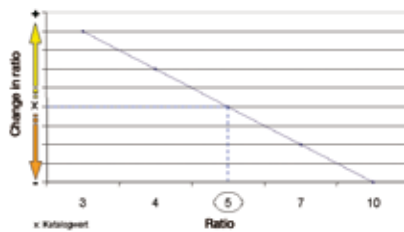

Positioning accuracy

The positioning accuracy is determined by the angular deviation from a setpoint and equals the sum of the torsional angles due to load → **(torsional rigidity and torsional backlash)** and kinetics → **(synchronization error)** occurring simultaneously in practise.

Rate of mass moment of inertia ($\lambda = \text{Lambda}$)

The ratio of mass moment of inertia λ is the ratio of external inertia (application side) to internal inertia (motor and gearhead side). It is an important parameter determining the controllability of an application. Accurate control of dynamic processes becomes more difficult with differing mass moments of inertia and as λ becomes greater. WITTENSTEIN alpha recommends that a guideline value of $\lambda < 5$ is maintained. A gearhead reduces the external mass moment of inertia by a factor of $1/i^2$.

$$\lambda = \frac{J_{\text{external}}}{J_{\text{internal}}}$$

J_{external} reduced to the gear input:
 $J'_{\text{external}} = J_{\text{external}} / i^2$

Simple applications ≤ 10
Dynamic applications ≤ 5
Highlydynamic applications ≤ 1

Ratio (i)

The gear ratio i indicates the factor by which the gearhead transforms the three relevant parameters of motion (speed, torque and mass moment of inertia). The factor is a result of the geometry of the gearing elements (Example: $i = 10$).

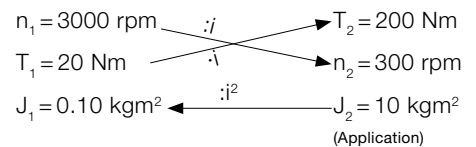

Speed (n)

Two speeds are of relevance when dimensioning a gearhead: the maximum speed and the nominal speed at the input. The maximum permissible speed n_{1Max} must not be exceeded because it serves as the basis for dimensioning → **cyclic operation**. The nominal speed n_{1N} must not be exceeded in → **continuous operation**.

The housing temperature limits the nominal speed, which must not exceed 90 °C. The nominal input speed specified in the catalogue applies to an ambient temperature of 20 °C. As can be seen in the diagram below, the temperature limit is reached more quickly in the presence of an elevated outside temperature. In other words, the nominal input speed must be reduced if the ambient temperature is high. The values applicable to your gearhead are available from WITTENSTEIN alpha on request.

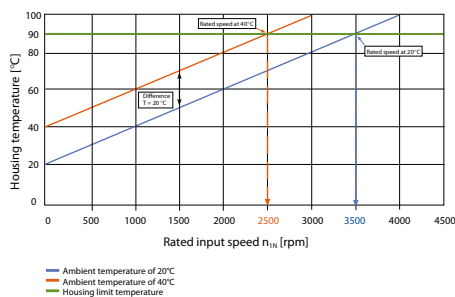

Synchronization error

The synchronization error is equal to the variations in speed measured between the input and output during one revolution of the output shaft. The error is caused by manufacturing tolerances and results in minute angular deviations and fluctuations in ratio.

T_{2Max}

T_{2Max} means the maximum torque which can be transmitted by the gearbox.

This value can be chosen for applications that can accept a slight increase in backlash over time.

T_{2Servo}

T_{2Servo} is a special value for precision applications in which a minimum backlash must be guaranteed over the life of the gearbox. The increase in backlash seen in other worm gears is less due to the optimized hollow flank teeth.

Technical data

The technical data relating to our products can be downloaded from our homepage. Alternatively, you can send your requests, suggestions and comments to the address below.

Tilting moment (M_{2K})

The tilting torque M_{2K} is a result of the → **axial and lateral forces** applied and their respective points of application in relation to the inner radial bearing on the output side.

Timing belt

The AT profile of the Wittenstein standard belt pulley is a flank-centered profile for backlash-free torque transmission.

Effective diameter

$d_0 = \text{Number of teeth } z \times \text{Pitch } p / \text{Pi}$

Recommended preload per strand for linear drives $F_v \geq F_u$

Radial force at the output shaft for the determination of the bearing life:

$$F_r = 2 \times F_v$$

Torque (M)

The torque is the actual driving force of a rotary motion. It is the product of lever arm and force. $M = F \cdot l$

Torsional backlash (j_t)

Torsional backlash j_t is the maximum angle of torsion of the output shaft in relation to the input. Torsional backlash is measured with the input shaft locked.

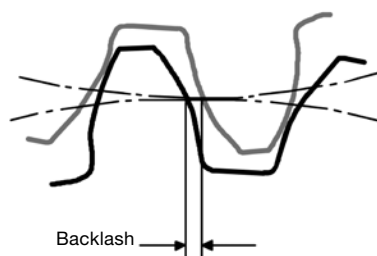

The output is then loaded with a defined test torque in order to overcome the internal gearhead friction. The main factor affecting torsional backlash is the face

→ Refer to this term for further details.

clearance between the gear teeth. The low torsional backlash of WITTENSTEIN alpha gearheads is due to their high manufacturing accuracy and the specific combination of gear wheels.

Torsional rigidity (C_{t21})

Torsional rigidity [Nm/arcmin] C_{t21} is defined as the quotient of applied torque and generated torsion angle ($C_{t21} = \Delta T / \Delta \phi$). It consequently shows the torque required to turn the output shaft by one angular minute. The torsional rigidity can be determined from the → **hysteresis curve**. Only the area between 50% and 100% of T_{2B} is considered for because this area of the curve profile can be considered linear.

Torsional rigidity C , Torsion angle ϕ

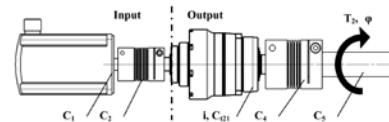

Reduce all torsional rigidities to the output:

$$C_{(n),output} = C_{(n),input} \cdot i^2$$

with $i = \text{Gear ratio [-]}$

$C_{(n)}$ = single stiffness [Nm/arcmin]

Note: the torsional rigidity C_{t21} of the gearbox always relates to the output.

Series connection of torsional rigidities

$$1/C_{ges} = 1/C_{1,output} + 1/C_{2,output} + \dots + 1/C_{(n)}$$

Torsion angle ϕ [arcmin]

$$\phi = T_2 \cdot 1/C_{ges}$$

with $T_2 = \text{Output torque [Nm]}$

WITTENSTEIN alpha speedline®

If required, we can deliver a new SP+, TP+ or LP+ within 24 or 48 hours ex works.

Formulae

Torque [Nm]	$T = J \cdot \alpha$	J = Mass moment of inertia [kgm ²] $\alpha = An$ [1/s ²]
Torque [Nm]	$T = F \cdot l$	F = Force [N] l = Lever, length [m]
Acceleration force [N]	$F_b = m \cdot a$	m = Mass [kg] a = Linear acceleration [m/s ²]
Frictional force [N]	$F_{frict} = m \cdot g \cdot \mu$	g = Acceleration due to gravity 9.81 m/s ² μ = Coefficient of friction
Angular velocity [1/s]	$\omega = 2 \cdot \pi \cdot n / 60$	n = Speed [rpm] π = PI = 3.14...
Linear velocity [m/s]	$v = \omega \cdot r$	v = Linear velocity [m/s] r = Radius [m]
Linear velocity [m/s] (spindle)	$v_{sp} = \omega \cdot h / (2 \cdot \pi)$	h = Screw pitch [m]
Linear acceleration [m/s ²]	$a = v / t_b$	t_b = Acceleration time [s]
Angular acceleration [1/s ²]	$\alpha = \omega / t_b$	
Pinion path [mm]	$s = m_n \cdot z \cdot \pi / \cos \beta$	m_n = Standard module [mm] z = Number of teeth [-] β = Inclination angle [°]

Conversion table

1 mm	= 0.039 in
1 Nm	= 8.85 in lb
1 kgcm ²	= 8.85 x 10 ⁻⁴ in.lb.s ²
1 N	= 0.225 lb _f
1 kg	= 2.21 lb _m

Symbols

Symbol	Unit	Designation
C	Nm/arcmin	Rigidity
ED	%, min	Duty cycle
F	N	Force
f_s	–	Load factor
f_t	–	Temperature factor
f_e	–	Factor for duty cycle
i	–	Ratio
j	arcmin	Backlash
J	kgm ²	Moment of inertia
K1	Nm	Factor for bearing calculation
L	h	Service life
L_{PA}	dB(A)	Operating noise
m	kg	Mass
M	Nm	Torque
n	rpm	Speed
p	–	Exponent for bearing calculation
η	%	Efficiency
t	s	Time
T	Nm	Torque
v	m/min	Linear velocity
x	mm	Distance between lateral force and shaft collar
y	mm	Distance between axial force and center of gearhead
z	mm	Factor for bearing calculation
Z	1/h	Number of cycles

Index

Capital letter	Permissible values
Small letter	Actual values
1	Drive
2	Output
A/a	Axial
B/b	Acceleration
c	Constant
cym	cymex® values (load-related characteristic values)
d	Deceleration
e	Pause
h	Hours
K/k	Tilting
m	Mean
Max/max	Maximum
Mot	Motor
N	Nominal
Not/not	Emergency stop
0	No load
R/r	Radial
t	Torsional
T	Tangential

Order information

Gearhead type TP+ 004 – TP+ 500 SP+ 060 – SP+ 240 TK+ 004 – TK+ 110 TPK+ 010 – TPK+ 500 SK+ 060 – SK+ 180 SPK+ 075 – SPK+ 240 HG+ 060 – HG+ 180	Type code S = Standard F = Food lubrication G = Grease W = Washdown (SP+, TP+, SK+, SPK+, TK+, TPK+, HG+) B = Modular output combination (SK+, SPK+, TK+, TPK+, HG+) L = Low Friction (SP+100-180 HIGH SPEED)	Gearhead variations M = Motor attachment gearhead	Gearhead model A = HIGH TORQUE® (only TP+/TPK+) C = HIGH SPEED® (only SP+) F = Standard	Number of stages 1 = 1-stage 2 = 2-stage 3 = 3-stage
---	---	---	---	--

* Order shrink discs separately, see section accessories, shrink discs on page 342

Gearhead type LP 050 – LP 155 LPB 070 – LPB 120 LK 050 – LK 155 LPK 050 – LPK 155 LPBK 070 – LPBK 120 CP 040 – CP 115	Gearhead variations M = Motor attachment gearhead	Gearhead model O = Standard L = Food-grade grease	Number of stages 1 = 1-stage 2 = 2-stage 3 = 3-stage (LPK+)	Ratios See technical data sheets.
--	---	--	---	---

Gearhead type VDT = TP flange VDH = hollow shaft VDS = shaft	Gearhead version e = economy (only for VDH and VDS, size 050 and 063)	Distance between axes 050 063 080 100	Gearhead variations M = Motor attachment gearhead	Gearhead model F = Standard L = Food-grade grease W = Washdown	Number of stages 1 = 1-stage
--	---	--	---	--	--

** See section accessories, shrink discs on page 326

Mounting positions for V-Drive®

Mounting position (only relevant for oil volume)

Output side A:
View of motor interface
Only valid for VDS+, VDS_e and VDT+

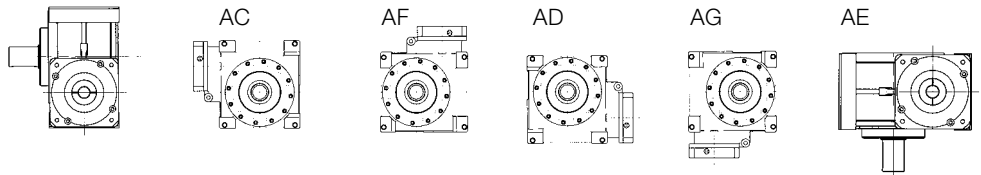

Output side B:
View of motor interface
Only valid for VDS+, VDS_e und VDT+

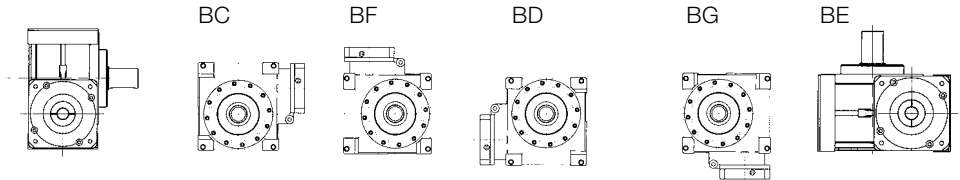

For VDH+, VDHe and VDS+/VDS_e with Dual-shaft output, A and B must be replaced with 0 (zero).

Ratios

See technical data sheets.

Output shape

0 = smooth shaft/flange
(no hollow shaft)
 1 = shaft with key
 2 = involute to DIN 5480
 3 = system output
 4 = other
 5* = Hollow shaft interface /
 Flanged hollow shaft (TK*)
 Shaft mounted (SP*)
 6* = 2 hollow shaft inter-
 faces (HG*)
 (see technical data sheets)

Clamping hub bore hole diameter

(see technical data sheets and clamping hub diameter table)

Backlash

1 = Standard
 0 = Reduced
 (see technical data sheets)

x = Special model

Output shape

0 = smooth shaft (for LP+ and LPK+ models only; for LP+ smooth shaft available with reduced torsional backlash only)
 1 = shaft with key
LPB+
 1 = centering on output side
 3 = centering on motor side
 (see technical data sheets)

Clamping hub bore hole diameter

1 = Standard
 2 = Large clamping hub
 (only LP und LPB)
 (see technical data sheets)

Backlash

1 = Standard
 (not LP+ with smooth shaft)
 0 = Reduced
 (LP+/LPB+ only)

x = Special model

Ratios

4 (not for economy)
 7
 10
 16
 28
 40

Output shape

0 = smooth shaft/flange
 (VDT+, VDH+, VDS+, VDHe, VDSe)
 1 = shaft with key
 (VDH+, VDS+, VDHe, VDSe)
 2 = involute to DIN 5480
 (VDS+)
 4 = other
 (see technical data sheets)
 8 = Dual-shaft output,
 smooth (VDS+, VDSe)
 9 = Dual-shaft output
 with key (VDS+, VDSe)

Clamping hub bore hole diameter

3 = 19 mm (050)
 4 = 28 mm (063)
 5 = 35 mm (080)
 7 = 48 mm (100)

Backlash

1 = Standard

VDH – number of shrink discs**

0 = no shrink disc
 1 = one shrink disc
 2 = two shrink discs

x = Special model

Mounting positions for right-angle gearheads

For information purposes only – not required when placing orders!

Permitted standard mounting positions for right-angle gearheads (see illustrations)

If the mounting position is different, contact WITTENSTEIN alpha

B5/V3
 Output shaft, horizontal
 Motor shaft upwards



B5/V1
 Output shaft, horizontal
 Motor shaft downwards



V1/B5
 Output shaft, vertical
 Motor shaft, horizontal

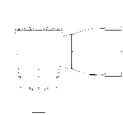

V3/B5
 Output shaft, vertical, upwards
 Motor shaft, horizontal

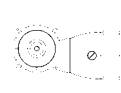

B5/B5
 Output shaft, horizontal
 Motor shaft, horizontal

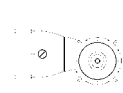

Order codes

TP⁺/SP⁺/TK⁺/TPK⁺/SK⁺/SPK⁺/HG⁺

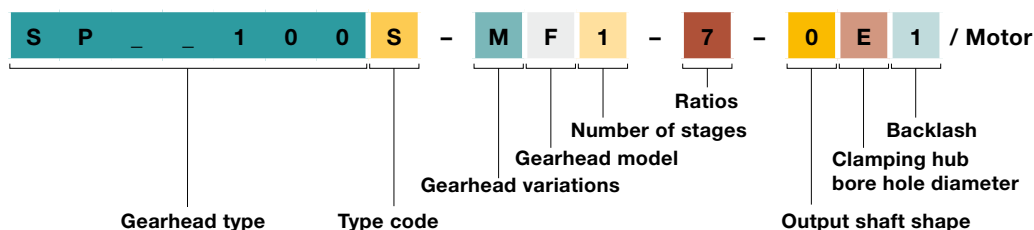

LP⁺/LPB⁺/LK⁺/LPK⁺/alphira[®] (CP)

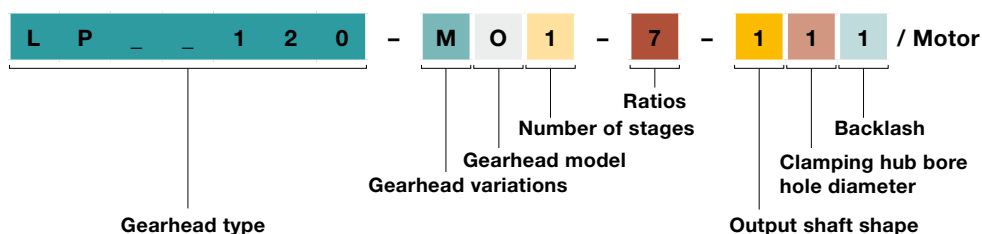

V-Drive[®]

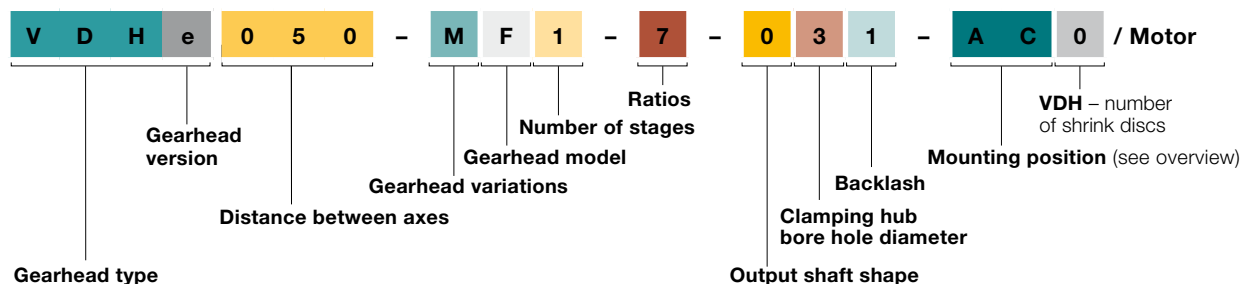

Mounting positions for coaxial gearheads

For information purposes only not required when placing orders!

B5 – horizontal

V1 – vertical
Output shaft downwards

V3 – vertical
Output shaft upwards

S – can be tilted
±90° from a horizontal position

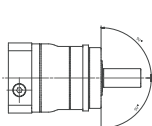
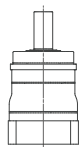
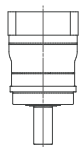
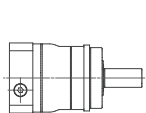

Clamping hub diameter

(the technical data sheet contains all diameters available for TP⁺, SP⁺, TK⁺, TPK⁺, SK⁺, SPK⁺ and HG⁺ models)

Code letter	mm	Code letter	mm
B	11	I	32
C	14	K	38
D	16	L	42
E	19	M	48
G	24	N	55
H	28	O	60

Intermediate diameters possible in combination with a bushing with a minimum thickness of 1 mm.

Order codes



Order information

Rack and assembly jig

Rack type ZST = Rack ZMT = Assembly jig	Module 200 = 2.00 300 = 3.00 400 = 4.00 500 = 5.00 600 = 6.00	Version PA5 = Premium Class SB6 = Smart Class VB6 = Value Class PD5 = Assembly jig	Length 100 = Assembly jig (module 2–3) 156 = Assembly jig (module 4–6) 480 = Smart Class (module 2–4) 167/333 = Premium Class (module 2) 250 = Premium Class (module 3) 500 = Premium Class (module 2–6) 1000 = Value Class (module 2–6)
--	---	---	--

Premium Class⁺ and Value Class pinion

Designation RMT = Pinion mounted ex works RMX = Pinion mounted offset 180° (for VC pinions only)	Module 200 = 2.00 300 = 3.00 400 = 4.00 500 = 5.00 600 = 6.00	Version PC5 = Premium Class VC6 = Value Class	Number of teeth (see technical data sheet)
---	---	--	--

Premium Class RTP and Standard Class RSP pinions

Designation RSP = Standard Class RSP pinion for SP involute output as per DIN 5480 RTP = Premium Class RTP pinion for TP output RTPA = Premium Class RTP pinion for TP High Torque output	Gearhead size For SP output: 060, 075, 100, 140, 180, 210, 240 For TP output: 004, 010, 025, 050, 110, 300, 500 (see technical data sheets)	Module A02 = 2.00 A03 = 3.00 A04 = 4.00 A05 = 5.00 A06 = 6.00	Tolerance class 5e24 = Premium Class RTP/RTPA 6e25 = Standard Class RSP	Number of teeth (see technical data sheet)
---	---	---	--	--

Torque limiter, bellows and elastomer coupling

Model Torque limiter TL1 / TL2 / TL3 Bellows coupling BC2 / BC3 / BCT / EC2 Elastomer couplings ELC / EL6	Series – Nominal torque (see technical data sheets)	Length options A = first series B = second series only for TL2 / TL3 / BC2 / BC3 and EC Elastomer couplings A = 98 Sh A B = 64 Sh A C = 80 Sh A	Version Torque limiter W = Single position re-engagement (standard version) D = Multi-position G = Load holding F = Full disengagement X = Special Bellows/Elastomer coupling A = Standard Elastomer couplings X = Sonder	Internal diameter D_1^{H7} TL1: $D = D_1 = D_2$ (for miniature version, 1.5 – 10 Nm)
Internal diameter version D_1 0 = smooth shaft 1 = with key to DIN 6885 Shape A 2 = Involute to DIN 5480 4 = Other (specific for key) 5 = Key connection (TL1 only, type C)	Internal diameter D_2^{H7} Hole circle diameter D_3 (BCT) TL1: $D = D_1 = D_2$ (for miniature version, 1.5 – 10 Nm)	Internal diameter version D_2 0 = smooth shaft 1 = with key to DIN 6885 Shape A 2 = Involute to DIN 5480 4 = Other (specific for key) 5 = Key connection (TL1 only, type C)	Adjustment range (only for TL1 / TL2 / TL3) A = first series B = second series C = third series	Disengagement torque (only for TL1 / TL2 / TL3)

Order codes

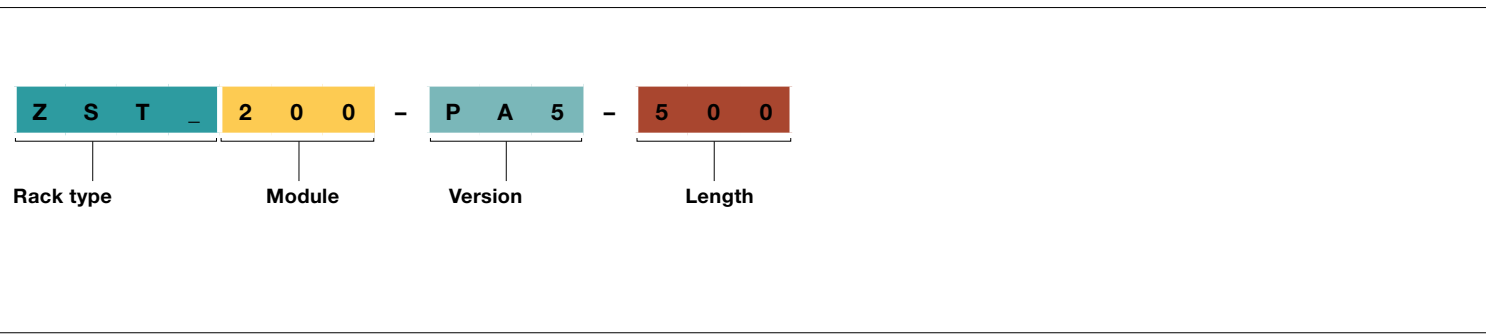

Premium Class⁺ and Value Class pinion

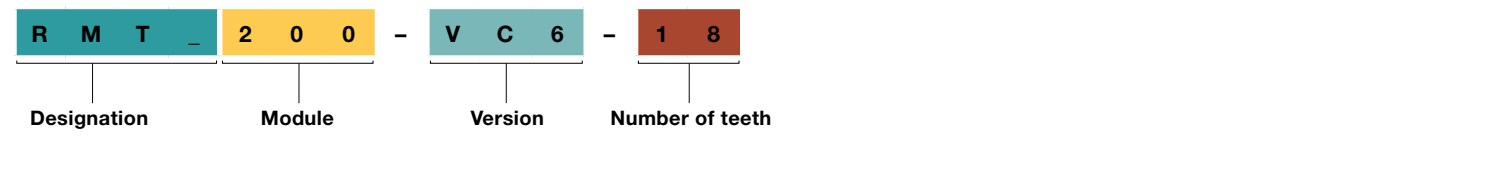

Premium Class RTP and Standard Class RSP pinions

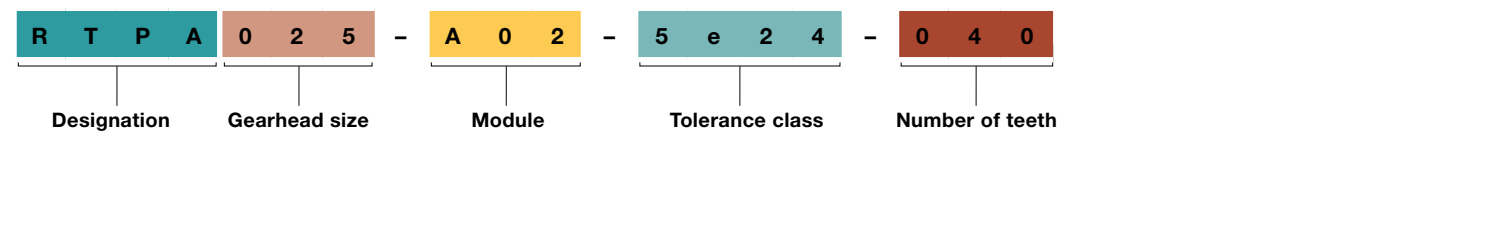

Torque limiter

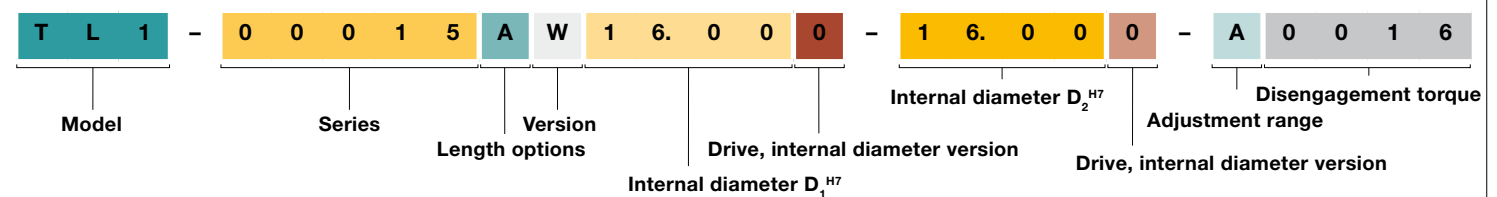

Bellows couplings

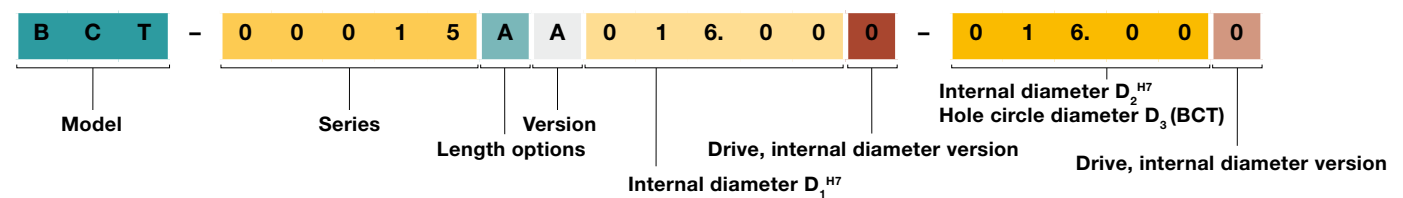

Elastomer couplings

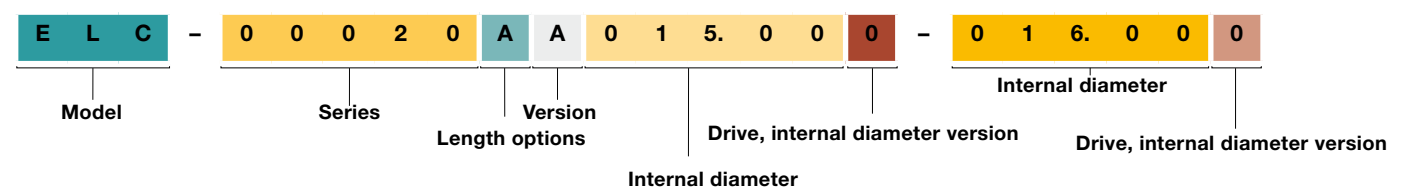

YOUR NOTE

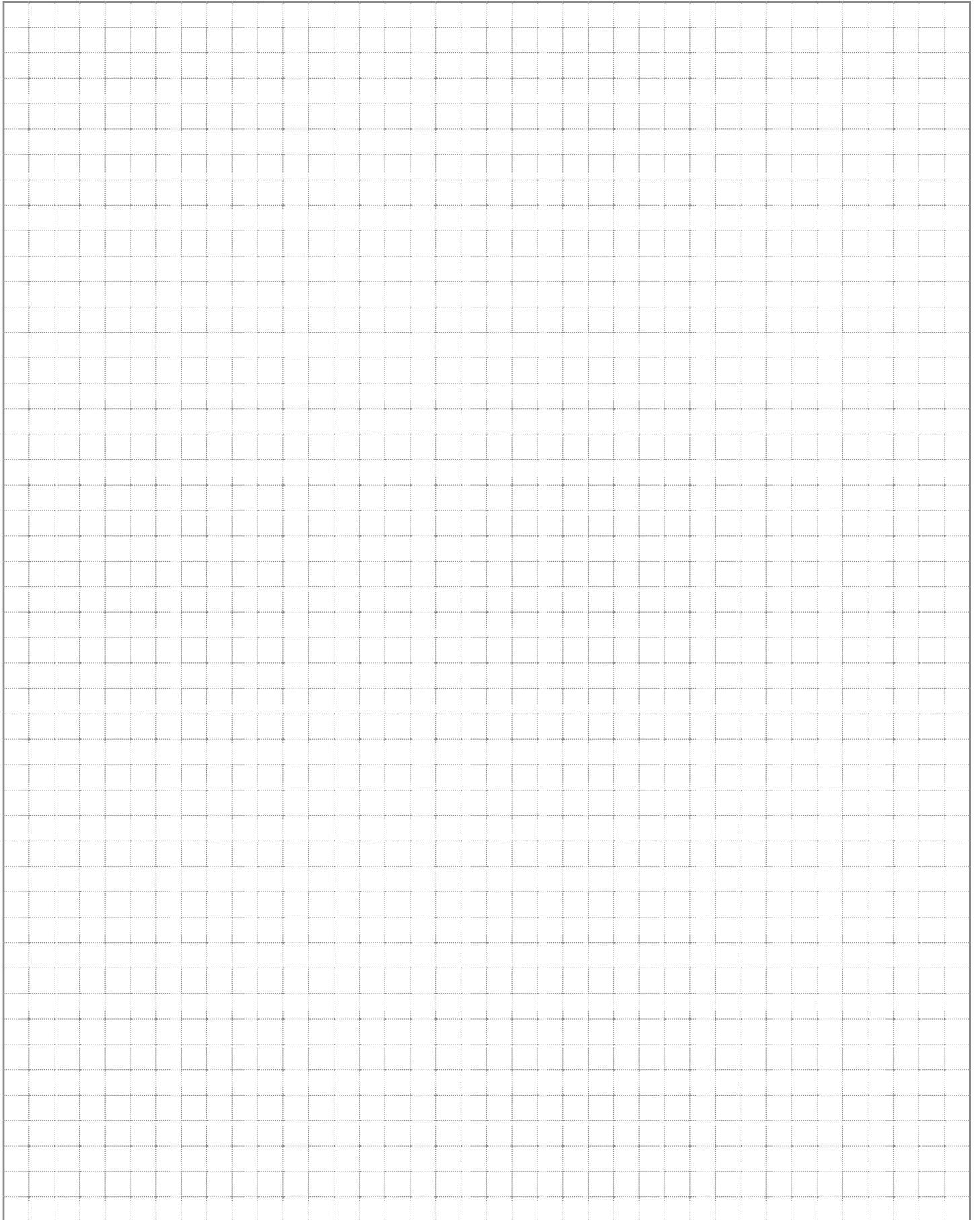

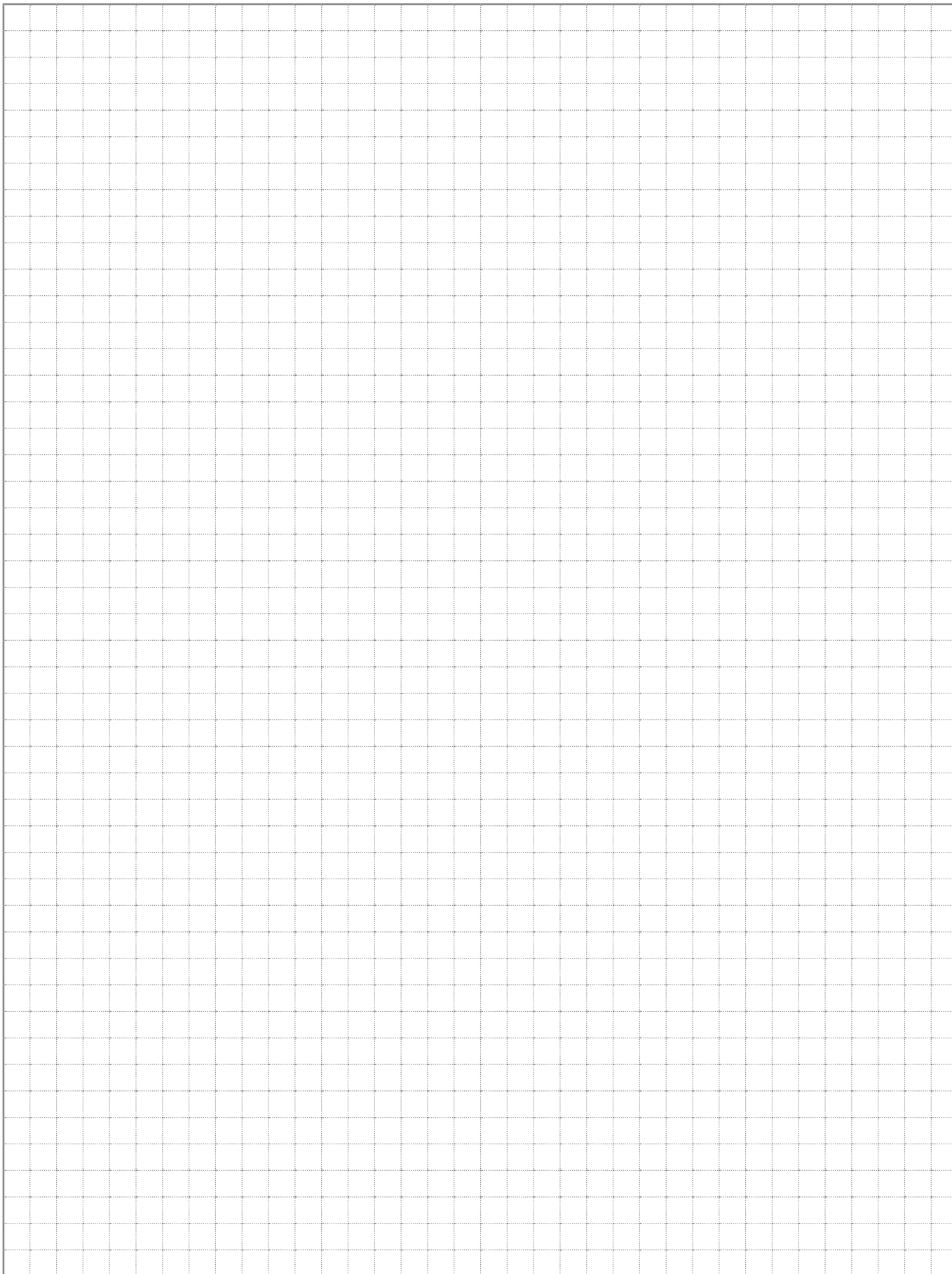

YOUR NOTE

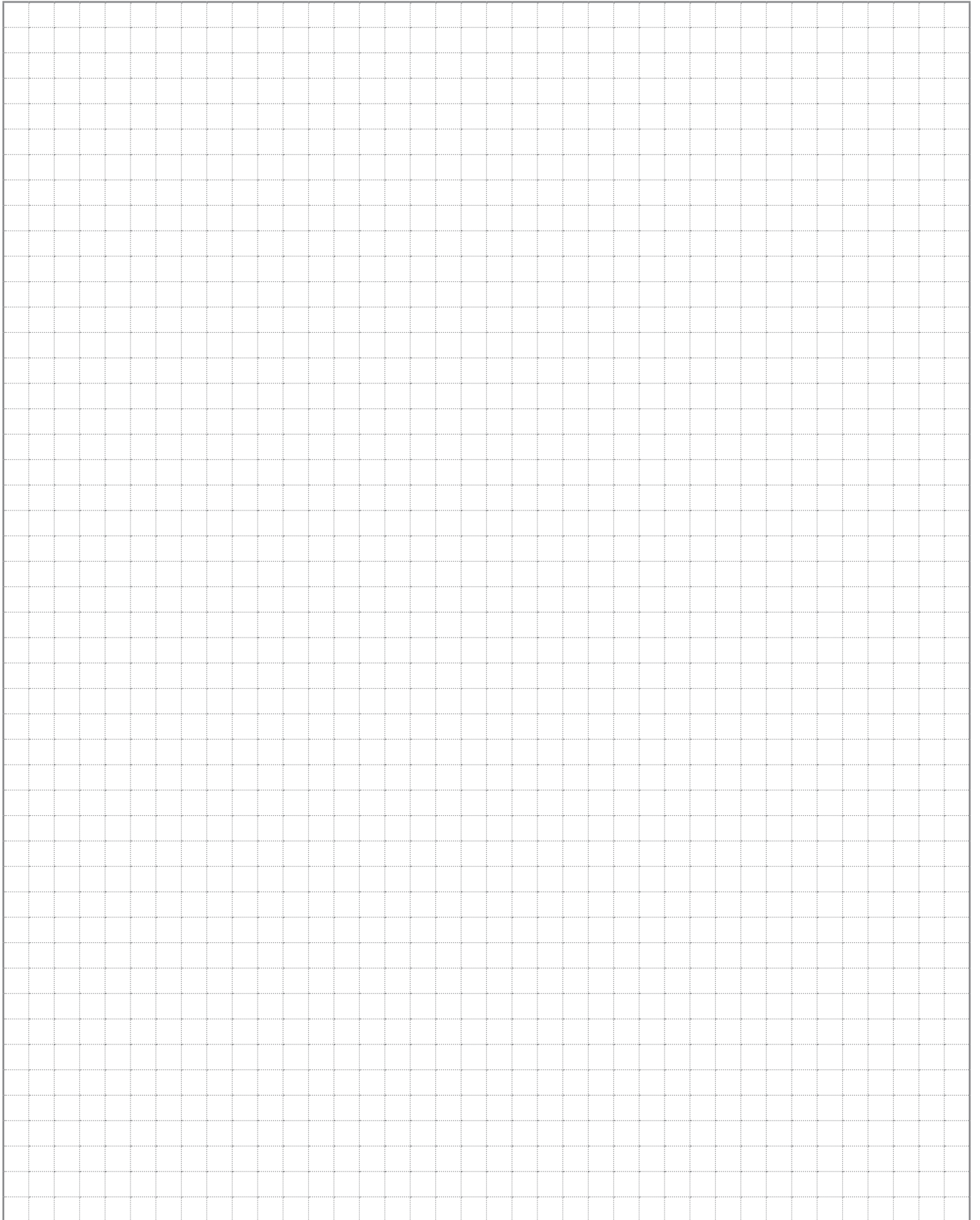

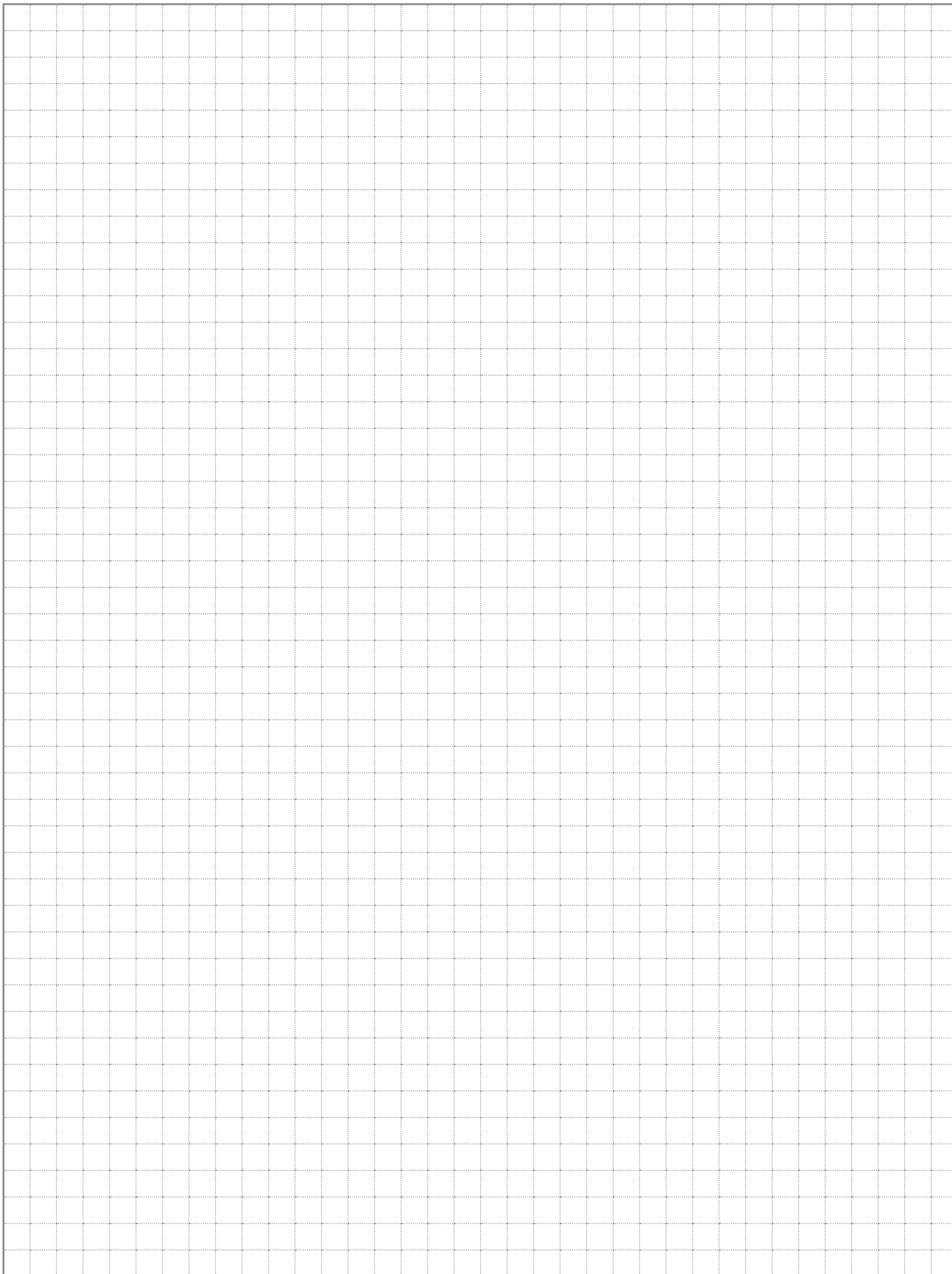



alpha

WITTENSTEIN alpha GmbH
Walter-Wittenstein-Straße 1
97999 Igersheim
Germany

Switchboard: Tel. +49 7931 493-0
24h-Hotline: Tel. +49 7931 493-10900
speedline: Tel. +49 7931 493-10333 or 10444

www.wittenstein-alpha.de

